



Emotron VSU

AC Drive

0.4kW to 15kW / 0.5Hp to 20Hp



Instruction manual

English

Thank you for choosing Emotron VSU Series General Purpose AC Motor Drives from CG Drives & Automation. This user manual presents a detailed description of Emotron VSU series with respect to product features, structural characteristics, functions, installation, parameter setting, troubleshooting, commissioning and daily maintenance, etc. Be sure to carefully read through the safety precautions before use, and use this product on the premise that personnel and equipment safety is ensured.

IMPORTANT NOTES

- Ø Please assure the intactness of product enclosure and all safety covers before installation .Operation must conform to the requirements of this manual and local industrial safety regulations and/or electrical codes.
- Ø Contents of this manual may be subject to appropriate modification as a result of product upgrade, specification change and update of the manual.
- Ø In the event of damage or loss of user manual, users may ask local distributors, offices or our Technical Service Department for a new one.
- Ø If any item as stated in this manual is not clear, please contact our Technical Service Department.
- Ø If any anomaly occurs after power up or during the operation, it is essential to stop the machine and identify the fault or seek technical services as soon as possible.

Emotron VSU

Instruction manual - English

Software type/version: C6000/08.01.0060

Document number: 01-5479-01

Edition: r1

Date of release: 01-05-2014

© Copyright Crompton Greaves Ltd 2013 - 2014

Crompton Greaves Ltd retains the right to change specifications and illustrations in the text, without prior notification. The contents of this document may not be copied without the explicit permission of Crompton Greaves Ltd.

Contents

Chapter 1 Safety Precautions	- 1 -
1.1 Safety Considerations	- 1 -
1.2 Other Considerations	- 6 -
Chapter 2 Product Information	- 9 -
2.1 Model Explanation	- 9 -
2.5 Parts Drawing	- 14 -
2.6 Appearance, Mounting Dimensions and Weight	- 14 -
2.7 External Dimensions of Keypad	- 16 -
2.8 External Dimensions of Keypad Bracket	- 16 -
Chapter 3 Installation and Wiring	- 17 -
3.1 Installation Environment	- 17 -
3.2 Minimum Mounting Clearances	- 17 -
3.3 Remove & Mount Keypad and Cover	- 18 -
3.4 Configuration of Peripheral Devices	- 21 -
3.5 Terminal Configuration	- 26 -
3.6 Main Circuit Terminals and Wiring	- 27 -
3.7 Control Terminal Wiring	- 33 -
3.8 Control Terminal Specification	- 37 -
3.9 Control Terminal Usage	- 38 -
3.10 Instruction of Signal Switches	- 44 -
Chapter 4 Operation and Run Instructions	- 44 -
4.1 Operation of Keypad	- 44 -
4.2 Initial Power up	- 62 -
Chapter 5 List of Parameters	- 72 -
Chapter 6 Specification of Parameters	- 114 -
Group A System Parameter and Parameter Management	- 114 -
Group b Setting of Running Parameters	- 119 -
Group C Input and Output Terminals	- 145 -
Group d Motor and Control Parameters	- 178 -

Group E Enhancement Function and Protection Parameters	- 197 -
Group F Application	- 205 -
Group H Communication Parameters	- 227 -
Group L Keys and Display of Keypad	- 229 -
Group U Monitoring	- 233 -
Chapter 7 Troubleshooting	- 240 -
7.1 Fault Causes and Troubleshooting	- 240 -
Chapter 8 Maintenance	- 248 -
8.1 Routine Inspection	- 248 -
8.2 Regular Maintenance	- 249 -
8.3 Replacement of Vulnerable Parts	- 250 -
8.4 Storage	- 251 -
Chapter 9. Options	- 253 -
Appendix Communication Protocol	- 254 -
1. Networking Mode	- 254 -
2. Interface Mode	- 254 -
3. Communication Mode	- 254 -
4. Protocol Format	- 255 -
5. Protocol Function	- 257 -
6. Operation Instructions	- 271 -
7. LRC/CRC Generation	- 275 -

Chapter 1 Safety Precautions

Safety Precautions

Safety signs in this manual:

 **WARNING:** indicates the situation in which the failure to follow operating requirements may result in fire or serious personal injury or even death.

 **ATTENTION:** indicates the situation in which the failure to follow operating requirements may cause moderate or slight injury and damage to equipment.

Users are requested to read this chapter carefully when installing, commissioning and repairing this product and perform the operation according to safety precautions as set forth in this chapter without fail. CG Drives & Automation will bear no responsibility for any injury and loss as a result of any violation operation.

1.1 Safety Considerations

1.1.1 Prior to Installation

 WARNING
<ul style="list-style-type: none">∅ Do not touch control terminals, circuit boards and any other electronic parts and components with bare hands.∅ Do not use the drive whose component(s) is/are missing or damaged. Failure to comply with may result in more faults and/or personal injury even death.

 ATTENTION
<ul style="list-style-type: none">∅ Check if the product information indicated on the nameplate is consistent with the order requirements. If not, do not install it.∅ Do not install the drive in the event that the packing list does not match with real equipment.

1.1.2 Installation



WARNING

- Ø Only qualified personnel familiar with adjustable frequency AC drives and associated machinery should plan or implement the installation. Failure to comply may result in equipment damage and/or personnel injury even death.
- Ø This equipment must be mounted on metal or other flame retardant objects. Failure to comply may result in fire.
- Ø This equipment must be mounted in an area which is away from combustibles and heat sources. Failure to comply may result in fire.
- Ø This equipment must in no case be mounted in the environment exposed to explosive gases. Failure to comply may result in explosion.
- Ø Never adjust mounting bolts of this equipment, especially the ones with red markers. Failure to comply may result in equipment damage.



ATTENTION

- Ø Handle the equipment gently and take hold of its sole plate so as to avoid foot injury or equipment damage.
- Ø Mount the equipment where its weight can be withstood. Failure to comply may result in equipment damage and/or personnel injury if falling happens.
- Ø Make sure the installation environment conforms to the requirements as stated in Section 2.4. If not, de-rating is necessary. Failure to comply may result in equipment damage.
- Ø Prevent drilling residues, wire ends and screws from falling into the equipment during installation. Failure to comply may result in faults or equipment damage.
- Ø When mounted in a cabinet, this equipment should be provided with appropriate heat dissipation. Failure to comply may result in faults or equipment damage.

1.1.3 Wiring

**WARNING**

- Ø Only qualified personnel familiar with adjustable frequency AC drives and associated machinery should plan or implement the wiring. Failure to comply may result in personnel injury and/or equipment damage.
- Ø Wiring must strictly conform to this manual. Failure to comply may result in personnel injury and/or equipment damage.
- Ø Make sure the input power supply has been completely disconnected before wiring. Failure to comply may result in personnel injury and/or equipment damage.
- Ø All wiring operations must comply with EMC and safety regulations and/or electrical codes, and the conductor diameter should conform to recommendations of this manual. Failure to comply may result in personnel injury and/or equipment damage.
- Ø Since overall leakage current of this equipment may be bigger than 3.5mA, for safety's sake, this equipment and its associated motor must be well grounded so as to avoid risk of electric shock.
- Ø Be sure to implement wiring in strict accordance with the marks on this equipment's terminals. Never connect three-phase power supply to output terminals U/T1, V/T2 and W/T3. Failure to comply may result in equipment damage.
- Ø Install braking resistors at terminals ⊕2/B1 and B2 only. Failure to comply may result in equipment damage.
- Ø Install DC reactor at terminals ⊕1 and ⊕2, and remove the jumper connected at ⊕1 and ⊕2. Never connect this jumper and DC reactor to any other terminals. Failure to comply may result in short circuit and equipment damage.
- Ø Wiring screws and bolts for main circuit terminals must be screwed tightly. Failure to comply may result in equipment damage.
- Ø AC 220V signal is prohibited from connecting to other terminals than control terminals RA, RB and RC. Failure to comply may result in equipment damage.

 **ATTENTION**

- Ø Since all adjustable frequency AC drives from CG Drives & Automation have been subjected to hi-pot test before delivery, users are prohibited from implementing such a test on this equipment. Failure to comply may result in equipment damage.
- Ø Signal wires should to the best of the possibility be away from main power lines. If this cannot be ensured, vertical cross-arrangement shall be implemented, otherwise interference noise to control signal may occur.
- Ø If motor cables are longer than 100m, it is recommended output AC reactor be used. Failure to comply may result in faults.
- Ø The coder must be provided with shielded cables whose shielded layer must be well grounded.

1.1.4 Running

 **WARNING**

- Ø Drives which have been stored for more than 2 years should be used with voltage regulator to gradually boost the voltage when applying power to the drives. Failure to comply may result in equipment damage.
- Ø Be sure to implement the wiring as per Section 3.4 before applying power to the drive. Failure to comply may result in equipment damage and/or electric shock hazard.
- Ø Be sure to confirm the completion and correctness of the drive wiring and close the cover before applying power to the drive. Do not open the cover after applying power. Failure to comply may result in electric shock hazard.
- Ø After applying the power, never touch the drive and peripheral circuits no matter what state the drive is under, otherwise there will be electric shock hazard.
- Ø Prior to the running of the drive, check there is no person in surrounding area who can reach the motor so as to prevent personal injury.
- Ø During the running of the drive, foreign bodies should be prevented dropping into the equipment. Failure to comply may result in faults and/or equipment damage.
- Ø Only qualified technicians familiar with adjustable frequency AC drives are allowed to perform signal test during operation. Failure to comply may result in equipment damage and/or personal injury.
- Ø Never change the drive parameters at will. Failure to comply may result in equipment damage.

 **ATTENTION**

- Ø Make sure the number of phases of power supply and rated voltage are consistent with product nameplate. If not, contact the seller or CG Drives & Automation.
- Ø Check there are no short circuits in peripheral circuits connected with the drive, and make sure the connection is tight. Failure to comply may result in equipment damage.
- Ø Make sure the motor and associated machinery are within allowable range of service prior to operation. Failure to comply may result in equipment damage.
- Ø Never touch fans, heat sink and braking resistor with bare hands. Failure to comply may result in equipment damage and/or personal injury.
- Ø It is not allowed to start & stop the driver frequently via direct switching power on or off. Failure to comply may result in equipment damage.
- Ø Make sure the drive is in a non-output status before switch-on/switch-off of the drive output and/or contactor. Failure to comply may result in equipment damage.

1.1.5 Maintenance

 **WARNING**

- Ø Only qualified technicians are allowed to implement the maintenance, and troubleshooting.
- Ø Never implement the maintenance, and troubleshooting before power supply has been turned off and discharged completely. Failure to comply may result in equipment damage and/or personal injury.
- Ø To avoid an electric shock hazard, wait at least 10 minutes after the power has been turned off and make sure the residual voltage of the bus capacitors has discharged to 0V before performing any work on the drive.
- Ø After the replacement of the drive, be sure to perform the same procedures in strict accordance with above-noted rules.

 **ATTENTION**

- Ø Do not touch the electric components with bare hands during maintenance, and troubleshooting. Failure to do this may result in component damage due to ESD.
- Ø All pluggable components can be inserted or pulled out only when power has been turned off.

1.2 Other Considerations

1.2.1 Input Power Supply

This series of drives are not applicable to applications out the range of operating voltage as set forth in this manual. If necessary, please use booster to rise or drop the voltage to regulated voltage range.

This series of drives only apply to AC three-phase input voltage. AC two-phase voltage input will cause faults even damage to the drives.

This series of drives support common DC bus input. Users are suggested to consult CG Drives & Automation technical personnel before use.

1.2.2 Surge Protection

This series of drives are furnished with surge suppressor that has certain resistance to lightning induction. However, users in areas with frequent occurrence of lightning need to mount an external surge suppressor in front of the drive power input side.

1.2.3 Operation of Contactor

As to the configuration of peripheral devices recommended by this manual, it is necessary to mount a contactor between the power supply and this drive input side. Such a contactor should not be used as a control device for start and stop of the drive, as frequent charging & discharging shall reduce the service life of internal electrolytic capacitors.

When it is necessary to mount a contactor between the drive output and the motor, it should be ensured the drive is in a non-output status before switch-on/switch-off of such a contactor. Failure to comply may result in drive damage.

1.2.4 Output Filter

Since the drive output is PWM high frequency chopping voltage, mounting filter devices such as an output filter and an output AC reactor between the motor and the drive shall effectively reduce output noise, avoiding interference to other surrounding equipments.

If the length of cable between the drive and the motor exceeds 100m, an output AC reactor is recommended to use with the purpose of preventing drive fault as a result of overcurrent caused by excessive distributed capacitance. An output filter is optional depending on field requirements.

Be sure not to mount phase-shifting capacitor or surge absorber at output side of the drive since this may result in drive damage as a result of over-temperature.

1.2.5 Insulation of the motor

In view of the fact that the drive output is PWM high frequency chopping voltage accompanied by higher harmonics, the noise, temperature rise and vibration of the motor is higher compared with sinusoidal voltage. Particularly this debases motor insulation. Therefore, the motor should be subjected to insulation inspection before initial use or reuse after being stored for a long period of time. The motor in regular service should also be subjected to regular insulation inspection so as to avoid the drive damage as a result of motor insulation damage. A 500V voltage mode mega-ohmmeter is recommended to use for the measurement of the motor insulation, during which, it is essential to disconnect the motor from the drive. Normally, the insulation resistance of the motor should be bigger than 5MΩ.

1.2.6 Derating

Due to the thin air in high-altitude areas, the radiating performance of the drive with forced air cooling may degrade while the electrolyte of electrolytic capacitors is more volatile, which can result in reduction in product life. Drive should be derated when used in an area at the altitude above 1000 meters. It is recommended to derate 1% for every 100m when the altitude is above 1000 meters.

Chapter 2 Product Information

2.1 Model Explanation

Model shown on product nameplate indicates the series name, applicable type of power supply, power class and hardware, etc. via the combination of numbers, symbols and letters.

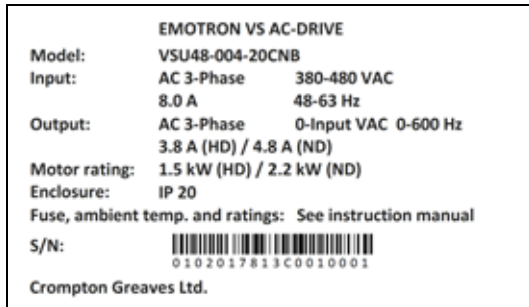

Fig. 2-1 Nameplate information

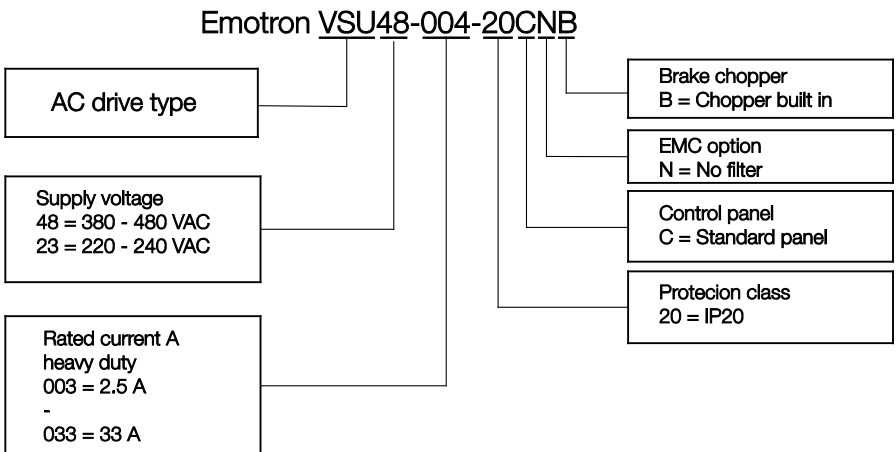

Fig. 2-2 Product model explanation

2.3 Information of Product Model

Table 2-1 Product model and technical data 3 phase, 380-480V

Drive model	Heavy Duty 150% 1 min. every 10 min.			Light Duty 120% 1 min.	Max input Fuse A	Brake unit Ω
	Rated output current A	Rated input current A	Typical motor kW*	Rated output current A		
VSU48-003-20CNB	2.5	3.5	0.75	3.8	10	≥100
VSU48-004-20CNB	3.8	6.2	1.5	4.8	10	≥100
VSU48-006-20CNB	5.5	9.2	2.2	8	16	≥100
VSU48-009-20CNB	9	14.9	3.7	11	20	≥75
VSU48-013-20CNB	13	21.5	5.5	16	30	≥75
VSU48-017-20CNB	17	27.9	7.5	21	35	≥75
VSU48-024-20CNB	24	39	11	30	50	≥30
VSU48-030-20CNB	30	50.3	15	36	63	≥25

* Power at 400 – 415 V

Table 2-2 Product model and technical data 1x230V or 3x230V

Drive model	Heavy Duty 150% 1 min. every 10 min.			Light Duty 120% 1 min	Max input Fuse A	Brake unit Ω
	Rated output current A	Rated input current 1-ph / 3-ph A	Typical motor kW*	Rated output current A		
VSU23-003-20CNB	2.6	5.5 / 3.2	0.4	**	16	≥50
VSU23-005-20CNB	4.5	9.2 / 6.3	0.75		16	≥50
VSU23-008-20CNB	7.5	14.5 / 9	1.5		20	≥40
VSU23-011-20CNB	11	23 / 15	2.2		25	≥40
VSU23-017-20CNB	17	- / 33	3.7		45	≥40
VSU23-025-20CNB	25	- / 39	5.5		63	≥30
VSU23-033-20CNB	33	- / 50.3	7.5		80	≥30

Note: The models VSU23-003, VSU23-005, VSU23-008 and VSU23-11 can be used for either 1-phase or 3-phase.

* Power at 230V. ** = Contact CG for information

2.4 Technical Features of Emotron VSU

Table 2-3 Technical Features of Emotron VSU

Power input	Rated input voltage	3-phase AC208V/AC220V/AC230V/AC240V/AC380V/AC400V/AC415V/AC440V/AC460V/AC480V 1-phase AC220V/AC230V/AC240V
	Rated input current	See Section 2.3
	Frequency	50Hz/60Hz, tolerance $\pm 5\%$
	Allowable range of voltage	Continuous voltage fluctuation $\pm 10\%$, short fluctuation -15% to +10%, i.e. 323V - 528V; Voltage out-of-balance rate <3%, distortion rate as per the requirements of IEC61800-2
Power output	Standard applicable motor (kW)	See Section 2.3
	Rated current (A)	See Section 2.3
	Output voltage (V)	3-phase: 0 - rated input voltage, error < $\pm 3\%$
	Output frequency (Hz)	0.00 - 600.00Hz; unit: 0.01Hz
	Overload capacity	150% - 1min; 180% - 10s; 200% - 0.5s
Control characteristics	V/f patterns	V/f control Sensor-less vector control 1 Sensor-less vector control 2
	Range of speed regulation	1:100 (V/f control, sensor-less vector control 1) 1:200 (sensor-less vector control 2)
	Speed accuracy	$\pm 0.5\%$ (V/f control) $\pm 0.2\%$ (sensor-less vector control 1 & 2)
	Speed fluctuation	$\pm 0.3\%$ (sensor-less vector control 1 & 2)
	Torque response	< 10ms (sensor-less vector control 1 & 2)
	Starting torque	0.5Hz: 180% (V/f control, sensor-less vector control 1) 0.25Hz: 180% (sensor-less vector control 2)

Basic functions	Start frequency	0.00 - 600.00Hz
	Accel/Decel time	0.00 - 60000s
	Carrier frequency	0.7kHz - 16kHz
	Frequency setting sources	Digital setting + keypad \wedge / \vee Digital setting + terminal UP/DOWN Communication Analogue setting (AI1/AI2/EAI) Terminal pulse setting
	Motor started methods	Started from starting frequency DC braking and then started Speed search started
	Motor stopped methods	Ramp to stop Coast to stop Ramp stop + DC brake
Basic functions	Dynamic braking capacity	Brake unit action voltage: 650V - 750V; service time: 0.0 - 100.0s; brake units for EmotronVSU48-030-20CNB and below are built in or can be built in. See table 2-1
	DC braking capacity	DC braking start frequency: 0.00 - 600.00Hz DC braking current: 0.0 - 100.0% DC braking time: 0.0 - 30.00s
	Input terminals	6 digital inputs, one of which can be used for high-speed pulse input. Compatible with active open collectors NPN, PNP and dry contact input. Digital inputs can be extended to 7 2 analogue inputs, one of which is voltage/current programmable, and the other supports voltage only. Analogue inputs can be extended to 3, and the extended one is voltage/current programmable
	Output terminals	1 high-speed pulse output, 0 - 50kHz square wave signal output; can output signals such as command frequency, or output frequency, etc. 1 digital output 1 relay output (can be extended to 2) 1 analogue output (can be extended to 2), voltage/current output programmable; can output signals such as setting frequency, or output frequency, etc

<p>Featured functions</p>	<p>Parameter copy, parameter backup, common DC bus, free switchover between two motors' parameters, flexible parameter displayed & hidden, various master & auxiliary command and switchover, speed search started, a variety of Accel/Decel curves optional, automatic correction of analogue, contracting brake control, 16-step speed control programmable (2-step speed supports flexible frequency command), wobble frequency control, fixed length control, count function, three faults recorded, over excitation brake, over voltage stall protection, under voltage stall protection, restart upon power loss, skip frequency, frequency binding, four kinds of Accel/Decel time, motor thermal protection, flexible fan control, process PID control, simple PLC, multi-functional key programmable, droop control, parameter identification, field-weakening control, high-precision torque restraint, V/f separated control</p>	
<p>Protection functions</p>	<p>Refer to Chapter 7- Troubleshooting</p>	
<p>Environment</p>	<p>Place of operation</p>	<p>Indoors, no direct sunlight, free from dust, corrosive gases, flammable gases, oil mist, water vapor, water drop or salt, etc.</p>
	<p>Altitude</p>	<p>0 - 2000m De-rate 1% for every 100m when the altitude is above 1000 meters</p>
	<p>Ambient temperature</p>	<p>-10°C - 50°C</p>
	<p>Relative humidity</p>	<p>0 - 95%, no condensation</p>
	<p>Vibration</p>	<p>Less than 5.9m/s² (0.6g)</p>
	<p>Storage temperature</p>	<p>-40°C to +70°C</p>
<p>Others</p>	<p>Efficiency at rated Amps</p>	<p>Rated power 7.5kW and below: ≥93% 11 - 15kW: ≥ 95%</p>
	<p>Installation</p>	<p>Wall-mounted</p>
	<p>IP grade</p>	<p>IP20</p>
	<p>Cooling method</p>	<p>Fan cooled</p>

2.5 Parts Drawing

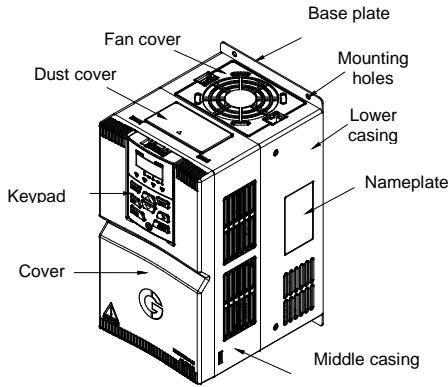

Fig. 2-3 Parts explanation

2.6 Appearance, Mounting Dimensions and Weight

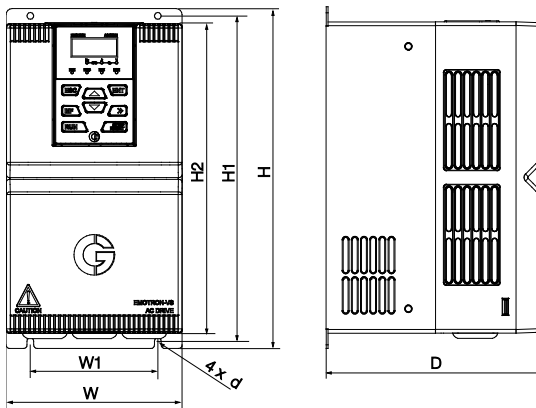

Fig. 2-4 External dimensions

Table 2-4 Appearance, mounting dimensions and weight for 380-480V

Model	External and installation dimensions (mm)							Weight (kg)
	W	H	D	W1	H1	H2	Mounting hole dia. d	
VSU48-003-20CNB	93	190	152	70	180	172	4.5	1.8
VSU48-004-20CNB								
VSU48-006-20CNB	120	245	169	80	233	220	5.5	2.6
VSU48-009-20CNB								
VSU48-013-20CNB	145	280	179	105	268	255	5.5	3.9
VSU48-017-20CNB								
VSU48-024-20CNB	190	365	187	120	353	335	6	5.0
VSU48-030-20CNB								

Table 2-5 Appearance, mounting dimensions and weight for 230V

Model	External and installation dimensions (mm)							Weight (kg)
	W	H	D	W1	H1	H2	Mounting hole dia. d	
VSU23-003-20CNB	93	190	152	70	180	172	4.5	1.8
VSU23-005-20CNB								
VSU23-008-20CNB	120	245	169	80	233	220	5.5	2.6
VSU23-011-20CNB								
VSU23-017-20CNB	145	280	179	105	268	255	5.5	3.9
VSU23-025-20CNB	190	365	187	120	353	335	6	5
VSU23-033-20CNB								

2.7 External Dimensions of Keypad

Keypad model of general purpose Emotron VS series AC motor drive is KBU-BX1 whose appearance and external dimensions are shown in Fig. 2-5.

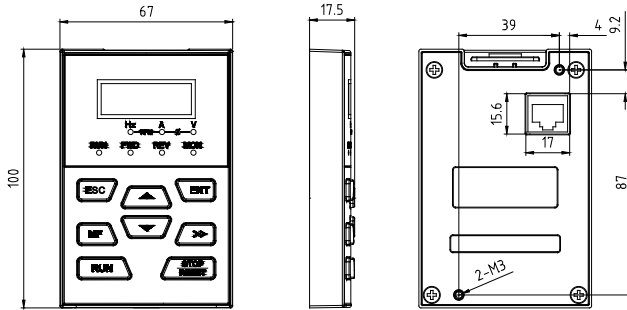
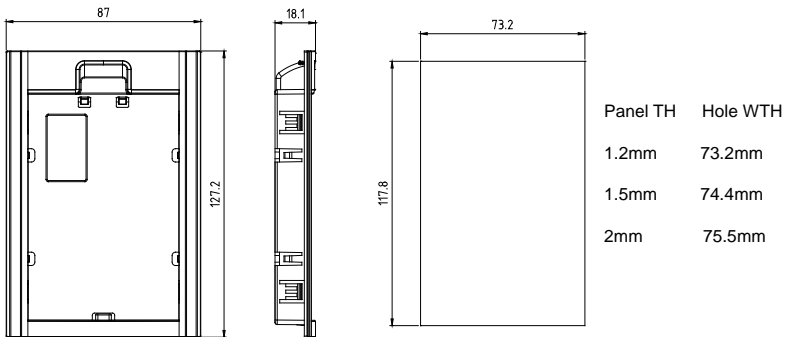

Fig. 2-5 External dimensions of KBU-BX1

2.8 External Dimensions of Keypad Bracket

Where keypad KBU-BX1 needs to be remotely used, located on the electric control cabinet, it should be provided with a bracket to support, and need to open a hole in the cabinet. Bracket model is KBU-DZ1 whose external dimensions are shown in Fig. 2-6 a). Fig. 2-6 b) shows applicable hole dimensions in the cabinet.



a) External dimensions of KBU-DZ1

b) Hole dimensions in the cabinet

Fig. 2-6 External dimensions of KBU-DZ1 and cabinet hole dimensions

Chapter 3 Installation and Wiring

3.1 Installation Environment

- 1) Ambient temperature is in the range of -10°C - 50°C .
- 2) Drive should be installed on surface of flame retardant object, with adequate surrounding space for heat dissipation.
- 3) Installation should be performed where vibration is less than 5.9m/s^2 (0.6g).
- 4) Protect from moisture and direct sunlight.
- 5) Protect the cooling fan by avoiding oil, dust and metal particles;
- 6) Do not expose to an atmosphere with flammable gases, corrosive gases, explosive gases or other harmful gases.
- 7) Prevent drilling residues, wire ends and screws falling into drive.
- 8) Ventilation part of the drive should be installed outside from harsh environment (e.g. textile facilities with fiber particles and chemical facilities filled with corrosive gases).

3.2 Minimum Mounting Clearances

To ensure favorable heat dissipation, mount the drive upright on a flat, vertical and level surface as per Fig. 3.1.

For installation inside cabinet, the product shall be mounted side by side to the greatest extent while adequate surrounding space shall be preserved for favorable heat dissipation.

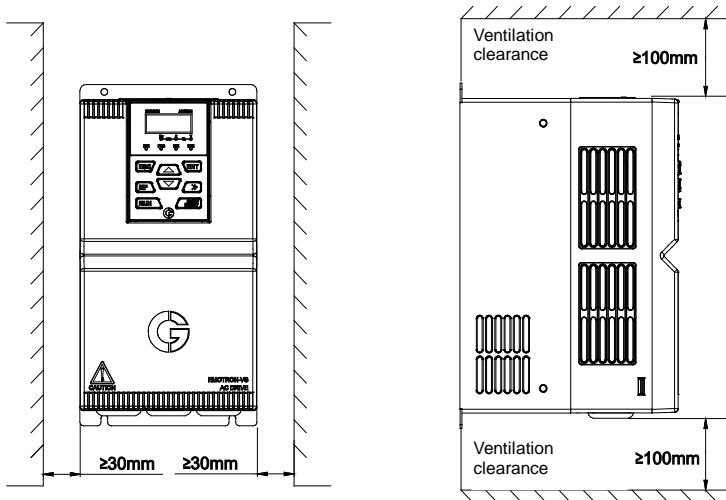

Fig. 3-1 Minimum mounting clearances

& **ATTENTION:**

Remove dust cover when mounting an AC drive in a cabinet. If a number of drives are mounted in one cabinet, parallel side-by-side mounting is recommended.

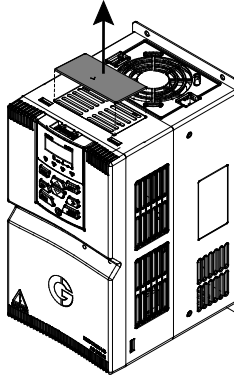

Fig. 3-2 Remove dust cover

3.3 Remove & Mount Keypad and Cover

3.3.1 Remove and Mount Keypad

Ø Remove keypad

Press the buckle of keypad as indicated by number "1" in Fig. 3-3, then pull the keypad out to release as indicated by "2".

Ø Mount keypad

Slightly slant the keypad in the direction as indicated by number "1" in Fig. 3-4 and align it to clamping port at lower part of keypad bracket, then press it in as indicated by "2". When a "click" sound heard, it indicates clamping has been properly made.

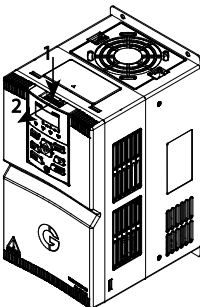

Fig. 3-3 Remove keypad

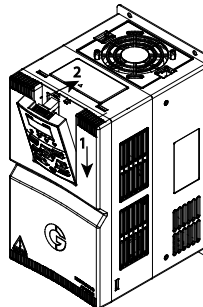

Fig. 3-4 Mount keypad

3.3.2 Open & Mount Covers

- Ø Remove the keypad
Use the remove method as stated in Section 3.3.1.
- Ø Open the cover

Emotron VSU model 003 - 017: Use a sizeable slotted screwdriver to push the buckle slightly at the lower part of the cover to make buckle naturally off the groove, as indicated by "2", pull the cover out to release, as indicated by number "3".

Emotron VSU model 024 - 033: Loosen the captive cover screw with your fingers, as indicated by number "1" in Fig. 3-5

Then use a sizeable slotted screwdriver to push the buckle slightly at the upper part of the cover to make buckle naturally off the groove, as indicated by "2", pull the cover out to release, as indicated by number "3".

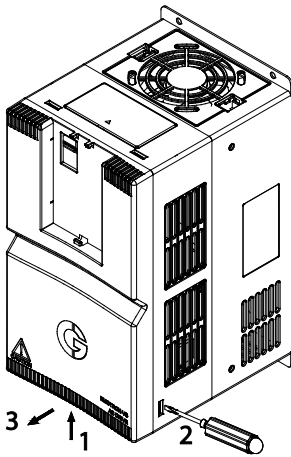

Emotron VSU## 003-017

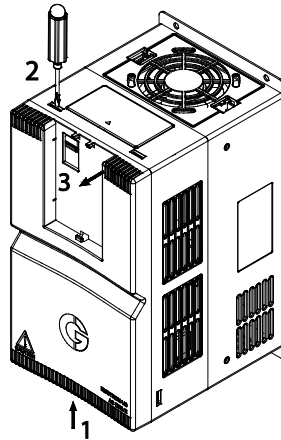

Emotron VSU## 024-033

Fig. 3-5 Open cover

Ø Mount cover

Emotron VSU model 003 – 017 On the completion of wiring, insert the buckle at higher part of the cover into the grooves at middle housing as indicated by number "1" in Fig. 3-6, then push in the lower part of the cover as indicated by "2". When a "click" sound heard, it indicates clamping has been properly made.

Emotron VSU model 024 – 033 On the completion of wiring, insert the buckle at lower part of the cover fitting the screw and the clamps into the groove in the middle housing as indicated by number "1" in Fig.3-6, then push in the upper part of the cover as indicated by "2". When a "click" sound heard, it indicates clamping has been properly made. Tighten the screw with your fingers (a position 1).

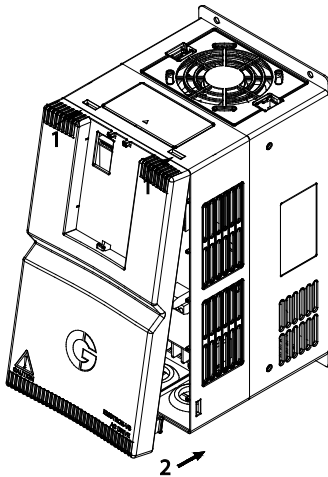

Emotron VSU## 003-017

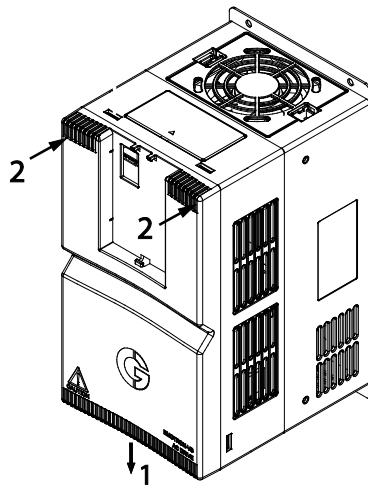

Emotron VSU## 024-033

Fig. 3-6 Mount cover

Ø Mount Keypad

Use the mounting method as stated in Section 3.3.1.

& ATTENTION:

Be sure to remove the keypad before opening the cover and mount the cover before mounting the keypad.

3.4 Configuration of Peripheral Devices

3.4.1 Standard Configuration of Peripheral Devices

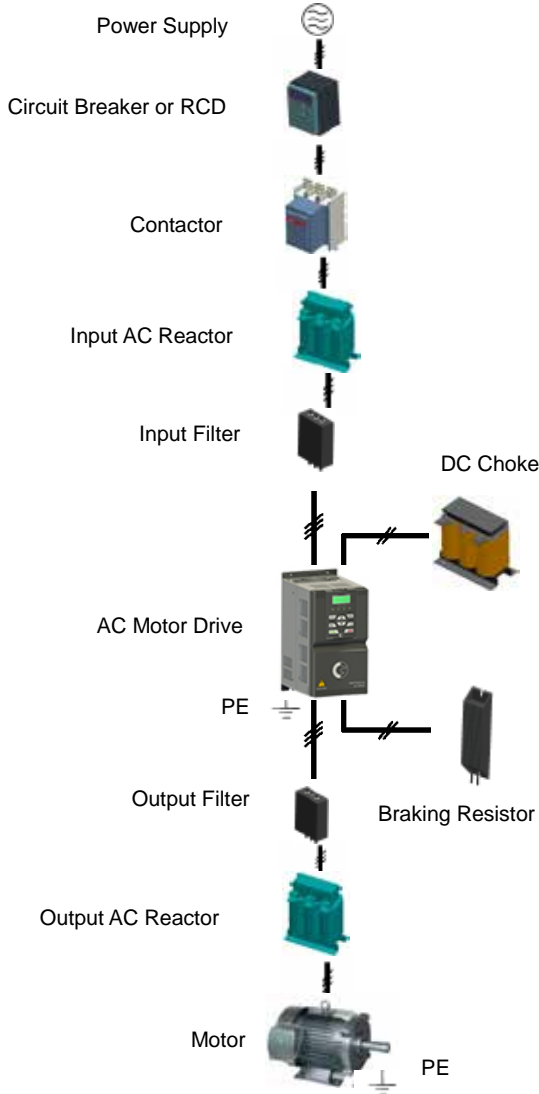

Fig. 3-7 Standard configuration of peripheral devices

3.4.2 Instructions for Peripheral Devices

Table 3-1 Instructions for peripheral devices

Name	Instructions
Power supply	Input three-phase AC power supply should be in the range as specified in this manual
Circuit breaker	Purpose: disconnect power supply and protect the equipments in case of abnormal overcurrent occurs Type selection: breaking current of circuit breaker is defined to be 1.5 - 2 times the rated current of the drive Breaking time characteristic of circuit breaker should be selected based on overload protection time characteristic of the drive
RCD	Purpose: since the drive outputs PWM HF chopping voltage, HF leakage current is inevitable Type selection: type B dedicated RCD is recommended
Contactor	For safety's sake, do not frequently close and break the contactor since this may bring about equipment faults Do not control the start & stop of the drive directly through switch on and off the contactor since this will result in a reduction on the product life
Input AC reactor or DC choke	Improve power factor Reduce the impact of imbalanced three-phase input AC power supply on the system Suppress higher harmonics and reduce the conducted and radiated interference to peripheral devices Restrict the impact of impulse current on rectifier bridges
Input EMC filter	Reduce conducted interference from power supply to the drive, improve the immunity of the drive from noise Reduce conducted and radiated interference of the drive to peripheral devices
Brake unit and braking resistor	Purpose: consume motor feedback energy to attain quick brake Type selection: Contact CG DRIVES & AUTOMATION technical personnel for type selection of brake unit. Refer to type selection of braking resistor in Table 3-3 Type Selection of Peripheral Devices.
Output filter	Reduce conducted and radiated interference of the drive to peripheral devices
Output AC reactor	Avoid the motor insulation damage result from harmonic voltage Reduce frequent protection from the drive caused by leakage current In case the cable connecting drive and motor is over 100 meters, output AC reactor recommended
Motor	Should match the drive

3.4.3 Selection of Peripheral Devices

Table 3-2 Selection of peripheral devices for 3-phase 380-480V

Drive model	Circuit breaker A	Contactor A	Brake resistor/brake unit	
			Resistor Power W	Resistance Ω *
VSU48-003-20CNB	6	9	150	≥ 100
VSU48-004-20CNB	10	9	150	≥ 100
VSU48-006-20CNB	16	12	300	≥ 100
VSU48-009-20CNB	25	18	450	≥ 100
VSU48-013-20CNB	32	25	500	≥ 75
VSU48-017-20CNB	40	38	500	≥ 75
VSU48-024-20CNB	63	50	800	≥ 30
VSU48-030-20CNB	63	65	1000	≥ 25

Table 3-3 Selection of peripheral devices for 3-phase 230V

Drive model	Circuit breaker A	Contactor A	Brake resistor/brake unit	
			Resistor Power W	Resistance Ω *
VSU23-003-20CNB	6	9	100	≥ 50
VSU23-005-20CNB	10	9	150	≥ 50
VSU23-008-20CNB	16	12	150	≥ 40
VSU23-011-20CNB	25	18	300	≥ 40
VSU23-017-20CNB	40	38	450	≥ 40
VSU23-025-20CNB	50	50	500	≥ 30
VSU23-033-20CNB	63	65	500	≥ 30

Table 3-4 Selection of peripheral devices for 1-phase 230V

Drive model	Circuit breaker A	Contactor A	Brake resistor/brake unit	
			Resistor Power W	Resistance Ω *
VSU23-003-20CNB	10	9	100	≥ 50
VSU23-005-20CNB	16	12	150	≥ 50
VSU23-008-20CNB	25	18	150	≥ 40
VSU23-011-20CNB	32	25	300	≥ 40

* On the premise of fulfilling brake requirement, brake resistance value might be bigger than the minimum value as stated in the table. Failure to comply may result in product damage. Brake resistors are not built in and need to be sourced additionally.

Recommended DC choke

Table 3-5 Recommended DC choke for 3-phase 400V

Drive model 3-phase	Power kW	Supply voltage 400V 50-60Hz	
		Choke rated Current Amps,DC	Inductance mH
VSU48-003-20CNB	0.75	4	25
VSU48-004-20CNB	1.5	9	11.5
VSU48-006-20CNB	2.2	9	11.5
VSU48-009-20CNB	3.7	12	6
VSU48-013-20CNB	5.5	18	4.8
VSU48-017-20CNB	7.5	25	4
VSU48-024-20CNB	11	32	2.7
VSU48-030-20CNB	15	50	2

Table 3-6 Recommended DC choke 230V

Drive model	Power kW	Supply voltage 230V 50-60Hz	
		Choke rated Current Amps,DC	Inductance mH
		3-phase 230V	
VSU23-003-20CNB	0.4	9	7.5
VSU23-005-20CNB	0.75	9	7.5
VSU23-008-20CNB	1.5	12	4
VSU23-011-20CNB	2.2	18	2.75
VSU23-017-20CNB	3.7	25	1.75
VSU23-025-20CNB	5.5	32	0.85
VSU23-033-20CNB	7.5	40	0.75
1-phase 230V			
VSU23-003-20CNB	0.4	9	12
VSU23-005-20CNB	0.75	9	12
VSU23-008-20CNB	1.5	12	8
VSU23-011-20CNB	2.2	18	6

3.5 Terminal Configuration

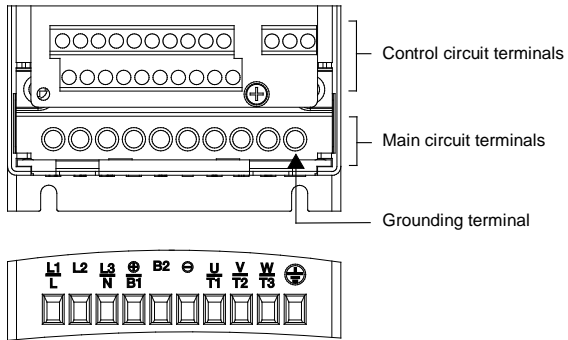

Fig. 3-8 Terminal configuration for model Emotron VSU##-003 to VSU##-005.

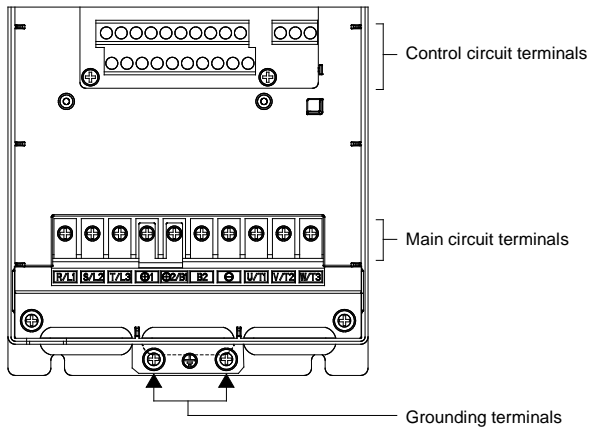

Fig. 3-9 Terminal configuration for Emotron VSU48-006 and up, VSU23-008 and up.

3.6 Main Circuit Terminals and Wiring



WARNING

- Ø Only qualified personnel familiar with AC motor drives are allowed to implement wiring. Failure to comply may result in equipment damage and/or personnel injury even death.
- Ø Wiring should be in strict accordance with this manual, otherwise hazard of electric shock or equipment damage exists.
- Ø Make sure input power supply has been completely disconnected before wiring operation. Failure to comply will result in personnel injury even death.
- Ø All wiring operations and lines should comply with EMC and national and local industrial safety regulations and/or electrical codes. The conductor diameter should be in accordance with recommendations of this manual. Otherwise, hazard of equipment damage, fire, and/or personnel injury exists.
- Ø Since leakage current of the drive may exceed 3.5mA, for safety's sake, the drive and the motor must be grounded so as to avoid hazard of electric shock.
- Ø Be sure to perform wiring in strict accordance with the drive terminal marks. Never connect three-phase power supply to output terminals U/T1, V/T2 and W/T3. Failure to comply will result in equipment damage.
- Ø Only mount braking resistors at terminals $\oplus 2/B1$ and B2 when needed.
- Ø When needed, only mount DC reactors at terminals $\oplus 1$ and $\oplus 2$, and remove the jumper connected between $\oplus 1$ and $\oplus 2$. Never connect the jumper and DC reactor to other terminals since this will result in short circuit and equipment damage.
- Ø Wiring screws and bolts for main circuit terminals must be screwed tightly. Failure to comply may result in faults and/or equipment damage.



ATTENTION

- Ø Signal wires should to the best of possibility be away from main power lines. In the event that this cannot be ensured, vertical cross arrangement should be adopted, reducing EMI interference to the signal wires as much as possible.
- Ø In case the motor cable exceeds 100m, an appropriate output reactor should be mounted.

3.6.1 Main Circuit Terminals

Emotron VSU48-003, VSU48-004, VSU23-003 and VSU23-005

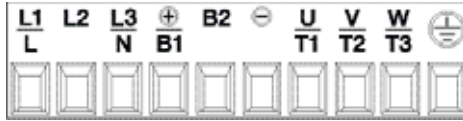

Terminal marks	Designation and function of terminals
L1/L, L2, L3/N	Three-phase AC input terminals. Models VSU23-003 and VSU23-005 can also be connected as single phase, then connect to L1/L and L3/N .
+/B1, B2	Braking resistor connection terminals
B2, -	DC input terminals of externally mounted brake unit
U/T1, V/T2, W/T3	Three-phase AC output terminals
⊕	Ground terminal PE

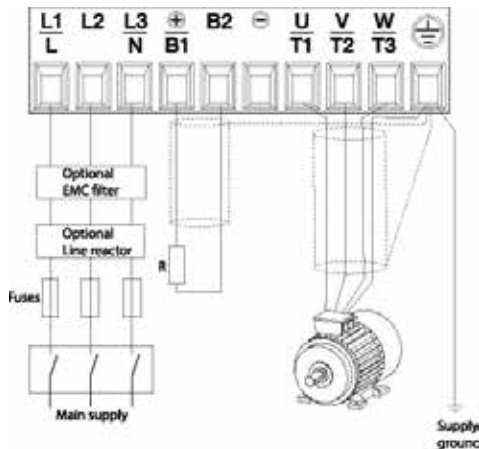

Fig. 3-10 Typical wiring example for 3-phase Mains supply

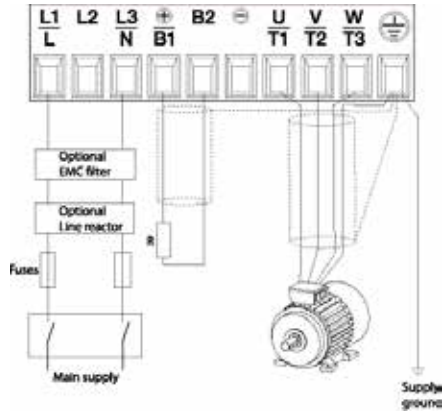
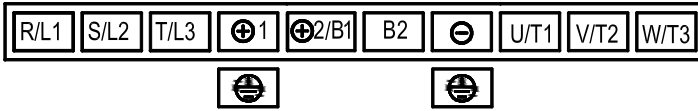

Fig. 3-11 Typical wiring example for single-phase Mains supply. Single phase is possible for models VSU23-003 and VSU23-005.

Emotron VSU48-006 and up, VSU23-008 and up



Terminal marks	Designation and function of terminals
R/L1, S/L2, T/L3	Three-phase AC input terminals. Models VSU23-008 and VSU23-011 can also be connected as single phase, then connect to R/L1 and T/L3.
⊕1 , ⊕2/B1	DC reactor connection terminals. Connected to +2/B1 with a jumper as factory default
⊕2/B1 , B2	Braking resistor connection terminals
⊕2/B1 , ⊖	DC input terminals of externally mounted brake unit
⊕1 , ⊖	DC power supply input terminals
U/T1, V/T2, W/T3	Three-phase AC output terminals
⊕	Ground terminal PE

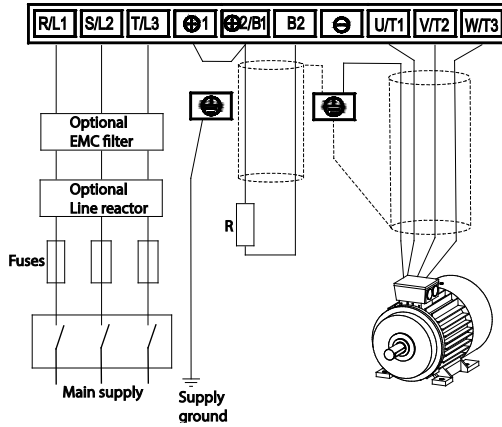

Fig. 3-12 Typical wiring example for 3-phase Mains supply

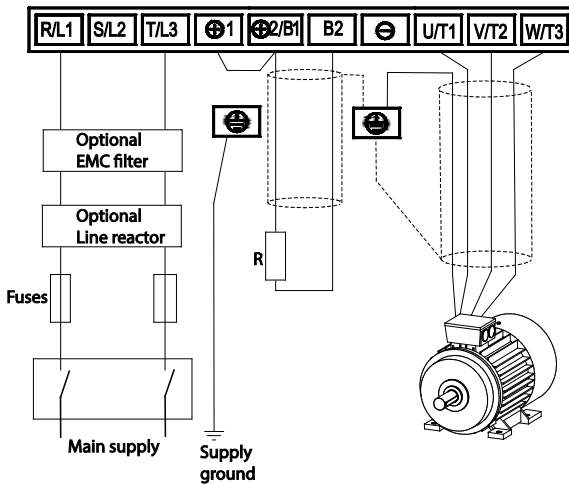

Fig. 3-13 Typical wiring example for single-phase Mains supply.
Single phase is possible for models VSU23-008 to VSU23-011.

3.6.4 Terminal Screws and Wiring Requirement

Table 3-7 Terminal screws and wiring requirement for 380-480V

Drive model	Power terminal			Ground terminal		
	Cable requirement mm ²	Screw	Torque Nm/Lb-In	Cable requirement mm ²	Screw	Torque Nm/Lb-In
VSU48-003-20CNB	2.5	M3.5	0.8/7	2.5	M3.5	0.8/7
VSU48-004-20CNB	2.5	M3.5	0.8/7	2.5	M3.5	0.8/7
VSU48-006-20CNB	2.5	M4	1.4/12	2.5	M4	1.4/12
VSU48-009-20CNB	4	M4	1.4/12	4	M4	1.4/12
VSU48-013-20CNB	6	M4	1.4/12	6	M4	1.4/12
VSU48-017-20CNB	6	M4	1.4/12	6	M4	1.4/12
VSU48-024-20CNB	6	M5	2.7/24	6	M5	2.7/24
VSU48-030-20CNB	6	M5	2.7/24	6	M5	2.7/24

Table 3-8 Terminal screws and wiring requirement for 230V

Drive model	Power terminal			Ground terminal		
	Cable requirement mm ²	Screw	Torque Nm/Lb-In	Cable requirement mm ²	Screw	Torque Nm/Lb-In
VSU23-003-20CNB	2.5	M3.5	0.8/7	2.5	M3.5	0.8/7
VSU23-005-20CNB	2.5	M3.5	0.8/7	2.5	M3.5	0.8/7
VSU23-008-20CNB	4	M4	1.4/12	4	M4	1.4/12
VSU23-011-20CNB	4	M4	1.4/12	4	M4	1.4/12
VSU23-017-20CNB	6	M4	1.4/12	6	M4	1.4/12
VSU23-025-20CNB	6	M5	2.7/24	6	M5	2.7/24
VSU23-033-20CNB	6	M5	2.7/24	6	M5	2.7/24

3.7 Control Terminal Wiring

WARNING

- Ø Only qualified personnel familiar with AC motor drives are allowed to implement wiring. Failure to comply may result in equipment damage and/or personnel injury even death.
- Ø Wiring should be in strict accordance with this manual, otherwise hazard of electric shock or equipment damage exists.
- Ø Make sure input power supply has been completely disconnected before wiring operation. Failure to comply will result in personnel injury even death.
- Ø All wiring operations and lines should comply with EMC and national and local industrial safety regulations and/or electrical codes. The conductor diameter should be in accordance with recommendations of this manual. Otherwise, hazard of equipment damage, fire, and/or personnel injury exists.
- Ø Screws or bolts for terminal wiring must be screwed tightly.
- Ø AC 220V signal is prohibited from connecting to other terminals than control terminals RA, RB and RC.

ATTENTION

- Ø Signal wires should to the best of possibility be away from main power lines. If this cannot be ensured, vertical cross arrangement should be adopted, reducing EMI interference to the signal wires as much as possible.
- Ø Coder must be provided with shielded cables whose shielded layer must be properly grounded.

3.7.1 Control Board Diagram

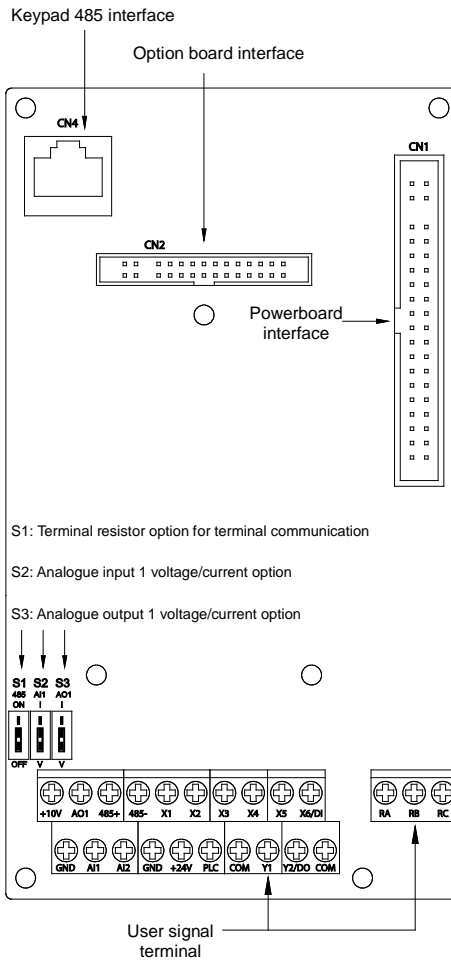

Fig. 3-14 Control board diagram

3.7.2 Wiring Diagram

Emotron VSU48-003, VSU48-004, VSU23-003 and VSU23-0055

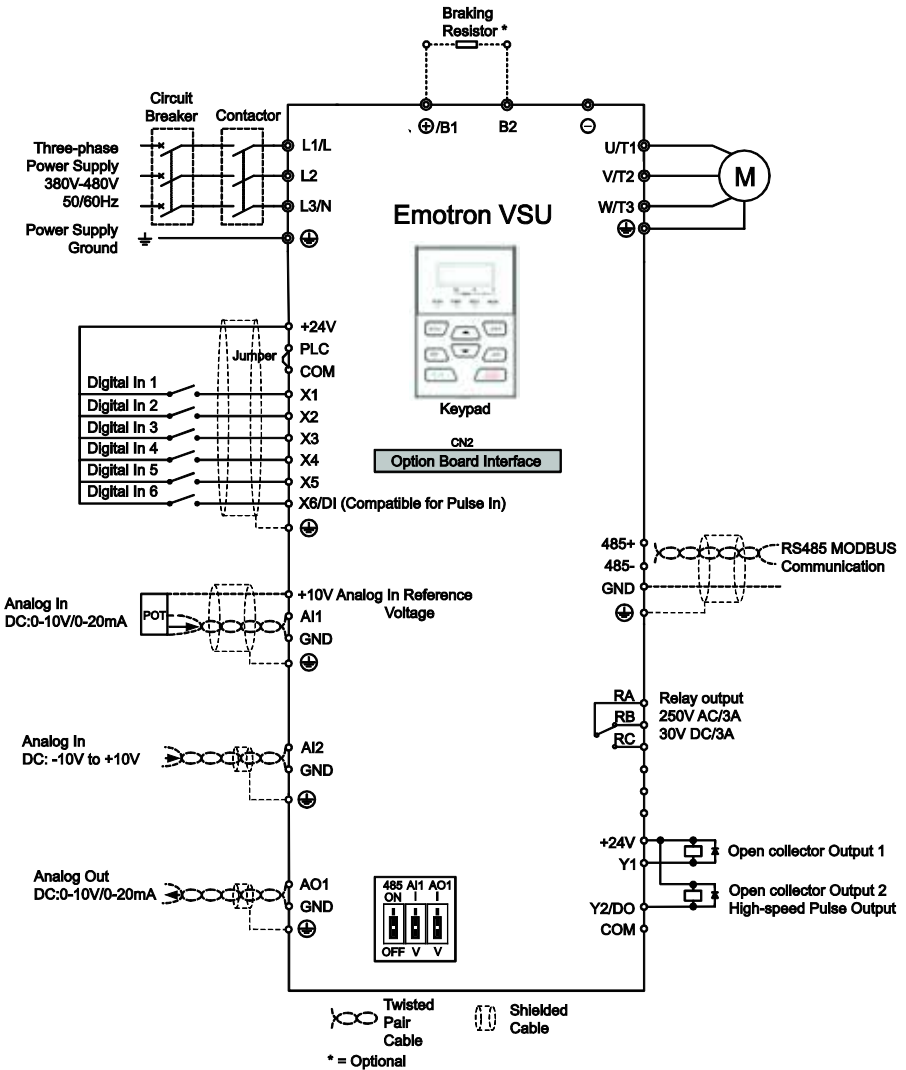

Fig. 3-15 Wiring diagram for Emotron VSU48-003, VSU48-004, VSU23-003 and VSU23-005.

Emotron VSU48-006 and up, VSU23-008 and up

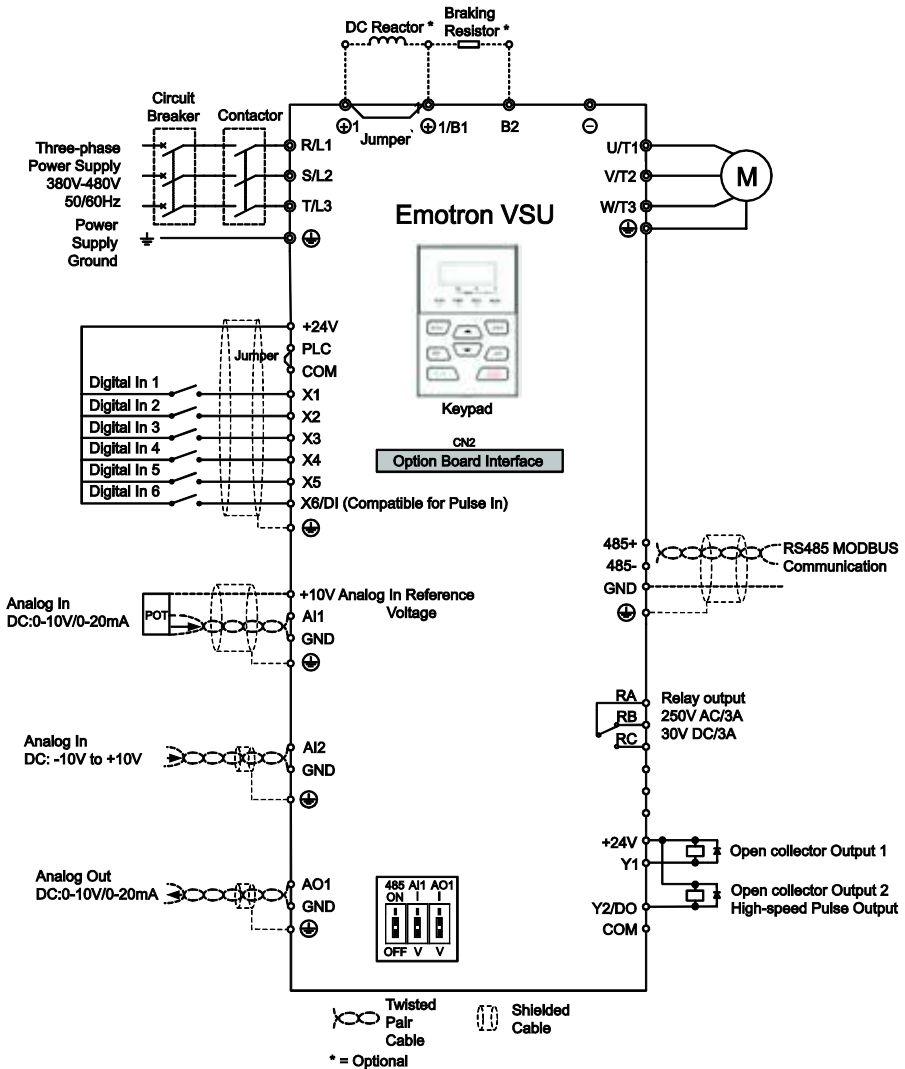

Fig. 3-16 Wiring diagram for Emotron VSU48-006 and up, VSU23-008 and up.

3.8 Control Terminal Specification

Table 3-9 Control terminal specification

Category	Terminal	Terminal designation	Specification
Analogue input	+10V	Analogue input reference voltage	10.3V \pm 3%
			Maximum output current 25mA The resistance of external potentiometer should be larger than 400 Ω
	GND	Analogue ground	Isolated from COM interiorly
	AI1	Analogue input 1	0 - 20mA: input impedance - 500 Ω , maximum input current - 25mA
			0 - 10V: input impedance - 100k Ω , maximum input voltage - 12.5V
	AI2	Analogue input 2	Switch S2 on control board for jumping from 0 - 20mA and 0 - 10V, factory default: 0 - 10V
-10V to 10V: input impedance - 25k Ω Range: -12.5V to + 12.5V			
Analogue output	AO1	Analogue output 1	0 - 20mA: impedance - 200 Ω - 500 Ω
			0 - 10V: impedance \geq 10k
			Switch S3 on control board for jumping between 0 - 20mA and 0 - 10V, factory default: 0 - 10V
GND	Analogue ground	Isolated from COM interiorly	
Digital input	+24V	+24V	24V \pm 10%, Isolated from GND interiorly
			Maximum load - 200mA
	PLC	DI- Digital input Common terminal	Used for switching between high and low levels, jumpered to +24V (factory default), i.e. low value of digital input valid
			External power input
	COM	+24V ground	Isolated from GND interiorly
	X1 - X5	Digital input Terminals 1 - 5	Input: 24VDC, 5mA
Range of frequency: 0 - 200Hz			
Range of voltage: 10V - 30V			
X6/DI	Digital input/pulse input	Digital input: same as X1 - X5	
		Pulse input: 0.1Hz - 50kHz; range of voltage: 10-30V	
Digital output	Y1	Open collector output	Range of voltage: 0 - 24V
			Range of current: 0 - 50mA

Category	Terminal	Terminal designation	Specification
	Y2/DO	Open collector out / Pulse out	Open collector output: same as Y1 Pulse output: 0 - 50kHz;
Relay output	RA/RB/RC	Control board relay output	RA-RB: NC; RA-RC: NO Contact capacity: 250VAC/3A, 30VDC/3A
RS485 Terminal Interface	485+	RS485 differential signal +	Rate: 4800/9600/19200/38400/57600/115200bps
	485-	RS485 differential signal -	Maximum distance - 500m (standard network cable used)
	GND	RS485 communication shield grounding	Isolated from COM interiorly
Category	Connector	Connector designation	Specification
Keypad RS485 interface	CN4	Keypad RS485 interface	Maximum communication distance is 15m when connected to Keypad Use standard network cable

3.9 Control Terminal Usage

3.9.1 Lay-out of Control Terminals

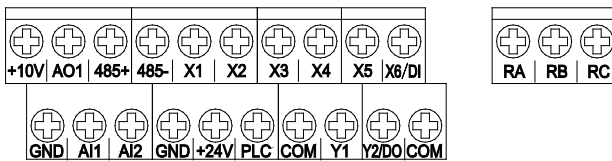

Fig. 3-17 Lay-out of control terminals

3.9.2 Control Terminal Screw and Wiring Requirement

Table 3-10 Terminal screw and wiring specification

Cable type	Cable requirement (mm ²)	Screw	Torque (Nm/Lb-In)
Shielded cable	1.0	M3	0.5 / 4.4

3.9.3 Instructions of Analogue Input/Output Terminals

Being particularly vulnerable to noise, analogue input & output signals cables should be as short as possible, shielded, and their shielded layers should be properly grounded close to the

side of drive. The cables should not exceed 20m.

Control cables shall be kept no less than 20cm away from main circuit and strong current lines (e.g. power lines, motor lines, relay lines and contactor lines) and should not be arranged in parallel with strong current lines. In case it is inevitable to intersect strong current line, vertical wiring is recommended to avoid drive faults as a result of noise.

Where analogue input & output signals are severely interfered, the side of analogue signal source should be provided with filter capacitor or ferrite core.

3.9.4 Instructions of Digital Input/Output Terminals

Digital input & output signals cables should be as short as possible, shielded, and their shielded layers should be properly grounded close to the side of drive. The cables should not exceed 20m. When active drive is selected, take necessary filtering measures against power crosstalk, for which dry contact control is recommended.

Control cables shall be kept no less than 20cm away from main circuit and strong current lines (e.g. power lines, motor lines, relay lines and contactor lines) and should not be arranged in parallel with strong current lines. In case it is inevitable to intersect strong current line, vertical wiring is recommended to avoid drive faults as a result of noise. Operating instructions for switching value input terminal

Ø Instructions of digital input terminal

u Dry contact

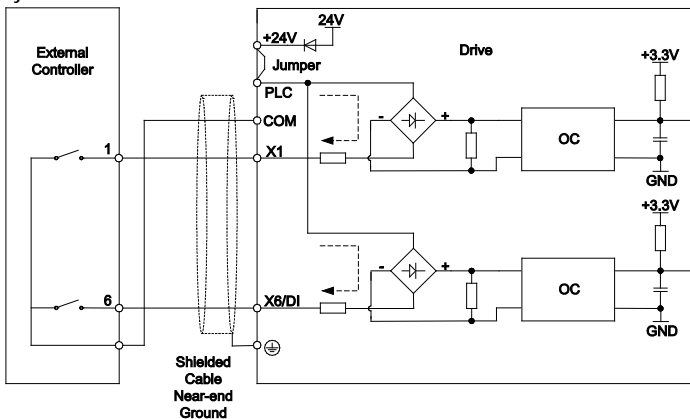

Fig. 3-18 Internal power supply utilized dry contact

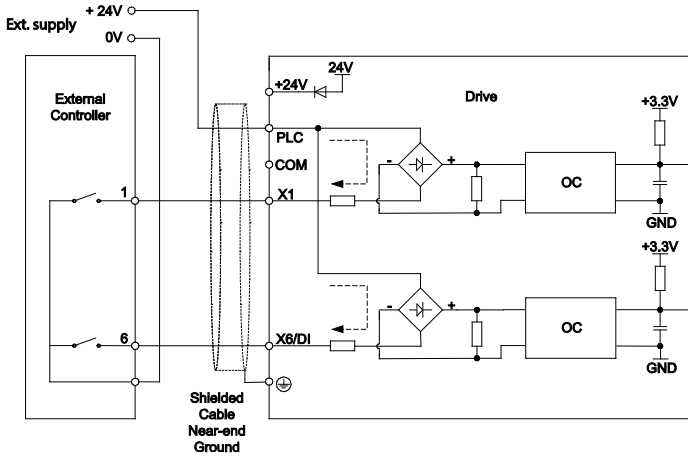

Fig. 3-19 External power supply dry contact

& ATTENTION:

When external power supply is used, the jumper between +24V and PLC must be removed. Otherwise, it may result in equipment damage.

The voltage range of external power supply should be DC20 - 30V. Otherwise, normal operation could not be assured and/or result in equipment damage.

u Open collector NPN connection

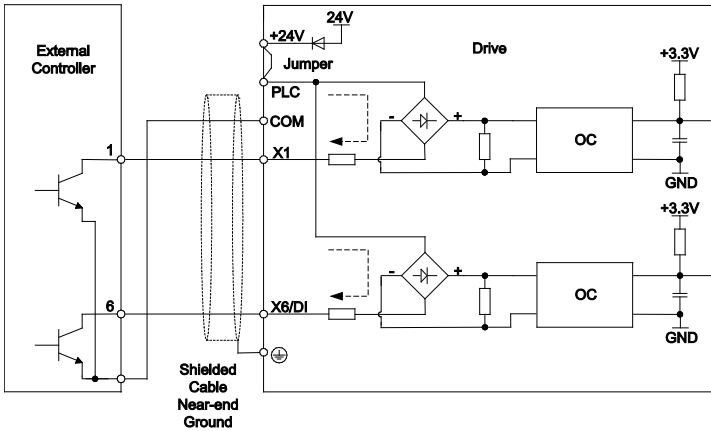

Fig. 3-20 Internal power supply open collector NPN connection

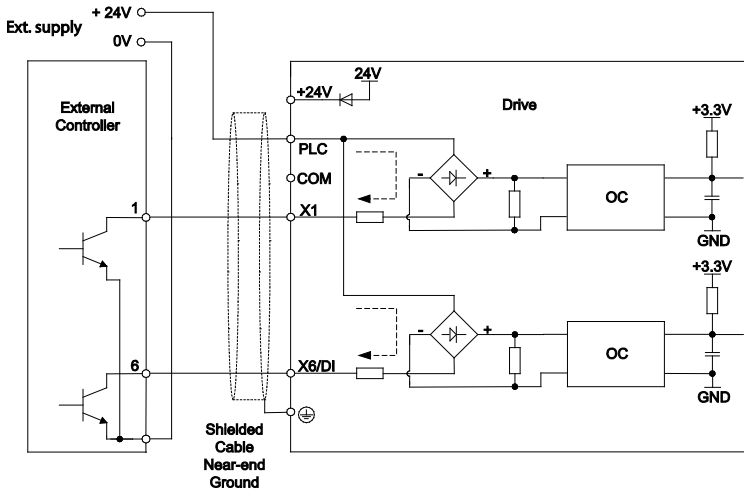

Fig. 3-21 External power supply open collector NPN connection

& ATTENTION:

When external power supply is used, the jumper between +24V and PLC must be removed. The voltage range of external power supply should be DC20 - 30V, otherwise normal operation could not be assured and/or hazard of equipment damage exists.

u Open collector PNP connection

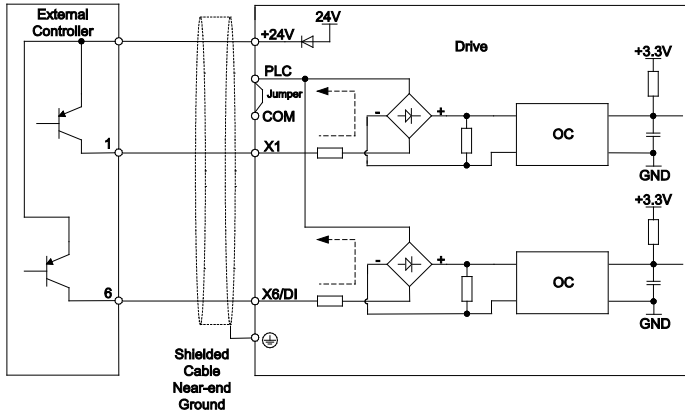

Fig. 3-22 Internal power supply open collector PNP connection

& ATTENTION:

When PNP connection is adopted, it is necessary to remove the jumper between +24V and PLC, and connect the jumper to PLC and COM.

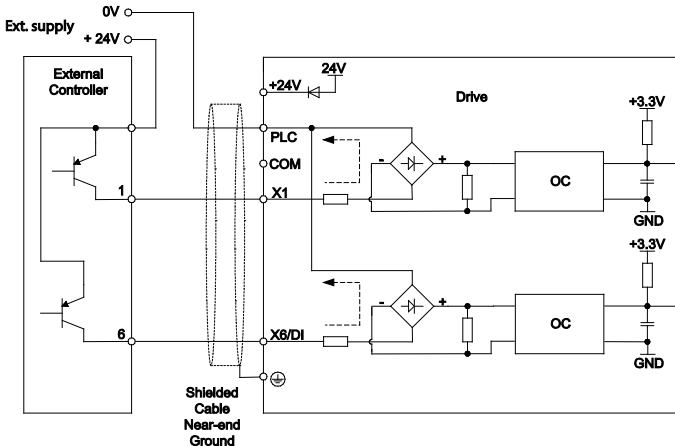

Fig. 3-23 External power supply open collector PNP connection

& ATTENTION:

When external power supply is used, the jumper between +24V and PLC must be removed. The voltage range of external power supply should be DC20 - 30V. Otherwise, normal operation could not be assured and/or hazard of equipment damage exists.

Ø Instructions of digital output terminal

u Instructions of Y1 and Y2/DO output terminals

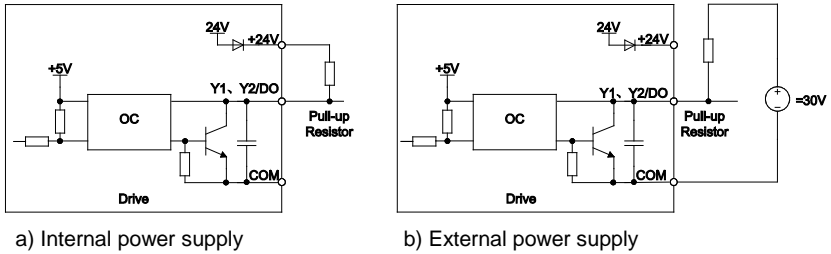

Fig. 3-24 Wiring when Y1 and Y2/DO output with pull-up resistor

& ATTENTION:

When set to be pulse output, Y2/DO terminal shall output 0 - 50kHz pulse signal.

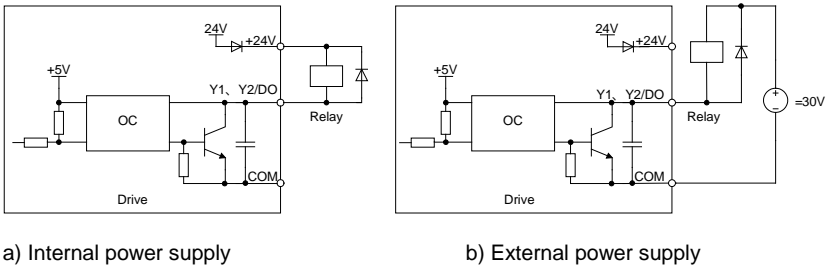

Fig. 3-25 Wiring when Y1 and Y2/DO drive relay

Relay output

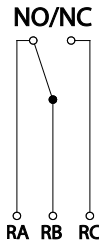

Fig. 3-26 Relay output terminal

& ATTENTION:

When relay coil voltage is lower than 24V, a resistor as voltage divider should be mounted

between relay and output terminal, based on coil impedance.

⌋ Wiring instruction of relay output terminal

Control board of Emotron VS series drive is provided with a group of programmable relay dry contact outputs. RA/RB/RC are relay contacts. RA and RB are normally closed, while RA and RC are normally open. See parameter C1-02 for details.

& ATTENTION:

In case inductive load (e.g. electromagnetic relay or contactor) is to be driven, a surge voltage absorbing circuit such as RC absorbing circuit (note that its leakage current shall be less than holding current of controlled contactor or relay), piezoresistor or fly-wheel diode etc. shall be mounted (be sure to pay close attention to polarity in case of DC electromagnetic circuit). Absorbing devices should be mounted close to the ends of relay or contactor.

3.10 Instruction of Signal Switches

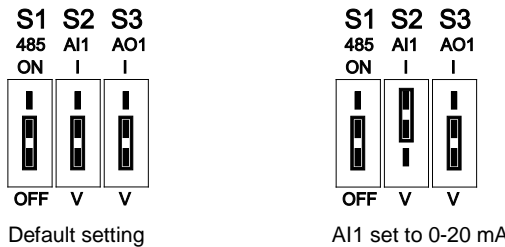

Fig. 3-27 Jumper diagram of signal switching

Designation	Function	Default setting
485	Selection of 485 termination resistor; ON :100Ω termination resistor provided; OFF: no termination resistor	No termination resistor
AI1	I: current input (0 - 20mA); V: voltage input (0 - 10V)	0 - 10V
AO1	I: current output (0 - 20mA); V: voltage output (0 - 10V)	0 - 10V

3.11 EMI Solutions

Due to its working principle, the drive will inevitably produce certain noise that may influence and disturb other equipment. Moreover, since the internal weak electric signal of drive is also susceptible to the interference of drive itself and other equipment, EMI problems shall be inevitable. In order to reduce or avoid the interference of drive to external environment and protect drive against interference from external environment, this section makes a brief

description of noise abatement, ground handling, leakage current suppression and the application of power line filters.

3.11.1 Noise Abatement

- Ø When peripheral equipment and drive share the power supply of one system, noise from drive may be transmitted to other equipment in this system via power lines and result in misoperation and/or faults. In such a case, the following measures could be taken:
 - 1) Mount input noise filter at input terminal of the drive;
 - 2) Mount power supply filter at power input terminal of affected equipment;
 - 3) Use isolation transformer to isolate the noise transmission path between other equipment and the drive.
- Ø As the wiring of peripheral equipment and drive constitutes a circuit, the unavoidable earthing leakage current of inverter will cause equipment misoperation and/or faults. Disconnect the grounding connection of equipment may avoid this misoperation and/or faults
- Ø Sensitive equipment and signal lines shall be mounted as far away from drive as possible.
- Ø Signal lines should be provided with shielded layer and reliably grounded. Alternatively, signal cable could be put into metallic conduits between which the distance shall be no less than 20cm, and shall be kept as far away from drive and its peripheral devices, cables as possible. Never make signal lines in parallel with power lines or bundle them up.
- Ø Signal lines must orthogonally cross power lines if this cross inevitable.
- Ø Motor cables shall be placed in thick protective screen like more than 2mm-thick pipelines or buried cement groove, also, power lines can be put into metallic conduit and grounded well with shielded cables.
- Ø Use 4-core motor cables of which one is grounded at close side of the drive and the other side is connected to motor enclosure.
- Ø Input and output terminals of drive are respectively equipped with radio noise filter and linear noise filter. For example, ferrite common mode choke can restrain radiation noise of power lines.

3.11.2 Grounding

Recommended ground electrode is shown in the figure below:

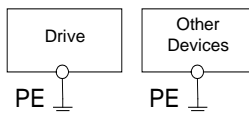

Fig. 3-28 Ground

- Ø Use to the fullest extent the maximum standard size of grounding cables to reduce the impedance of grounding system;

- Ø Grounding wires should be as short as possible;
- Ø Grounding point shall be as close to the drive as possible;
- Ø One wire of 4-core motor cables shall be grounded at the drive side and connected to grounding terminal of motor at the other side. Better effect will be achieved if motor and drive are provided with dedicated ground electrodes;
- Ø When grounding terminals of various parts of system are linked together, leakage current turns into a noise source that may influence other equipment in the system, thus, grounding terminals of the drive and other vulnerable equipment should be separated.
- Ø Grounding cable shall be kept away from inlet & output of noise-sensitive equipment.

3.11.3 Leakage Current Suppression

Leakage current passes through the line-to-line and ground distributed capacitors at input & output sides of drive, and its size is associated with the capacitance of distributed capacitor and the carrier frequency. Leakage current is classified into ground leakage current and line-to-line leakage current.

- Ø Ground leakage current not only circulates inside drive system, but may also influence other equipment via ground loop. Such a leakage current may result in malfunction of RCD and other equipment. The higher the carrier frequency of drive is, the bigger the ground leakage current would be. The longer the motor cables and the bigger the parasitic capacitance are, the bigger the ground leakage current would be. Therefore, the most immediate and effective method for suppression of ground leakage current is to reduce carrier frequency and minimize the length of motor cables.
- Ø The higher harmonics of line-to-line leakage current that passes through between cables at output side of drive will accelerate the aging of cables and may bring about malfunction of other equipment. The higher the carrier frequency of drive is, the bigger the line-to-line leakage current would be. The longer the motor cables and the bigger the parasitic capacitance are, the bigger the line-to-line leakage current would be. Therefore, the most immediate and effective method for suppression of ground leakage current is to reduce carrier frequency and minimize the length of motor cable. Line-to-line leakage current can also be effectively suppressed by mounting additional output reactors.

3.11.4 Use of Power Supply Filter

Since AC drives may generate strong interference and are also sensitive to outside interference, power supply filters are recommended. Pay close attention to the following instructions during the use:

- Ø Enclosure of the filter needs to be reliably grounded;
- Ø Input lines of the filter shall be kept as far away from output lines as possible so as to avoid mutual coupling;
- Ø Filter shall be as close to the drive side as possible;
- Ø Filter and drive must be connected to the same common ground.

Chapter 4 Operation and Run Instructions

4.1 Operation of Keypad

As a human-machine interface, keypad is the main part for the drive to receive command and display parameters.







Fig. 4-1 Keypad

4.1.1 Key Functions on Keypad

On keypad there are 8 keys whose functions are as shown in Table 4-1.

Table 4-1 Key functions on keypad

Symbol	Key name	Meaning
	Enter key	1) Function code edition enter 2) Confirmation of parameter settings 3) Confirmation of MF key function
	Escape key	1) Return function 2) Invalid parameter edit value
	Increase key	1) Increase of selected bit of function code 2) Increase of selected bit of parameter 3) Increase of set frequency
	Decrease key	1) Decrease of selected bit of function code 2) Decrease of selected bit of parameter 3) Decrease of set frequency





Symbol	Key name	Meaning
	Shift key	1) Selection of function code bit 2) Selection of parameter bit 3) Selection of stop/run status display parameters 4) Fault status switches to parameter display status
	Run key	Run
	Stop/reset key	1) Stop 2) Fault reset
	Multi-function key	See Table 4-2 " MF key function definition"

Table 4-2 MF key function definition

L0-00 set value	Function of MF key	Meaning
0	Disabled	MF key disabled
1	Forward JOG	Forward JOG function
2	Reverse JOG	Reverse JOG function
3	Forward/Reverse switch	Running direction forward and reverse switching
4	Emergency STOP 1	Press  to STOP, with ramp-down time b2-09
5	Emergency STOP 2	Coast to stop, the drive cuts off output
6	Run command setting mode switch	Keypad control -> Terminal control -> Communication control -> Keypad control, press  to confirm within 5 seconds

4.1.2 Keypad Indicators

Keypad is furnished with 7 indicators whose descriptions are as below

Table 4-3 Description of indicators

Indicator	Designation	Meaning
Hz	Frequency indicator	ON: currently displayed parameter is running frequency or the current function code unit is frequency Flash: currently displayed parameter is set frequency
A	Current indicator	ON: currently displayed parameter is current
V	Voltage indicator	ON: currently displayed parameter is voltage
Hz+A	Running speed indicator	ON: currently displayed parameter is running speed Flash: currently displayed parameter is setting speed
A+V	Percentage indicator	ON: currently displayed parameter is percentage
All OFF	No unit	No unit
MON	Run command setting mode indicator	ON: Keypad OFF: Terminal Flash: Communication
RUN	Running status indicator	ON: Running OFF: Stopped Flash: in process of stop
FWD	Forward indicator	ON: If the drive in stop status, forward command enabled. If the drive in running status, the drive is running forward Flash: Forward is being switched to reverse
REV	Reverse indicator	ON: If the drive in stop status, reverse command enabled. If the drive in running status, the drive is running reversely. Flash: Reverse is being switched to forward

4.1.3 Keypad Display Status

Keypad indicates eight types of status, STOP parameters display, Running parameters display, Fault display, parameter number edition, parameter setting, Password authentication, Direct frequency modification and Prompt message. The operation relating to these statuses and the switching among these statuses is described as follows.

4.1.3.1 Display of STOP Parameters

Drive normally gets into STOP parameters display once running stopped. By default, set frequency is displayed in such a status, and other parameters can be displayed through setting of L1-02 parameters and the **>>** key. For example, when users need to check set frequency as well as the values of bus voltage and AI1 value in stop status, make L1-02=0013 (refer to setting method of parameters) and press the **>>** key to display the value of bus voltage and then press **>>** again to display the value of AI1.



Fig. 4-2 Stop parameter display status (Displaying setting frequency – 50.00Hz)

Running status would be enabled immediately upon the receipt of run command in stop status. Press **ENT** to get into parameter edit status (get into password authentication status if parameter under password protection). Directly get into frequency modification status when receive UP/DOWN command from terminal, or **▲** and **▼** pressing on Keypad. Switch to fault display status once a fault occurs or an alarm is given.

4.1.3.2 Running Parameters Display Status

In case there is no fault, drive will get into running parameters display status upon the receipt of run command. Default display is running frequency, and other parameters can be displayed through setting of L1-00 and L1-01 and press **>>** to shift. Example, in running status, when need to check bus voltage, motor speed, and input terminals status, we need to set L1-00=0084 and L1-01=0004, and press **>>** to shift to the display of bus voltage, then press **>>** again to display motor speed, and then press **>>** to display input terminals state value.



Fig. 4-3 Running parameter display status (Displaying running frequency – 50.00Hz)

Stop status would be enabled immediately upon the receipt of stop command in such a status. Press **ENT** to get into parameter edit status (get into password authentication status if parameter under password protection). Directly get into frequency modification status when receiving UP/DOWN command from terminal, or pressing **▲** or **▼**. Switch to fault alarm display status once a fault occurs or an alarm is given.

4.1.3.3 Fault Alarm Display Status

In case a fault occurs or an alarm is given, the drive will get into fault alarm display status.



Fig. 4-4 Fault alarm display status (CCL: coder disconnection fault)

In such a status, the drive gets into stop status upon the receipt of pressing **ENT**, and would get into parameter edit status when receiving pressing **ENT** command again (if parameter is under password protection, the drive would get into password authentication status). Directly get into frequency modification status when receive UP/DOWN command from terminal, or pressing **▲** or **▼**.

4.1.3.4 Parameter Edit Status

Enter parameter edit status immediately upon pressing **ENT** in STOP status, running parameters display status, and direct frequency modification status. This status could also be entered into upon receipt of consecutive twice pressing **ENT** in fault display status. The drive shall quit current status and be previous status upon the receipt of pressing **ESC**.



Fig. 4-5 Function code edit status

4.1.3.5 Parameter Setting Status

Enter parameter setting status upon the receipt of pressing **ENT** when in parameter edit status.

When pressing **ENT** or **ESC** command is received in such a state, escape function code edit status.



Fig. 4-6 Parameter setting status (b0-02 is set to 49.83Hz)

4.1.3.6 Password Authentication Status

On condition that parameters are under password protection, users would have to go through password authentication when they want to modify function code parameter value. Only A0-00 is visible in such a state.

Under password protection, the password authentication status would be first entered into upon the receipt of pressing **ENT** in STOP parameters display status, Running parameters display status, or direct frequency modification status (refer to setting method of parameters). Enter parameter edit status upon the completion of password authentication.

4.1.3.7 Direct Frequency Modification Status

In the status of STOP, fault or running, the drive will enter frequency modification status when terminal UP/DOWN is enabled, or pressing  or .



Fig. 4-7 Direct frequency modification status

4.1.3.8 Prompt Message Status

Prompt message status shall be displayed at the completion of some certain operations. For instance, the "bASIC" prompt message would be displayed upon the completion of parameter initialization.



Fig. 4-8 Prompt message status

Prompt message characters and their meanings are specified in Table 4-4.

Table 4-4 Prompt characters







































Prompt symbol	Meaning	Prompt symbol	Meaning
bASIC	When A0-01 is set to 0	CPyb1	Backup parameter value
dISP1	When A0-01 is set to 1	LoAd	Parameter upload to keypad
USEr	When A0-01 is set to 2	dnLd1	Parameter download from keypad (motor parameter excluded)
ndFLt	When A0-01 is set to 3	dnLd2	Parameter download from keypad (motor parameter included)
LoC-1	Keypad locked 1 (full locked)	P-SEt	Password has been set
LoC-2	Keypad locked 2 (all locked except RUN, STOP/RESET)	P-CLr	Password cleared
LoC-3	Keypad locked 3 (all locked except STOP/RESET)	TUNE	Motor parameter identification in process
LoC-4	Keypad locked 4 (all locked except shift )	LoU	Drive undervoltage
PrtCt	Keypad protection	CLr-F	Clear fault record
UnLoC	Keypad lock cleared	dEFt1	Restore to factory default parameters (motor parameter excluded)
rECy1	Read the backup parameter value to parameter	dEFt2	Restore to factory default parameters (motor parameter included)

Table 4-5 shows meanings of the characters displayed on Keypad.

Table 4-5 Meanings of displayed characters

Displayed character	Character Meaning	Displayed character	Character Meaning	Displayed character	Character Meaning	Displayed character	Character Meaning
	0		A		I		T
	1		b		J		t
	2		C		L		U
	3		c		N		u
	4		d		n		y
	5		E		o		-
	6		F		P		8.
	7		G		q		.
	8		H		r		
	9		h		S		

4.1.4 Setting Method of Parameters

4.1.4.1 Parameter System

Emotron VS series drive parameter group: A0 - A1, b0 - b2, C0 - C4, d0 - d5, E0 - E1, F0 - F3, H0, L0 - L1, U0 - U1. Each parameter group contains a number of parameters. Parameters are identified by the combination "parameter group character + parameter subgroup number + parameter number". For instance, "F3-07" indicates the seventh function code at subgroup 3, group F.

4.1.4.2 Parameter Display Structure

Parameters and the parameter values are subject to a two-tier structure. Parameters correspond to first-tier display, while parameter values correspond to second-tier display.

First-tier display shown in Fig. 4-9:



Fig. 4-9 First-tier display of parameter

Second-tier display shown in Fig. 4-10:



Fig. 4-10 Second-tier display of parameter ("3" is the value of b0-00)

4.1.4.3 Example of Setting of Parameter

Parameter values are divided into decimal (DEC) and hexadecimal (HEX) values. When a parameter value is expressed by a hexadecimal, all its digits are independent of each other during edition and the range of value would be (0 - F). (DEC)Parameter value is composed of the unit, decade, hundreds and kilo. Shift Key **>>** is used to select the digit to be changed, while **▲** and **▼** are used to increase or decrease numerical value.

Ø Example of parameter password setting

↳ Setting of password (A0-00 is set to 1006)

- 1) In non-parameter edit status, it displays current parameter A0-00 when pressing **ENT**.
- 2) Press **ENT** to display parameter value 0000 that belongs to A0-00;
- 3) Press **▲** for six times to change the rightmost digit "0" to "6";
- 4) Press **>>** to move the flashing digit to the leftmost bit;
- 5) Press **▲** once to change "0" in leftmost bit to "1";
- 6) Press **ENT** to save the value of A0-00, then Keypad will switch to display the next parameter A0-01;
- 7) Press **▼** to change A0-01 to A0-00;
- 8) Repeat steps 2) till 6). A0-01 will be displayed after keypad displaying P-SEt;
- 9) There are three methods for users to bring the password setting above into effect: Press **ESC + ENT + ▲** simultaneously (PrTcT displayed), don't operate keypad within 5 minutes, restart the drive.

Flow chart of user password setting:

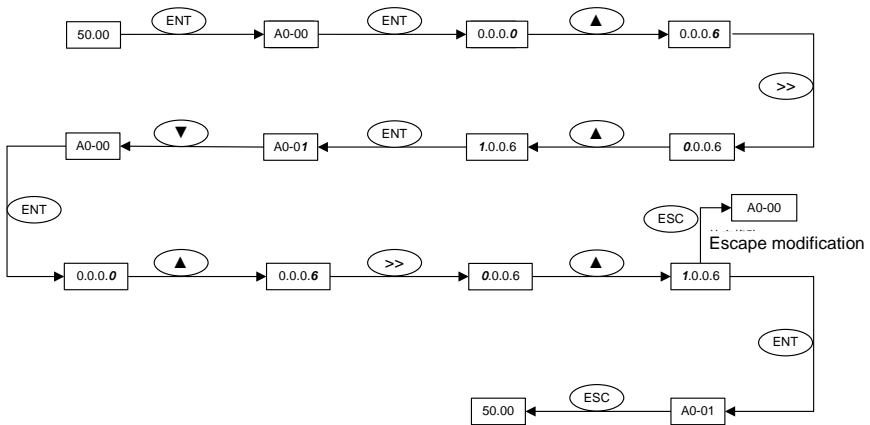

Fig. 4-11 Flow chart of user password setting

& ATTENTION:

User's password is successfully set when step 8 finished, but will not take effect until the completion of step 9.

⌋ Password authentication

In non-parameter edit status, press **ENT** to enter first-tier display A0-00, then press **ENT** to enter second-tier display 0.0.0.0. Keypad will implement the display of other parameters only when correct password entered.

⌋ Clear password

Upon the successful password authentication, access password setting code A0-00. Password can be cleared by writing value 0000 into A0-00 twice.

∅ Example of parameter setting

⌋ Example 1: modify upper limit frequency from 600Hz to 50Hz (change b0-09 from 600.00 to 50.00)

- 1) In non-parameter edit status, press **ENT** to display current parameter A0-00;
- 2) Press **>>** to move flashing digit to modification bit (A flashes);
- 3) Press **▲** once to change "A" to "b";
- 4) Press **>>** to move flashing to modification bit (0 in unit's place flashing);
- 5) Press **▲** nine times to change "0" to "9";
- 6) Press **ENT** to view the parameter value (600.00) of b0-09;
- 7) Press **>>** to move flashing digit to modification digit (6 flashing);
- 8) Press **▼** six times to change "6" to "0";
- 9) Press **>>** once to move flashing digit rightwards by one bit;
- 10) Press **▲** for five times to change "0" to "5";
- 11) Press **ENT** to save the value (50.00) of b0-09. Then the keypad will automatically switch to display the next function code (b0-10);
- 12) Press **ESC** to exit parameter edit status.

Flow chart is shown below:

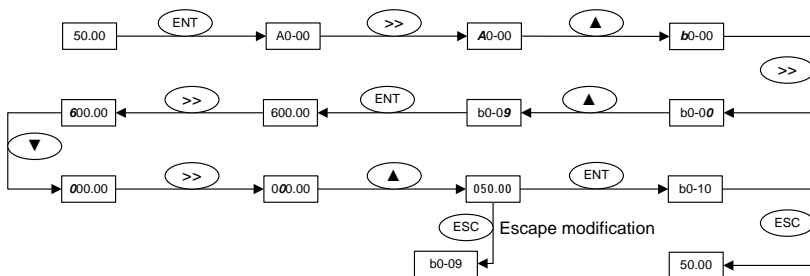

Fig. 4-12 Flow chart of upper limit frequency modification

U Example 2: user parameter initialization

- 1) In non-parameter edit status, press **ENT** to display current parameter A0-00;
- 2) Press **▲** three times to change "0" in the rightmost bit of A0-00 to "3";
- 3) Press **ENT** to display parameter value 0 of A0-03;
- 4) Press **▲** once to change "0" to "2" or "3" ("2" motor parameter excluded, "3" means motor parameter included);
- 5) Press **ENT** to save the value of A0-03. Then keypad will automatically display parameter A0-00;
- 6) Press **ESC** to escape parameter edit status.

Flow chart is shown below :

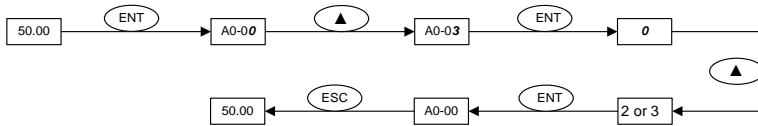

Fig. 4-13 Flow chart of user parameter initialization

□ Example 3: setting method of hexadecimal parameter

Take L1-02 (LED STOP display parameter) for example, if LED keypad is required to display: setting frequency, bus voltage, AI1, running linear speed, and setting linear speed. Since all bits are independent of each other, the unit's place, decade, hundreds place and thousands place should be set separately. Determine the binary numbers of each bit and then convert the binary numbers into a hexadecimal number. See Table 4-6, the corresponding relation between binary numbers and a hexadecimal number.

Table 4-6 Corresponding relation between binary and hexadecimal

Binary numbers				Hexadecimal (LED bit display value)
BIT3	BIT2	BIT1	BIT0	
0	0	0	0	0
0	0	0	1	1
0	0	1	0	2
0	0	1	1	3
0	1	0	0	4
0	1	0	1	5
0	1	1	0	6
0	1	1	1	7
1	0	0	0	8
1	0	0	1	9
1	0	1	0	A
1	0	1	1	B
1	1	0	0	C
1	1	0	1	D
1	1	1	0	E
1	1	1	1	F

Set the value in the unit's place:

As shown in Fig. 4-14, "setting frequency" and "bus voltage" are respectively determined by BIT0 and BIT1 in unit's place of L1-02. If BIT0=1, setting frequency would be displayed. The bits that correspond to the parameters which are not required to display shall be set to 0. Therefore, the value in unit's place should be 0011, corresponding to 3 in a hexadecimal number. Set the unit's place to 3.

Set the value in decade:

As shown in Fig. 4-14, since it is required to display "AI1", the binary set value of decade is 0001, corresponding to 1 in a hexadecimal number. Thus, bit of decade shall be set to 1.

Set the value in hundreds place:

As shown in Fig. 4-14, the parameter required to display does not involve hundreds place, so the hundreds place shall be set to zero.

Set thousand place:

As shown in Fig. 4-14, since required to display "running linear speed" and "setting linear speed", the binary set value of thousand place shall be 0011 that corresponds to 3 in a hexadecimal number.

To sum up, L1-02 should be set to 3013.

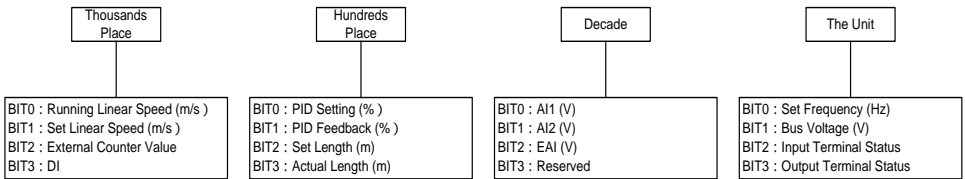

Fig. 4-14 Setting of hexadecimal parameter L1-02

Under parameter setting status, the parameter value cannot be modified if the value has no flashing digit. Possible causes include:

- 1) The parameter cannot be modified, such as actual detection parameters, running recording parameters, etc;
- 2) This parameter cannot be modified in running status but could be changed when motor stopped;
- 3) Parameter under protection. When parameter A0-02 is set to 1, parameters cannot be modified as the parameter protection against misoperation enabled. To edit parameter in such a circumstance, it is necessary to set A0-02 to 0 as first step.

4.1.4.4 Lock/Unlock Keypad

Ø Lock keypad

All or some keys of KEYPAD can be locked by any of the following three methods. See the definition of parameter L0-01 for further information.

Method 1: set the parameter value of L0-01 to non-zero, then press



Method 2: do not operate KEYPAD within five minutes after L0-01 is set to non-zero.

Method 3: cut the power off and then applying power on after L0-01 parameter is set to non-zero.

Refer to flow chart 4-15 for locking KEYPAD.

Ø Unlock keypad

To unlock keypad, press ESC + >> +, the Down arrow key simultaneously. Unlocking won't change the value of parameter L0-01. In other words, keypad will be locked again if the condition of locking keypad fulfilled. To unlock keypad completely, L0-01 value must be modified to 0 after momentary unlocked.

Refer to flow chart 4- 16 of unlocking keypad

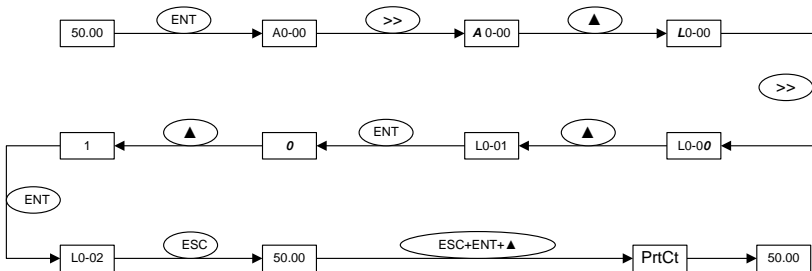

Fig. 4-15 Flow chart of locking keypad



Fig. 4-16 Flow chart of unlocking keypad

4.2 Initial Power up

Perform wiring in strict accordance with technical requirements as set forth in Chapter 3 - Installation and Wiring. Flow chart of Initial power up is shown below:

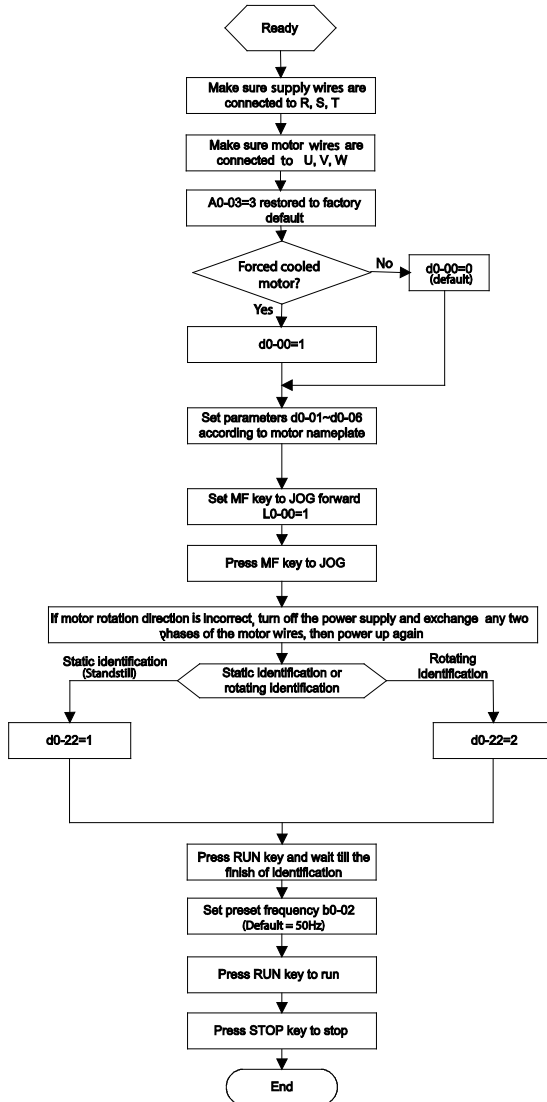

Fig. 4-17 Flow chart of initial power up for asynchronous motor

4.2.1 Examples for Quick setup

The following are examples for Quick setup with wiring and parameter settings. For more detailed information, see the main instruction manual "Chapter 6 Specification of parameters".

4.2.1.1 Analogue speed reference 0-10V to AI1

1. Set Signal switch S2 to V see chapter 3.10 Instruction of Signal Switches.
2. Connect analogue reference signal + to AI1 and - to GND. If manual potentiometer (10kOhm) is used connect the mid point to AI1 and ends to +10V and GND. see Fig 4.18.
3. Connect start signals: RunFWD to DigitalIn1 and Run REV to DigitalIn2. If none or both DigIn1 and DigIn2 are activated = Stop

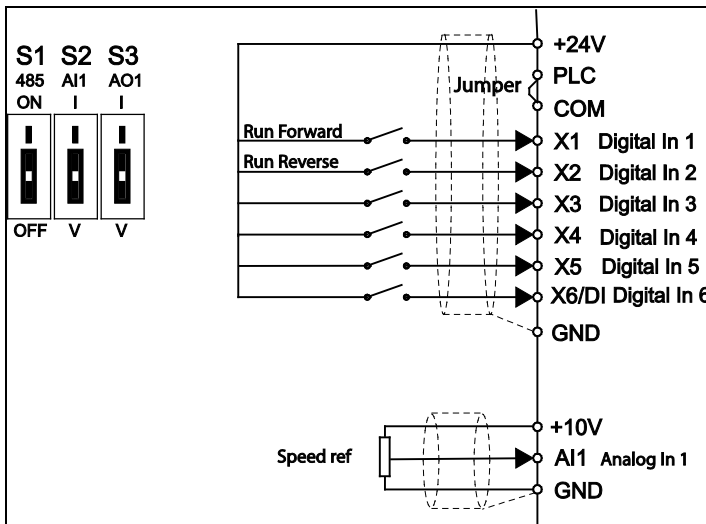

Fig 4-18 Connect pot. to +10V, GND and AI1 terminal

Application parameter settings as below.

Table 4-7

Parameter	Designation	Set Value	Comment
b0-01	Master frequency reference source	2: AI1	
b0-08	Maximum frequency	set value	50Hz *
b0-10	Minimum frequency	set value	0Hz *
b1-00	Run command source	1: Terminal control	Digital inputs
b2-01	Acceleration time 1	set value	6s *
b2-02	Deceleration time 1	set value	6s *
C0-01	Digital input X1 function	3: FWD	
C0-02	Digital input X2 function	4: REV	
C2-00	Analogue input curve	000 *	AI1 curve 1 (2 point curve)
C2-01	Maximum input of curve 1	100% *	
C2-02	Set value(reference) corresponding to maximum input of curve 1	100% *	
C2-03	Minimum input of curve 1	0% *	
C2-04	Set value (reference) corresponding to minimum input of curve 1	0% *	

* = default value

4.2.1.2 Analogue speed reference +/-10V to AI2

1. Connect analogue reference signal: + to AI2 and - to GND.
2. Connect start signals: Run FWD to DigitalIn1 and Run REV to DigitalIn2. If none or both Dign1 and Dign2 are activated = Stop.

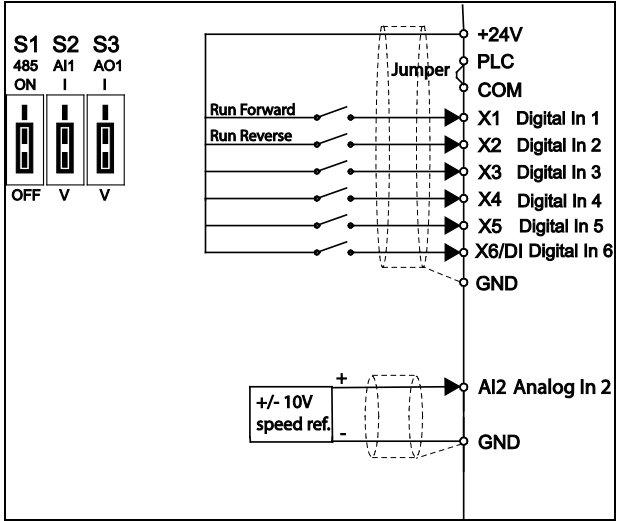

Fig: 4-19 Connect analogue reference signal + to AI2 and - to GND

Application parameter settings

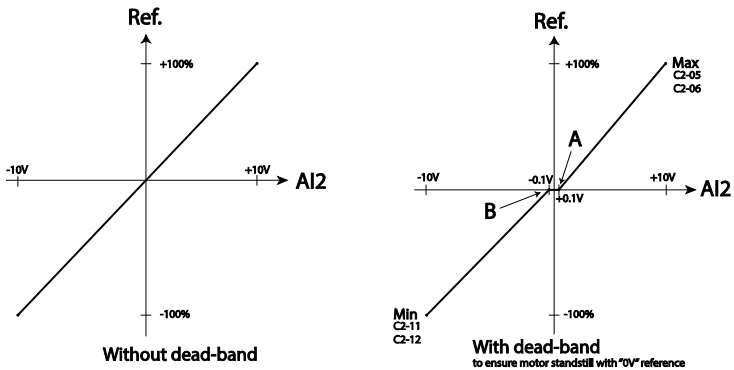

Fig 4-20 Analogue input curve without or with dead-band.

Table 4-8

Parameter	Designation	Alternative 1 setting without dead-band	Alternative 2 setting with dead-band	Comment
b0-01	Master frequency reference source	3: AI2		
b0-08	Maximum frequency	set value		50Hz *
b0-10	Minimum frequency	set value		0Hz *
b1-00	Run command source	1: Terminal control	1: Terminal control	Digital inputs
b2-01	Acceleration time 1	set value		6s *
b2-02	Deceleration time 1	set value		6s *
C0-01	Digital input X1 function	3: FWD		
C0-02	Digital input X2 function	4: REV		
C2-00	Analogue input curve	000 * ; AI1 curve 1 (2 points)	010:AI2 curve 2 (4 points)	Without or with dead band
C2-01	Maximum input of curve 1	100% *	100% *	
C2-02	Set value (reference) corresponding to maximum input of curve 1	100% *	N.A.	
C2-03	Minimum input of curve 1	-100%	N.A.	

C2-04	Set value (reference) corresponding to minimum input of curve 1	-100%	N.A.	
C2-05	Maximum input of curve 2	N.A.	100%	
C2-06	Set value corresponding to maximum input of curve 2	N.A.	100%	
C2-07	Input of inflection point A of curve 2	N.A.	1%	Equal to 0.1V with 10V max
C2-08	Set value (reference) corresponding to Input of inflection point A of curve 2	N.A.	0%	
C2-11	Minimum input of curve 2	N.A.	-100%	
C2-12	Set value corresponding to minimum input of curve 2	N.A.	-100%	
C2-09	Input of inflection point B of curve 2	N.A.	-1%	Equal to - 0.1V with 10V max
C2-10	Set value (reference) corresponding to Input of inflection point B of curve 2	N.A.	0%	

* = default value

4.2.1.3 Analogue speed reference 4-20 mA to AI1

1. Set Signal switch S2 to I, see chapter 3.10 Instruction of Signal Switches.
2. Connect analogue reference signal: + to AI1 and - to GND
3. Connect start signals: Run FWD to DigitalIn1 and Run REV to DigitalIn2. If none or both DigIn1 and DigIn2 are activated = Stop.

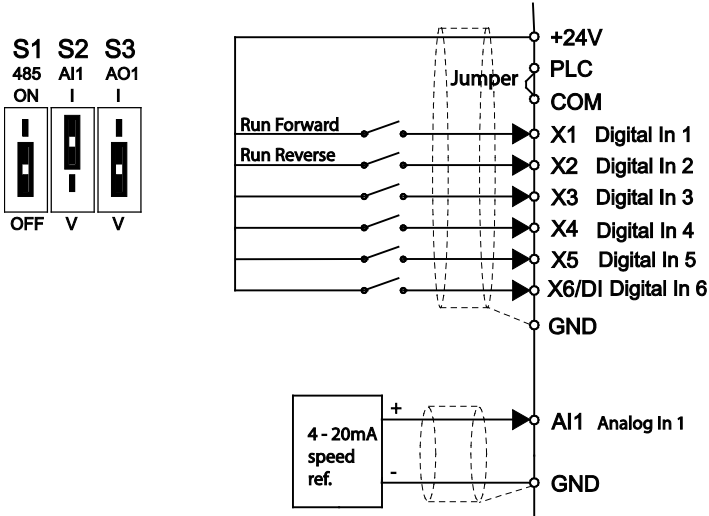

Fig 4-21. Connection for Analogue speed reference 4-20mA to AI1

Application parameter settings as below.

Table 4-9

Parameter	Designation	Set Value	Comment
b0-01	Master frequency reference source	2: AI1	
b0-08	Maximum frequency	set value	50Hz *
b0-10	Minimum frequency	set value	0Hz *
b1-00	Run command source	1: Terminal control	Digital inputs
b2-01	Acceleration time 1	set value	6s *
b2-02	Deceleration time 1	set value	6s *
C0-01	Digital input X1 function	3: FWD	
C0-02	Digital input X2 function	4: REV	
C2-00	Analogue input curve	000 *	AI1 curve 1 (2 point curve)
C2-01	Maximum input of curve 1	100% *	20mA
C2-02	Set value corresponding to maximum input of curve 1	100% *	
C2-03	Minimum input of curve 1	20% *	=4/20
C2-04	Set value corresponding to minimum input of curve 1	0% *	

* = default value

4.2.1.4 4 preset speeds, Start/Stop and Reverse by Digital Inputs

1. Connect the jumper between PLC and COM if not already connected.
2. Connect RUN contact SB2 between +24V and Digital Input 1.
3. Connect REVERSE selection contact between +24V and Digital Input 2.
4. Connect STOP contact SB1 (STOP when open) between +24V and Digital Input 3.
5. Connect Preset bit0 contact between +24V and Digital Input 4.
6. Connect Preset bit1 contact between +24V and Digital Input 5.

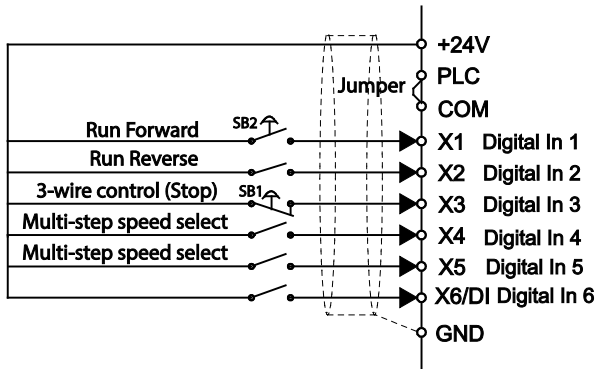

Fig. 4-21. Connection for 4 preset speeds start/stop and reverse by DI

Application parameter settings as below.

Table 4-10

Parameter	Designation	Set Value	Comment
b0-01	Master frequency reference source	8: Multi-step speed	Preset speeds
b0-08	Maximum frequency	set value	50Hz *
b0-10	Minimum frequency	set value	0Hz *
b1-00	Run command source	1: Terminal control	Digital inputs
b2-01	Acceleration time 1	set value	6s *
b2-02	Deceleration time 1	set value	6s *
C0-01	Digital input X1 function	3: FWD	Start button SB2
C0-02	Digital input X2 function	4: REW	Reverse direction
C0-03	Digital input X3 function	5: 3-wire control	Stop button SB1
C0-04	Digital input X4 function	15:Multi-step	Bit 0, speed selection
C0-05	Digital input X5 function	16:Multi-step	Bit 1, speed selection
C0-19	FWD/REV terminal control mode	3: Three-wire mode 2	
F1-00	Source for Preset frequency 0	0*: Digital setting F1-02	
F1-01	Source for Preset frequency 1	0*: Digital setting F1-03	
F1-02	Preset frequency 0	Set <Speed 0>	Bit1=0, Bit0=0
F1-03	Preset frequency 1	Set <Speed 1>	Bit1=0, Bit0=1
F1-04	Preset frequency 2	Set <Speed 2>	Bit1=1, Bit0=0
F1-05	Preset frequency 3	Set <Speed 3>	Bit1=1, Bit0=1

* = default value

Chapter 5 List of Parameters

Emotron VS parameter groups are listed below:

Category	Parameter group	Reference page
Group A: system parameter and parameter management	A0: system parameters	P71; P112
	A1: user-defined displayed parameters	P72; P115
Group b: setting of running parameters	b0: frequency command	P73; P117
	b1: start/stop control	P75; P131
	b2: Accel/Decel parameters	P77; P136
Group C: input and output terminals	C0: digital input	P78; P143
	C1: digital output	P80; P157
	C2: analogue and pulse input	P82; P164
	C3: analogue and pulse output	P83; P170
	C4: automatic correction of analogue input	P84; P174
Group d: motor and control parameters	d0: parameters of motor 1	P85; P176
	d1: V/f control parameters of motor 1	P86; P180
	d2: vector control parameters of motor 1	P87; P187
	d3: parameters of motor 2	P88; P191
	d4: V/f control parameters of motor 2	P90; P193
	d5: vector control parameter of motor 2	P91; P194
Group E: enhancement function and protection parameters	E0: enhancement function	P92; P195
	E1: protection parameters	P93; P199
Group F: application	F0: process PID	P95; P203
	F1: multi-step frequency	P96; P209
	F2: simple PLC	P97; P212
	F3: wobble frequency and fixed length count	P101; P221
Group H: communication parameters	H0: MODBUS communication parameters	P102; P225
Group L: keys and display of keypad	L0: keys of keypad	P103; P227
	L1: LED display setting	P103; P228
Group U: monitoring	U0: status monitoring	P105; P231
	U1: fault record	P108; P235

& ATTENTION:

Change attribute:

" " means the value of this parameter can be modified in stop and running status of drive;

"x" means the value of this parameter cannot be modified when drive is running;

" " means this parameter is a measured value that cannot be modified;

Factory default value: The value when restored to factory default. Neither measured parameter value nor recorded value will be restored.

Scope: the scope of setting and display of parameters

Parameter	Designation	Scope	Factory default	Attr
Group A: System Parameter and Parameter Management				
Group A0: System Parameter				
A0-00	Setting of user password	0 - FFFF	0000	
A0-01	Display of parameters	0: Display all parameters 1: Only display parameters A0-00 and A0-01 2: Only display A0-00, A0-01 and user-defined parameters A1-00 to A1-19 3: Only display A0-00, A0-01, and the parameters different with factory default	0	
A0-02	Parameter protection	0: All parameter programming allowed 1: Only A0-00 and this parameter programming allowed	0	x
A0-03	Parameter initialization	0: No operation 1: Clear fault record 2: Restore all parameters to factory default (excluding motor parameters) 3: Restore all parameters to factory default (including motor parameters) 4: Restore all parameters to backup parameters	0	x
A0-04	Parameter backup	0: No operation 1: Backup all parameters	0	x
A0-05	Copy of parameters	0: No operation	0	x

Parameter	Designation	Scope	Factory default	Attr
		1: Parameter upload 2: Parameter download (excluding motor parameters) 3: Parameter download (including motor parameters)		
A0-06	Type of drive	0: Type G (applicable to constant-torque load) 1: Type L (applicable to light-duty load)	0	×
A0-07	Power supply type of the drive	0: AC input 1: DC input	0	×
A0-08	Selection of motor 1/motor 2	0: Motor 1 1: Motor 2	0	×
A0-09	Motor control technique	Unit's place: control technique of motor 1 0: V/f control 1: Sensor-less vector control 1 2: Sensor-less vector control 2 Decade: control technique of motor 2 0: V/f control 1: Sensor-less vector control 1 2: Sensor-less vector control 2	00	×
Group A1: User-defined Displayed Parameters				
A1-00	User-defined displayed parameter 1	Setting range of thousands place: 0, A, b, C, d, E, F, H, L, U Setting range of hundreds place: 0 - 9 Setting range of decade: 0 - 9 Setting range of unit's place: 0 - 9	A0-00	×
A1-01	User-defined displayed parameter 2		A0-00	×
A1-02	User-defined displayed parameter 3		A0-00	×
A1-03	User-defined display parameter 4		A0-00	×
A1-04	User-defined displayed parameter 5		A0-00	×
A1-05	User-defined displayed parameter 6		A0-00	×
A1-06	User-defined displayed parameter 7		A0-00	×
A1-07	User-defined displayed parameter 8		A0-00	×
A1-08	User-defined displayed parameter 9		A0-00	×
A1-09	User-defined displayed parameter		A0-00	×

Parameter	Designation	Scope	Factory default	Attr
	parameter 10			
A1-10	User-defined displayed parameter 11		A0-00	×
A1-11	User-defined displayed parameter 12		A0-00	×
A1-12	User-defined displayed parameter 13		A0-00	×
A1-13	User-defined displayed parameter 14		A0-00	×
A1-14	User-defined displayed parameter 15		A0-00	×
A1-15	User-defined displayed parameter 16		A0-00	×
A1-16	User-defined displayed parameter 17		A0-00	×
A1-17	User-defined displayed parameter 18		A0-00	×
A1-18	User-defined displayed parameter 19		A0-00	×
A1-19	User-defined displayed parameter 20		A0-00	×
A1-20	Parameter group display/hide characteristic 1	0 - FFFF	FFFF	×
A1-21	Parameter group display/hide characteristic 2	0 - FFFF	FFFF	×
Group b Setting of Running Parameters				
Group b0 Frequency Command				
b0-00	Frequency command pattern	0: Master frequency command 1: Master & auxiliary computation result 2: Switch between master and auxiliary command 3: Switch between master frequency command, and master & auxiliary computation result 4: Switch between auxiliary frequency command, and master & auxiliary computation result	0	×
b0-01	Master frequency command source	0: Digital setting (b0-02) + \wedge / \vee adjustment on keypad 1: Digital setting (b0-02) + terminal	0	×

Parameter	Designation	Scope	Factory default	Attr
		UP/DOWN adjustment 2: Analogue input AI1 3: Analogue input AI2 4: Analogue input EAI (on IO expansion board) 5: X6/DI pulse input 6: Process PID output 7: PLC 8: Multi-step speed 9: Communication		
b0-02	Digital setting of master frequency	Lower limit frequency to upper limit frequency	50.00Hz	
b0-03	Auxiliary frequency command source	0: No command 1: Digital setting (b0-04) + \wedge / \vee adjustment on keypad 2: Digital setting (b0-04) + terminal UP/DOWN adjustment 3: Analogue input AI1 4: Analogue input AI2 5: Analogue input EAI (on IO expansion board) 6: X6/DI pulse input 7: Process PID output 8: PLC 9: Multi-step speed 10: Communication	0	x
b0-04	Digital setting of auxiliary frequency	Lower limit frequency to upper limit frequency	0.00Hz	
b0-05	Range of auxiliary frequency	0: Relative to maximum frequency 1: Relative to master frequency	0	x
b0-06	Coeff of auxiliary frequency	0.0% - 100.0%	100.0%	x
b0-07	Computation of master and auxiliary frequency	0: Master + auxiliary 1: Master - auxiliary 2: Max {master, auxiliary} 3: Min {master, auxiliary}	0	x
b0-08	Maximum frequency	Upper limit frequency - 600.00Hz	50.00Hz	x
b0-09	Upper limit frequency	Lower limit frequency - maximum frequency	50.00Hz	x
b0-10	Lower limit frequency	0.00Hz - upper limit frequency	0.00Hz	x
b0-11	Operation when command frequency lower than lower limit frequency	0: Run at lower limit frequency 1: Run at 0 Hz 2: Stop	0	x

Parameter	Designation	Scope	Factory default	Attr
b0-12	Time-delay of stop when command frequency lower than lower limit frequency	0.0s - 6553.5s	0.0s	×
b0-13	Lower limit of skip frequency band 1	0.00Hz - upper limit frequency	0.00Hz	×
b0-14	Upper limit of skip frequency band 1	0.00Hz - upper limit frequency	0.00Hz	×
b0-15	Lower limit of skip frequency band 2	0.00Hz - upper limit frequency	0.00Hz	×
b0-16	Upper limit of skip frequency band 2	0.00Hz - upper limit frequency	0.00Hz	×
b0-17	Lower limit of skip frequency band 3	0.00Hz - upper limit frequency	0.00Hz	×
b0-18	Upper limit of skip frequency band 3	0.00Hz - upper limit frequency	0.00Hz	×
b0-19	Jog frequency	0.00Hz - upper limit frequency	5.00Hz	
Group b1 Start/Stop Control				
b1-00	Run command	0: Keypad control 1: Terminal control 2: Communication control	0	×
b1-01	Binding of run command and frequency command	Unit's place: frequency command source bundled under keypad control: 0: No binding 1: Digital setting (b0-02) + \wedge / \vee adjustment on keypad 2: Digital setting (b0-02) + terminal UP/DOWN adjustment 3: Analogue input AI1 4: Analogue input AI2 5: Analogue input EAI (on IO expansion board) 6: X6/DI pulse input 7: Process PID output 8: Simple PLC 9: Multi-step frequency A: Communication input Decade: frequency command source bundled under terminal control (same as unit's place) Hundreds place: frequency command source bundled under	000	×

Parameter	Designation	Scope	Factory default	Attr
		communication control (same as unit's place)		
b1-02	Running direction	0: Forward 1: Reverse	0	
b1-03	Reverse disabled	0: Reverse enabled 1: Reverse disabled	0	×
b1-04	Dead time of forward and reverse	0.0s - 3600.0s	0.0s	
b1-05	Start method	0: From start frequency 1: DC braking then start 2: Start based on speed search	0	×
b1-06	Start frequency	0.00Hz - upper limit frequency	0.00Hz	×
b1-07	Holding time of start frequency	0.0s - 3600.0s	0.0s	
b1-08	DC braking current when start	0.0% - 100.0%	0.0%	
b1-09	DC braking time when start	0.00s - 30.00s	0.00s	
b1-10	Speed search current	0.0 - 200.0%	100.0%	×
b1-11	Speed search Decel time	0.1s - 20.0s	2.0s	×
b1-12	V/f coefficient during speed search	20.0 - 100.0%	100.0%	×
b1-13	Stop method	0: Ramp to stop 1: Coast to stop 2: Ramp to stop + DC brake	0	×
b1-14	Start frequency of DC brake stop	0.00Hz - upper limit frequency	0.00Hz	×
b1-15	Brake current	0.0% - 100.0%	0.0%	
b1-16	Brake time	0.00s - 30.00s	0.00s	
b1-17	Overexcitation brake	0: Disabled 1: Enabled	1	×
b1-18	Dynamic brake	0: Disabled 1: Enabled	0	×
b1-19	Dynamic brake threshold voltage	650V - 750V	720V	×
b1-20	Auto restart when power up again after power loss	0: Disabled 1: Enabled	0	×
b1-21	Waiting time of auto restart when power up again	0.0s - 10.0s	0.0s	

Group b2 Accel/Decel Parameters				
b2-00	Accel/Decel time resolution	0:0.01s 1:0.1s 2:1s	1	x
b2-01	Accel time 1	0s - 600.00s/6000.0s/60000s	6.0s	
b2-02	Decel time 1	0s - 600.00s/6000.0s/60000s	6.0s	
b2-03	Accel time 2	0s - 600.00s/6000.0s/60000s	6.0s	
b2-04	Decel time 2	0s - 600.00s/6000.0s/60000s	6.0s	
b2-05	Accel time 3	0s - 600.00s/6000.0s/60000s	6.0s	
b2-06	Decel time 3	0s - 600.00s/6000.0s/60000s	6.0s	
b2-07	Accel time 4	0s - 600.00s/6000.0s/60000s	6.0s	
b2-08	Decel time 4	0s - 600.00s/6000.0s/60000s	6.0s	
b2-09	Decel time when emergency stop enabled	0s - 600.00s/6000.0s/60000s	6.0s	
b2-10	Jog Accel time	0s - 600.00s/6000.0s/60000s	6.0s	
b2-11	Jog Decel time	0s - 600.00s/6000.0s/60000s	6.0s	
b2-12	Accel/Decel curve	0: Linear Accel/Decel 1: Broken-line Accel/Decel 2: S-curve Accel/Decel A 3: S-curve Accel/Decel B 4: S-curve Accel/Decel C	0	x
b2-13	Accel time switching frequency of broken-line Accel/Decel	0.00Hz - maximum frequency	0.00Hz	
b2-14	Decel time switching frequency of broken-line Accel/Decel	0.00Hz - maximum frequency	0.00Hz	
b2-15	Time of initial segment of Accel S-curve	0.00s - 60.00s (S-curve A)	0.20s	Δ
b2-16	Time of last segment of Accel S-curve	0.00s - 60.00s (S-curve A)	0.20s	Δ
b2-17	Time of initial segment of Decel S-curve	0.00s - 60.00s (S-curve A)	0.20s	Δ
b2-18	Time of last segment of Decel S-curve	0.00s - 60.00s (S-curve A)	0.20s	Δ
b2-19	Proportion of initial segment of Accel S-curve	0.0% - 100.0% (S-curve B)	20.0%	Δ
b2-20	Proportion of last segment of Accel S-curve	0.0% - 100.0% (S-curve B)	20.0%	Δ
b2-21	Proportion of initial segment of Decel S-curve	0.0% - 100.0% (S-curve B)	20.0%	Δ

b2-22	Proportion of last segment of Decel S-curve	0.0% - 100.0% (S-curve B)	20.0%	Δ
Group C Input and Output Terminals				
Group C0 Digital Input				
C0-00	Enabled condition of run command terminals when power up	0: Trigger edge detected + ON detected 1: ON detected	0	×
C0-01	Function of terminal X1	0: No function 1: JOG forward	0	×
C0-02	Function of terminal X2	2: JOG reverse 3: Running forward (FWD)	0	×
C0-03	Function of terminal X3	4: Running reverse (REV) 5: Three-wire control	0	×
C0-04	Function of terminal X4	6: Running suspended 7: External stop	0	×
C0-05	Function of terminal X5	8: Emergency stop 9: Stop command + DC brake	0	×
C0-06	Function of terminal X6/DI	10: DC brake stop 11: Coast to stop	0	×
C0-07	Function of terminal EX (on IO expansion board)	12: Terminal UP 13: Terminal DOWN	0	×
C0-08	Function of terminal AI1 (Digital enabled)	14: UP/DOWN (including / key) adjustment clear	0	×
C0-09	Function of terminal AI2 (Digital enabled)	15: Multi-step frequency terminal 1 16: Multi-step frequency terminal 2 17: Multi-step frequency terminal 3 18: Multi-step frequency terminal 4 19: Accel/Decel time determinant 1 20: Accel/Decel time determinant 2	0	×
C0-10	Function of terminal EAI (Digital enabled) (on IO expansion board)	21: Accel/Decel disabled(ramp stop not inclusive) 22: External fault input 23: Fault reset (RESET) 24: Pulse input (valid only for X6/DI) 25: Motor 1/2 switchover 26: Reserved 27: Run command switched to keypad control 28: Run command switched to terminal control 29: Run command switched to communication control 30: Frequency command pattern shift 31: Master frequency command	0	×

		switched to digital setting b0-02 32: Auxiliary frequency command switched to digital setting b0-04 33: PID adjustment direction 34: PID paused 35: PID integration paused 36: PID parameter switch 37: Count input 38: Count clear 39: Length count 40: Length clear 41 - 62: Reserved 63: Simple PLC paused 64: Simple PLC disabled 65: Simple PLC stop memory clear 66: Start wobble frequency 67: Clear wobble frequency status 68: Running prohibited 69: DC brake in running 70 - 99: Reserved		
C0-11	Filtering time of digital input terminal	0.000s - 1.000s	0.010s	Δ
C0-12	Delay time of terminal X1	0.0s - 3600.0s	0.0s	Δ
C0-13	Delay time of terminal X2	0.0s - 3600.0s	0.0s	Δ
C0-14	Digital input terminal enabled status setting 1	Unit's place: X1 0: Positive logic 1: Negative logic Decade: X2 (same as unit's place) Hundreds place: X3 (same as unit's place) Thousands place: X4 (same as unit's place)	0000	×
C0-15	Digital input terminal enabled status setting 2	Unit's place: X5 0: Positive logic 1: Negative logic Decade: X6 (valid as ordinary terminal, same as unit's place) Hundreds place (on IO expansion board, same as unit's place) Thousands place: reserved	0000	×
C0-16	Digital input terminal enabled status setting 3	Unit's place: A11 0: Positive logic 1: Negative logic Decade: A12 (same as unit's place)	0000	×

		Hundreds place: EAI (on IO expansion board, same as unit's place) Thousands place: reserved		
C0-17	Terminal UP/DOWN frequency adjustment treatment	Unit's place: action when stop 0: Clear 1: Holding Decade: action on power loss 0: Clear 1: Holding Hundreds place: integral function 0: No integral function 1: Integral function enabled	0000	Δ
C0-18	Terminal UP/DOWN frequency change step size	0.00Hz/s - 100.00Hz/s	0.03Hz/s	Δ
C0-19	FWD/REV terminal control mode	0: Two-wire mode 1 1: Two-wire mode 2 2: Three-wire mode 1 3: Three-wire mode 2	0	×
C0-20	Option of virtual input terminal	000 - 77F 0: Actual terminal in effect 1: Virtual terminal in effect Unit's place: BIT0 - BIT3: X1 - X4 Decade: BIT4 - BIT6: X5 - X6, EX Hundreds place: BIT8 - BIT10: AI1 - AI2, EAI (EX and EAI on IO expansion board)	000	×
Group C1 Digital Output				
C1-00	Y1 output function	0: No output	0	Δ
C1-01	Y2/DO output function (when used as Y2)	1: Drive undervoltage 2: Drive running preparation	0	Δ
C1-02	Control board relay output function	completed 3: Drive is running	14	Δ
C1-03	Expansion board relay output function	4: Drive in 0Hz running (no output at stop) 5: Drive in 0Hz running (output at stop) 6: Running direction 7: Frequency attained 8: Upper limit frequency attained 9: Lower limit frequency attained 10: Frequency higher than FDT 1 11: Frequency higher than FDT 2	15	Δ

		12: Reserved 13: Torque limited 14: Fault output 15: Alarm output 16: Drive (motor) overloaded alarm 17: Drive thermal alarm 18: Zero current detection 19: X1 20: X2 21: Motor 1/ 2 indication 22: Set count value attained 23: Designated count value attained 24: Length attained 25: Consecutive running time attained 26: Accumulative running time attained 27: Contracting brake control 28: Reserved 29: Reserved 30: PLC step completed 31: PLC cycle completed 32: Wobble frequency attains to upper or lower limit frequency 33 - 99: Reserved		
C1-04	Y1 output delay time	0.0s - 3600.0s	0.0s	Δ
C1-05	Y2 output delay time	0.0s - 3600.0s	0.0s	Δ
C1-06	Control board relay output delay time	0.0s - 3600.0s	0.0s	Δ
C1-07	Expansion board relay output delay time	0.0s - 3600.0s	0.0s	Δ
C1-08	Enabled state of digital output	Unit's place: Y1 0: Positive logic 1: Negative logic Decade: Y2 (same as unit's place) Hundreds place: control board relay output (same as unit's place) Thousands place: expansion board relay output (same as unit's place)	0000	×
C1-09	Detective object of frequency doubling technology(FDT)	Unit's place: FDT1 detective object 0: Set value of speed (frequency after Accel/Decel) 1: Detected speed value Decade: FDT2 detective object	00	Δ

		0: Set value of speed (frequency after Accel/Decel) 1: Detected speed value		
C1-10	FDT1 upper bound	0.00Hz - maximum frequency	50.00Hz	Δ
C1-11	FDT1 lower bound	0.00Hz - maximum frequency	49.00Hz	Δ
C1-12	FDT2 upper bound	0.00Hz - maximum frequency	25.00Hz	Δ
C1-13	FDT2 lower bound	0.00Hz - maximum frequency	24.00Hz	Δ
C1-14	Detection width of frequency attained	0.00Hz - maximum frequency	2.50Hz	Δ
C1-15	Zero current detection level	0.0% - 50.0%	5.0%	Δ
C1-16	Zero current detection time	0.01s - 50.00s	0.50s	Δ
Group C2 Analogue and Pulse Input				
C2-00	Analogue input curve	Unit's place: AI1 input curve 0: Curve 1 (2 points) 1: Curve 2 (4 points) 2: Curve 3 (4 points) Decade: AI2 input curve (same as unit's place) Hundreds place: EAI input curve (same as unit's place) Thousands place: reserved	000	×
C2-01	Maximum input of curve 1	Minimum input of curve 1 - 110.0%	100.0%	×
C2-02	Corresponding set value of maximum input of curve 1	-100.0% to 100.0%	100.0%	×
C2-03	Minimum input of curve 1	-110.0% to maximum input of curve 1	0.0%	×
C2-04	Corresponding set value of minimum input of curve 1	-100.0% to 100.0%	0.0%	×
C2-05	Maximum input of curve 2	Range: input of inflection point A of curve 2 - 110.0%	100.0%	×
C2-06	Set value corresponding to maximum input of curve 2	Range: -100.0% to 100.0%	100.0%	×
C2-07	Input of inflection point A of curve 2	Input of inflection point B of curve 2 - maximum input of curve 2	0.0%	×
C2-08	Set value corresponding to input of inflection point A of curve 2	Range: -100.0% to 100.0%	0.0%	×
C2-09	Input of inflection point B of curve 2	Range: Minimum input of curve 2 - Input of inflection point A of curve 2	0.0%	×
C2-10	Set value corresponding to	Range: -100.0% to 100.0%	0.0%	×

	input of inflection point B of curve 2			
C2-11	Minimum input of curve 2	Range: -110.0% to input of inflection point B of curve 2	0.0%	×
C2-12	Set value corresponding to minimum input of curve 2	Range: -100.0% to 100.0%	0.0%	×
C2-13	Maximum input of curve 3	Range: input of inflection point A of curve 3 - 110.0%	100.0%	×
C2-14	Set value corresponding to maximum input of curve 3	Range: -100.0% to 100.0%	100.0%	×
C2-15	Input of inflection point A of curve 3	Range: input of inflection point B of curve 3 - maximum input of curve 3	0.0%	×
C2-16	Set value corresponding to input of inflection point A of curve 3	Range: -100.0% to 100.0%	0.0%	×
C2-17	Input of inflection point B of curve 3	Range: minimum input of curve 3 - input of inflection point A of curve 3	0.0%	×
C2-18	Set value corresponding to input of inflection point B of curve 3	Range: -100.0% to 100.0%	0.0%	×
C2-19	Minimum input of curve 3	Range: -110.0% to input of inflection point B of curve 3	0.0%	×
C2-20	Set value corresponding to minimum input of curve 3	Range: -100.0% to 100.0%	0.0%	×
C2-21	AI1 terminal filtering time	0.000s - 10.000s	0.01s	Δ
C2-22	AI2 terminal filtering time	0.000s - 10.000s	0.01s	Δ
C2-23	EAI terminal filtering time (on IO expansion board)	0.000s - 10.000s	0.01s	Δ
C2-24	DI maximum input	Range: C2-26 to 50.0kHz	50.0kHz	×
C2-25	Set value corresponding to DI maximum input	Range: -100.0% to 100.0%	100.0%	×
C2-26	DI minimum input	Range: 0.0kHz - C2-24	0.0kHz	×
C2-27	Set value corresponding to DI minimum input	Range: -100.0% to 100.0%	0.0%	×
C2-28	DI filtering time	0.000s - 1.000s	0.001s	Δ
C2-29	Interrupt detection time	Range: 0.00s - 100.00s	0.50s	Δ
Group C3 Analogue and Pulse Output				
C3-00	AO1 output function	0: No output	2	Δ
C3-01	EAO output function (on IO expansion board)	1: Command frequency 2: Output frequency	1	Δ

C3-02	Y2/DO output function (when used as DO)	3: Output current 4: Output torque 5: Output voltage 6: Output power 7: Bus voltage 8: Reserved 9: Torque current 10: Magnetic flux current 11:AI1 12:AI2 13:EAI 14: Reserved 15:DI 16:Communication input percentage 17: Output frequency before compensation 18 - 99: Reserved	2	Δ
C3-03	AO1 offset	-100.0% to 100.0%	0.0%	×
C3-04	AO1 gain	-2.000 to 2.000	1.000	×
C3-05	AO1 filtering time	0.0s - 10.0s	0.0s	Δ
C3-06	EAO offset	-100.0% to 100.0%	0.0%	×
C3-07	EAO gain	-2.000 to 2.000	1.000	×
C3-08	EAO filtering time	0.0s - 10.0s	0.0s	Δ
C3-09	DO maximum output pulse frequency	0.1kHz - 50.0kHz	50.0kHz	Δ
C3-10	DO output center point	0: No center point 1: Center point is (C3-09)/2, and the corresponding parameter value is positive when frequency is higher than center point 2: Center point is (C3-09)/2, and the corresponding parameter value is positive when frequency is lower than center point	0	×
C3-11	DO output filtering time	0.00s - 10.00s	0.01s	Δ
Group C4 Automatic Correction of Analogue Input				
C4-00	Analogue corrected channel	0: No correction 1:Correct AI1 2:Correct AI2 3:Correct EAI	0	×
C4-01	Sampling value of calibration point 1 of AI1	Range: 0.00V - 10.00V	1.00V	
C4-02	Input value of calibration	Range: 0.00V - 10.00V	1.00V	×

	point 1 of AI1			
C4-03	Sampling value of calibration point 2 of AI1	Range: 0.00V - 10.00V	9.00V	
C4-04	Input value of calibration point 2 of AI1	Range: 0.00V - 10.00V	9.00V	×
C4-05	Sampling value of calibration point 1 of AI2	Range: -10.00V to 10.00V	1.00V	
C4-06	Input value of calibration point 1 of AI2	Range: -10.00V to 10.00V	1.00V	×
C4-07	Sampling value of calibration point 2 of AI2	Range: -10.00V to 10.00V	9.00V	
C4-08	Input value of calibration point 2 of AI2	Range: -10.00V to 10.00V	9.00V	×
C4-09	Sampling value of calibration point 1 of EAI	Range: 0.00V - 10.00V	1.00V	
C4-10	Input value of calibration point 1 of EAI	Range: 0.00V - 10.00V	1.00V	×
C4-11	Sampling value of calibration point 2 of EAI	Range: 0.00V - 10.00V	9.00V	
C4-12	Input value of calibration point 2 of EAI	Range: 0.00V - 10.00V	9.00V	×
Group d Motor and Control Parameters				
Group d0 Parameters of Motor 1				
d0-00	Type of motor 1	0: Ordinary motor 1: Variable frequency motor	0	×
d0-01	Power rating of motor 1	0.4kW - 6553.5kW	Model defined	×
d0-02	Rated voltage of motor 1	0V - 480V	380V	×
d0-03	Rated current of motor 1	0.0A - 6553.5A	Model defined	×
d0-04	Rated frequency of motor 1	0.00Hz - 600.00Hz	50.00Hz	×
d0-05	Number of poles of motor 1	1 - 80	4	×
d0-06	Rated speed of motor 1	0 - 65535r/min	Model defined	×
d0-07	Stator resistance R1 of motor 1	0.001Ω - 65.535Ω	Model defined	×
d0-08	Leakage inductance L1 of motor 1	0.1mH - 6553.5mH	Model defined	×
d0-09	Rotor resistance R2 of motor 1	0.001Ω - 65.535Ω	Model defined	×
d0-10	Mutual inductance L2 of	0.1mH - 6553.5mH	Model	×

	motor 1		defined	
d0-11	No-load current of motor 1	0.0A - 6553.5A	Model defined	×
d0-12	Flux weakening coeff 1 of motor 1	0.0000 - 1.0000	Model defined	×
d0-13	Flux weakening coeff 2 of motor 1	0.0000 - 1.0000	Model defined	×
d0-14	Flux weakening coeff 3 of motor 1	0.0000 - 1.0000	Model defined	×
d0-15	Reserved	Reserved	Reserved	×
d0-16	Reserved	Reserved	Reserved	×
d0-17	Reserved	Reserved	Reserved	×
d0-18	Reserved	Reserved	Reserved	×
d0-19	Reserved	Reserved	Reserved	×
d0-20	Reserved	Reserved	Reserved	×
d0-21	Reserved	Reserved	Reserved	×
d0-22	Parameter identification of motor 1	0: No identification 1: Static identification 2: Rotating identification	0	×
d0-23	Overload protection mode of motor 1	0: No protection 1: Judged from motor current 2: Judged from temperature transducer	1	×
d0-24	Overload protection detection time of motor 1	0.1min - 15.0min	5.0min	×
d0-25	Input channel of temperature transducer signal of motor 1	0: AI1 1: AI2 2: EAI (on IO board)	1	×
d0-26	Thermal protection threshold of temperature transducer for motor 1	0.00V - 10.00V	10.00V	×
Group d1 V/f Control Parameters of Motor 1				
d1-00	V/f curve setting	0: Linear V/f 1: Multi-stage V/f (d1-01 to d1-08) 2: 1.2nd power 3: 1.4th power 4: 1.6th power 5: 1.8th power 6: 2.0nd power 7: V/f separated mode 1 8: V/f separated mode 2	0	×
d1-01	V/f frequency value f3	0.00Hz to rated frequency of motor	50.00Hz	×

d1-02	V/f voltage value V3	0.0% - 100.0%	100.0%	×
d1-03	V/f frequency value f2	d1-05 to d1-01	0.00Hz	×
d1-04	V/f voltage value V2	0.0% to 100.0%	0.0%	×
d1-05	V/f frequency value f1	d1-07 to d1-03	0.00Hz	×
d1-06	V/f voltage value V1	0.0% to 100.0%	0.0%	×
d1-07	V/f frequency value f0	0.00Hz to d1-05	0.00Hz	×
d1-08	V/f voltage value V0	0.0% - 100.0%	0.0%	×
d1-09	Torque boost	0.0% - 30.0%	0.0%	△
d1-10	Slip compensation gain	0.0% - 400.0%	100.0%	△
d1-11	Droop control	0.00Hz to maximum frequency	0.00Hz	△
d1-12	Current limitation mode	0: Disabled 1: Set by d1-13 2: Set by AI1 3: Set by AI2 4: Set by EAI 5: Set by X6/DI	1	×
d1-13	Digital setting of current limit value	20.0% - 200.0%	160.0%	×
d1-14	Current limit coeff on flux weakening	0.001 - 1.000	0.500	△
d1-15	Energy saving percentage	0% - 40.0%	0.0%	△
d1-16	V/f oscillation suppression gain 1	0 - 3000	16	△
d1-17	V/f oscillation suppression gain 2	0 - 3000	20	△
d1-18	Voltage setting on V/f separated pattern	0: d1-19 digital setting 1: Set by AI1 2: Set by AI2 3: Set by EAI 4: Process PID output 5: AI1 + process PID output	0	×
d1-19	Digital set voltage on V/f separated pattern	0.0% - 100.0%	0.0%	△
d1-20	Voltage variation time on V/f separated pattern	0.00s - 600.00s	0.01s	△
Group d2 Vector Control Parameters of Motor 1				
d2-00	Reserved	Reserved	0	×
d2-01	ASR high-speed proportional gain Kp1	0.0 - 20.0	2.0	△
d2-02	ASR high-speed integration time Ti1	0.000s - 8.000s	0.200	△

d2-03	ASR low-speed proportional gain Kp2	0.0 - 20.0	2.0	Δ
d2-04	ASR low-speed integration time Ti2	0.000s - 8.000s	0.200	Δ
d2-05	ASR switching frequency 1	0.00Hz to d2-06	5.00Hz	Δ
d2-06	ASR switching frequency 2	D2-05 to upper limiting frequency	10.00Hz	Δ
d2-07	ASR input filtering time	0.0ms to 500.0ms	0.3ms	Δ
d2-08	ASR output filtering time	0.0ms to 500.0ms	0.3ms	Δ
d2-09	ACR proportion coefficient Kp	0.000 - 4.000	1.000	Δ
d2-10	ACR integration coefficient Ki	0.000 - 4.000	1.000	Δ
d2-11	Pre-excitation time	0.000s - 5.000s	0.200s	Δ
d2-12	Electric-driven torque limitation source	0: d2-14 digital setting 1: Analogue input AI1 2: Analogue input AI2 3: Analogue input EAI (on IO expansion board) 4: X6/DI pulse input 5: Communication	0	×
d2-13	Limitation mode of braking torque	0: d2-15 digital setting 1: Analogue input AI1 2: Analogue input AI2 3: Analogue input EAI (on IO expansion board) 4: X6/DI pulse input 5: Communication	0	×
d2-14	Digital setting of electric-driven torque	0.0% - 200.0%	180.0%	Δ
d2-15	Digital setting of brake torque	0.0% - 200.0%	180.0%	Δ
d2-16	Torque limit coefficient in flux weakening	0.0% - 100.0%	50.0%	Δ
d2-17	Electric-driven slip compensation gain	10.0% - 300.0%	100.0%	Δ
d2-18	Brake slip compensation gain	10.0% - 300.0%	100.0%	Δ
Group d3 Parameters of Motor 2				
d3-00	Type of motor 2	0: Ordinary motor 1: Variable-frequency motor	0	×
d3-01	Power rating of motor 2	0.4kW - 6553.5kW	Model defined	×
d3-02	Rated voltage of motor 2	0V - 480V (for drives 380V level)	380V	×

d3-03	Rated current of motor 2	0.0A - 6553.5A	Model defined	×
d3-04	Rated frequency of motor 2	0.00Hz - 600.00Hz	50.00Hz	×
d3-05	Number of pole pairs of motor 2	1 - 80	4	×
d3-06	Rated speed of motor 2	0 - 65535r/min	Model defined	×
d3-07	Stator resistance R1 of motor 2	0.001Ω - 65.535Ω	Model defined	×
d3-08	Leakage inductance L1 of motor 2	0.1mH - 6553.5mH	Model defined	×
d3-09	Rotor resistance R2 of motor 2	0.001Ω - 65.535Ω	Model defined	×
d3-10	Mutual inductance L2 of motor 2	0.1mH - 6553.5mH	Model defined	×
d3-11	No-load current of motor 2	0.0A - 6553.5A	Model defined	×
d3-12	Flux weakening coeff 1 of motor 2	0.0000 - 1.0000	Model defined	×
d3-13	Flux weakening coeff 2 of motor 2	0.0000 - 1.0000	Model defined	×
d3-14	Flux weakening coeff 3 of motor 2	0.0000 - 1.0000	Model defined	×
d3-15	Reserved	Reserved	Reserved	×
d3-16	Reserved	Reserved	Reserved	×
d3-17	Reserved	Reserved	Reserved	×
d3-18	Reserved	Reserved	Reserved	×
d3-19	Reserved	Reserved	Reserved	×
d3-20	Reserved	Reserved	Reserved	×
d3-21	Reserved	Reserved	Reserved	×
d3-22	Parameter identification of motor 2	0: No action 1: Static identification 2: Rotating identification	0	×
d3-23	Overload protection mode of motor 2	0: No action 1: Judged from motor current 2: Judged from temperature transducer	1	×
d3-24	Overload protection detection time of motor 2	0.1min - 15.0min	5.0min	×
d3-25	Input channel of temperature transducer signal for motor 2	0: Analogue input AI1 1: Analogue input AI2 2: Analogue input EAI (on IO	0	×

		expansion card)		
d3-26	Thermal protection threshold of temperature transducer for motor 2	0.00V - 10.00V	10.00V	×
Group d4 V/f Control Parameter of Motor 2				
d4-00	V/f curve setting	0: Linear V/f 1: Various segments V/f (d4-01 to d4-08) 2: 1.2nd power 3: 1.4th power 4: 1.6th power 5: 1.8th power 6: 2.0nd power 7: V/f separated mode 1 8: V/f separated mode 2	0	×
d4-01	V/f frequency value f3	0.00Hz - rated frequency of motor	50.00Hz	×
d4-02	V/f voltage value V3	0.0% - 100.0%	100.0%	×
d4-03	V/f frequency value f2	d4-05 to d4-01	0.00Hz	×
d4-04	V/f voltage value V2	0.0% - 100.0%	0.0%	×
d4-05	V/f frequency value f1	d4-07 to d4-03	0.00Hz	×
d4-06	V/f voltage value V1	0.0% - 100.0%	0.0%	×
d4-07	V/f frequency value f0	0.00Hz to d4-05	0.00Hz	×
d4-08	V/f voltage value V0	0.0% - 100.0%	0.0%	×
d4-09	Torque boost	0.0% - 30.0%	0.0%	△
d4-10	Slip compensation gain	0.0% - 300.0%	100.0%	△
d4-11	Drooping FREQ of droop control	0.00Hz - mximum frequency	0.00Hz	△
d4-12	Current limitation mode	0: Disabled 1: Set by d4-13 2: Set by AI1 3: Set by AI2 4: Set by EAI 5: Set by X6/DI	1	×
d4-13	Digital setting of current limit value	20.0% - 200.0%	160.0%	×
d4-14	Current limit coeff on flux weakening	0.001 - 1.000	0.500	△
d4-15	Energy saving percentage	0.0% - 40.0%	0.0%	△
d4-16	V/f oscillation suppression gain 1	0 - 3000	16	
d4-17	V/f oscillation suppression gain 2	0 - 3000	20	
d4-18	Voltage setting on V/f	0: Digital setting by d1-19	0	

	separated pattern	1: Set through analogue input AI1 2: Set through analogue input AI2 3: Set through analogue input EAI 4: Process PID output 5: AI1 + process PID output		
d4-19	Digital voltage setting for V/f separation pattern	0.0% - 100.0%	0.0%	
d4-20	Voltage variation time on V/f separated pattern	0.00s - 600.00s	0.01s	
Group d5 Vector Control Parameter of Motor 2				
d5-00	Reserved	Reserved	Reserve	x
d5-01	ASR Hi-speed proportional gain Kp1	0.0 - 20.0	2.0	
d5-02	ASR Hi-speed integration time Ti1	0.000s - 8.000s	0.200	
d5-03	ASR low-speed proportional gain Kp2	0.0 - 20.0	2.0	
d5-04	ASR low-speed integration time Ti2	0.000s - 8.000s	0.200	
d5-05	ASR switching frequency 1	0.00Hz to d5-06	5.00Hz	
d5-06	ASR switching frequency 2	D5-05 to upper limiting frequency	10.00Hz	
d5-07	ASR input filtering time	0.0ms to 500.0ms	0.3ms	
d5-08	ASR output filtering time	0.0ms to 500.0ms	0.3ms	
d5-09	ACR scale factor Kp	0.000 - 4.000	1.000	
d5-10	ACR integration coeff Ki	0.000 - 4.000	1.000	
d5-11	Pre-excitation time	0.000s - 5.000s	0.200s	
d5-12	Limitation mode of electric torque	0: d5-14 digital setting 1: AI1 2: AI2 3: EAI (on IO expansion board) 4: X6/DI pulse input 5: Communication	0	x
d5-13	Limitation mode of braking torque	0: d5-15 digital setting 1: AI1 2: AI2 3: EAI (on IO expansion board) 4: X6/DI pulse input 5: Communication	0	x
d5-14	Digital setting of electric torque limit value	0.0% - 200.0%	180.0%	
d5-15	Digital setting of braking torque limit value	0.0% - 200.0%	180.0%	
d5-16	Flux weakening torque limit	0.0% - 100.0%	50.0%	

	coeff			
d5-17	Electric slip compensation gain	10.0% - 300.0%	100.0%	
d5-18	Brake slip compensation gain	10.0% - 300.0%	100.0%	
Group E Enhancement Function and Protection Parameters				
Group E0 Enhancement Function				
E0-00	Carrier frequency	≤15kW: 0.7kHz - 16.0kHz, factory default: 8.0 kHz	Model defined	
E0-01	PWM optimization	Unit's place: carrier frequency adjusted with temperature 0: Automatic adjustment 1: No adjustment Decade: PWM modulation mode 0: Five-segment and seven-segment automatic switchover 1: Five-segment mode 2: Seven-segment mode Hundreds place: over-modulation adjustment 0: Disabled 1: Enabled Thousands place: adjusted with freq	0100	×
E0-02	Command when running time attained	Unit's place: command when consecutive running time attained: 0: Continue to run 1: Stop and fault alarm Decade: command when accumulative running time attained: 0: Continue to run 1: Stop and fault alarm Hundreds place: unit of running time 0: Second 1: Hour	000	×
E0-03	Consecutive running time	0.0s(h) - 6000.0s(h)	00s(h)	×
E0-04	Accumulative running time setting	0.0s(h) - 6000.0s(h)	00s(h)	×
E0-05	Contracting brake control	0: Disabled 1: Enabled	0	×
E0-06	Contracting brake release frequency	0.00Hz - 10.00Hz	2.50Hz	×
E0-07	Contracting brake release	0.0% - 200.0%	120.0%	×

	current			
E0-08	Accel delay time after contracting brake release	0.0s - 10.0s	1.0s	×
E0-09	Contracting brake frequency	0.00Hz - 10.00Hz	2.00Hz	×
E0-10	Contracting brake suction waiting time	0.0s - 10.0s	0.0s	×
E0-11	Contracting brake suction holding time	0.0s - 10.0s	1.0s	×
Group E1 Protection Parameters				
E1-00	Overvoltage stall	0: Prohibited 1: Allowed	1	×
E1-01	Overvoltage stall protection voltage	120% - 150%	135%	×
E1-02	Undervoltage stall	0: Disabled 1: Enabled	0	×
E1-03	Overload alarm	Unit's place: detection option: 0: Always detect 1: Detect at constant speed only Decade: compared object: 0: Rated current of motor 1: Rated current of drive Hundreds place: alarm option 0: Alarm and continue to run 1: Protection enabled and coast to stop	000	×
E1-04	Overload alarm threshold	20.0% - 200.0%	130.0%	
E1-05	Overload alarm activated time that exceeding threshold	0.1s - 60.0s	5.0s	
E1-06	Protection action 1	Unit's place: reserved Decade: temperature sampling disconnection action: 0: Protection enabled and coast stop 1: Alarm and continue to run Hundreds place: abnormal EEPROM : 0: Protection enabled and coast stop 1: Alarm and continue to run Thousands place: abnormal terminal communication: 0: Protection enabled and coast stop 1: Alarm and continue to run	0000	×

E1-07	Protection action 2	<p>Unit's place: abnormal keypad communication: 0: Protection enabled and coast stop 1: Alarm and continue to run Decade: current detection circuit failed 0: Protection enabled and coast stop 1: Alarm and continue to run Hundreds place: abnormal contactor: 0: Protection enabled and coast stop 1: Alarm and continue to run Thousands place: input/output phase loss: 0: No protection, for input phase loss and output phase loss 1: No protection for input phase loss, protection enabled for output phase loss 2: Protection enabled for input phase loss, no protection for output phase loss 3: Protection enabled both for input phase loss and output phase loss</p>	0000	×
E1-08	Fault memory after power loss	<p>0: Not memorized after power loss 1: Memorized after power loss</p>	0	×
E1-09	Times of automatic reset	0 - 20	0	×
E1-10	Interval of automatic reset	2.0s - 20.0s	2.0s	×
E1-11	Relay action on drive fault	<p>Unit's place: when undervoltage fault occurs 0: No action 1: Action enabled Decade: when fault locked 0: No action 1: Action enabled Hundreds place: interval of automatic reset 0: No action 1: Action enabled</p>	010	×
E1-12	Cooling fan control	<p>0: Auto run 1: Always run</p>	0	
E1-13	Drive thermal alarm threshold	0.0 to 100.0	70.0	

Group F Application				
Group F0 Process PID				
F0-00	PID setting	0: F0-01 digital setting 1: AI1 2: AI2 3: EAI (on IO expansion board) 4: X6/DI pulse input 5: Communication	0	×
F0-01	PID digital setting	0.0% - 100.0%	50.0%	
F0-02	PID feedback	0: AI1 1: AI2 2: EAI (on IO expansion board) 3: AI1+AI2 4: AI1-AI2 5: Max {AI1, AI2} 6: Min {AI1, AI2} 7: X6/DI pulse input 8: Communication	0	×
F0-03	PID adjustment	Unit's place: output frequency 0: Must be the same direction as setting running direction 1: Opposite direction allowed Decade: integration selection 0: Integral continued when frequency attains upper/lower frequency 1: Integral stopped when frequency attains upper/lower limit	11	×
F0-04	PID positive and negative adjustment	0: Positive adjustment 1: Negative adjustment	0	×
F0-05	Filtering time of PID setting	0.00s - 60.00s	0.00s	
F0-06	Filtering time of PID feedback	0.00s - 60.00s	0.00s	
F0-07	Filtering time of PID output	0.00s - 60.00s	0.00s	
F0-08	Proportional gain Kp1	0.0 - 100.0	2.0	
F0-09	Integration time Ti1	0.0s - 100.0s	1.0s	
F0-10	Differential time Td1	0.0s - 100.0s	0.0s	
F0-11	Proportional gain Kp2	0.0 - 100.0	2.0	
F0-12	Integration time Ti2	0.0s - 100.0s	1.0s	
F0-13	Differential time Td2	0.0s - 100.0s	0.0s	

F0-14	PID parameter switch	0: No switch, determined by parameters Kp1, Ti1 and Td1 1: Auto switch on the basis of input offset 2: Switched by terminal	0	×
F0-15	Input offset under PID auto switch	0.0% - 100.0%	20.0%	
F0-16	Sampling period T	0.001s - 50.000s	0.002s	
F0-17	PID offset limit	0.0% - 100.0%	0.0%	
F0-18	PID differential limit	0.0% - 100.0%	0.5%	
F0-19	PID initial value	0.0% - 100.0%	0.0%	×
F0-20	Holding time of PID initial value	0.0s - 3600.0s	0.0s	
F0-21	PID feedback loss detection value	0.0% - 100.0%	0.0%	
F0-22	PID feedback loss detection time	0.0s - 30.0s	1.0s	
F0-23	Maximum frequency if it is opposite to command running direction	0.00Hz - maximum frequency	50.00Hz	
F0-24	PID computation option	0: No computation in stop status 1: Computation continued in stop status	0	
Group F1 Multi-step Frequency				
F1-00	Frequency command source of multi-step 0	0: Digital setting F1-02 1: Digital setting b0-02 + keypad / adjustment 2: Digital setting b0-02 + terminal UP/DOWN adjustment 3: AI1 4: AI2 5: EAI (on IO expansion board) 6: X6/DI pulse input 7: Process PID output 8: Communication	0	×
F1-01	Frequency command source of multi-step 1	0: Digital setting F1-03 1: Digital setting b0-04 + keypad / adjustment 2: Digital setting b0-04 + terminal UP/DOWN 3: AI1 4: AI2 5: EAI (on IO expansion board)	0	×

		6: X6/DI pulse input 7: Process PID output 8: Communication		
F1-02	Multi-step frequency 0	Lower limit frequency - upper limit frequency	0.00Hz	
F1-03	Multi-step frequency 1	Lower limit frequency - upper limit frequency	0.00 Hz	
F1-04	Multi-step frequency 2	Lower limit frequency - upper limit frequency	0.00 Hz	
F1-05	Multi-step frequency 3	Lower limit frequency - upper limit frequency	0.00 Hz	
F1-06	Multi-step frequency 4	Lower limit frequency - upper limit frequency	0.00 Hz	
F1-07	Multi-step frequency 5	Lower limit frequency - upper limit frequency	0.00 Hz	
F1-08	Multi-step frequency 6	Lower limit frequency - upper limit frequency	0.00 Hz	
F1-09	Multi-step frequency 7	Lower limit frequency - upper limit frequency	0.00 Hz	
F1-10	Multi-step frequency 8	Lower limit frequency - upper limit frequency	0.00 Hz	
F1-11	Multi-step frequency 9	Lower limit frequency - upper limit frequency	0.00 Hz	
F1-12	Multi-step frequency 10	Lower limit frequency - upper limit frequency	0.00 Hz	
F1-13	Multi-step frequency 11	Lower limit frequency - upper limit frequency	0.00 Hz	
F1-14	Multi-step frequency 12	Lower limit frequency - upper limit frequency	0.00 Hz	
F1-15	Multi-step frequency 13	Lower limit frequency - upper limit frequency	0.00 Hz	
F1-16	Multi-step frequency 14	Lower limit frequency - upper limit frequency	0.00 Hz	
F1-17	Multi-step frequency 15	Lower limit frequency - upper limit frequency	0.00 Hz	
Group F2 Simple PLC (based on multi-step frequency)				
F2-00	Running mode of simple PLC	Unit's place: PLC running mode 0: Stop after a single cycle 1: Continue to run with the last frequency after a single cycle 2: Repeat cycles Decade: power loss memory 0: Memory disabled on power loss	0000	×

		<p>1: Memory enabled on power loss Hundreds place: started mode 0: Run from the first step "multi-step frequency 0" 1: Continue to run from the step of stop (or fault) 2: Continue to run from the step and frequency at which the running stopped (or fault occurred) Thousands place: unit of simple PLC running time 0: Second (s) 1: Minute (min)</p>		
F2-01	Setting of multi-step 0	<p>Unit's place: frequency command 0: Multi-step frequency 0 (F1-02) 1: AI1 2: AI2 3: EAI (on IO expansion board) 4: X6/DI pulse input 5: Process PID output 6: Multi-step frequency 7: Communication Decade: running direction 0: Forward 1: Reverse 2: Determined by run command Hundreds place: Accel/Decel time option 0: Accel/Decel time 1 1: Accel/Decel time 2 2: Accel/Decel time 3 3: Accel/Decel time 4</p>	000	x
F2-02	Running time of step 0	0.0s(min) - 6000.0s(min)	0.0s	
F2-03	Setting of step 1	<p>Unit's place: frequency setting 0: Multi-step frequency 1 (F1-03) 1 - 7: Same as F2-01 Decade: running direction (same as F2-01) Hundreds place: Accel/Decel time option (same as F2-01)</p>	000	x
F2-04	Running time of step 1	0.0s(min) - 6000.0s(min)	0.0s	
F2-05	Setting of step 2	<p>Unit's place: frequency setting 0: Multi-step frequency 2 (F1-04) 1 - 7: Same as F2-01</p>	000	x

		Decade: running direction (same as F2-01) Hundreds place: Accel/Decel time option (same as F2-01)		
F2-06	Running time of step 2	0.0s(min) - 6000.0s(min)	0.0s	
F2-07	Setting of step 3	Unit's place: frequency setting 0: Multi-step frequency 3 (F1-05) 1 - 7: Same as F2-01 Decade: running direction (same as F2-01) Hundreds place: Accel/Decel time option (same as F2-01)	000	×
F2-08	Running time of step 3	0.0s(min) - 6000.0s(min)	0.0s	
F2-09	Setting of step 4	Unit's place: frequency setting 0: Multi-step frequency 4 (F1-06) 1 - 7: Same as F2-01 Decade: running direction (same as F2-01) Hundreds place: Accel/Decel time option (same as F2-01)	000	×
F2-10	Running time of step 4	0.0s(min) - 6000.0s(min)	0.0s	
F2-11	Setting of step 5	Unit's place: frequency setting 0: Multi-step frequency 5 (F1-07) 1 - 7: Same as F2-01 Decade: running direction (same as F2-01) Hundreds place: Accel/Decel time option (same as F2-01)	000	×
F2-12	Running time of step 5	0.0s(min) - 6000.0s(min)	0.0s	
F2-13	Setting of step 6	Unit's place: frequency setting 0: Multi-step frequency 6 (F1-08) 1 - 7: Same as F2-01 Decade: running direction (same as F2-01) Hundreds place: Accel/Decel time option (same as F2-01)	000	×
F2-14	Running time of step 6	0.0s(min) - 6000.0s(min)	0.0s	
F2-15	Setting of step 7	Unit's place: frequency setting 0: Multi-step frequency 7 (F1-09) 1 - 7: Same as F2-01 Decade: running direction (same as F2-01) Hundreds place: Accel/Decel time option (same as F2-01)	000	×

F2-16	Running time of step 7	0.0s(min) - 6000.0s(min)	0.0s	
F2-17	Setting of step 8	Unit's place: frequency setting 0: Multi-step frequency 8 (F1-10) 1 - 7: Same as F2-01 Decade: running direction (same as F2-01) Hundreds place: Accel/Decel time option (same as F2-01)	000	×
F2-18	Running time of step 8	0.0s(min) - 6000.0s(min)	0.0s	
F2-19	Setting of step 9	Unit's place: frequency setting 0: Multi-step frequency 9 (F1-11) 1 - 7: Same as F2-01 Decade: running direction (same as F2-01) Hundreds place: ACC/DEC time option (same as F2-01)	000	×
F2-20	Running time of step 9	0.0s(min) - 6000.0s(min)	0.0s	
F2-21	Setting of step 10	Unit's place: frequency setting 0: multi-step frequency 10 (F1-12) 1 - 7: same as F2-01 Decade: running direction (same as F2-01) Hundreds place: Accel/Decel time option (same as F2-01)	000	×
F2-22	Running time of step 10	0.0s(min) - 6000.0s(min)	0.0s	
F2-23	Setting of step 11	Unit's place: frequency setting 0: Multi-step frequency 11 (F1-13) 1 - 7: Same as F2-01 Decade: running direction (same as F2-01) Hundreds place: Accel/Decel time option (same as F2-01)	000	×
F2-24	Running time of step 11	0.0s(min) - 6000.0s(min)	0.0s	
F2-25	Setting of step 12	Unit's place: frequency setting 0: Multi-step frequency 12 (F1-14) 1 - 7: Same as F2-01 Decade: running direction (same as F2-01) Hundreds place: Accel/Decel time option (same as F2-01)	000	×
F2-26	Running time of step 12	0.0s(min) - 6000.0s(min)	0.0s	
F2-27	Setting of step 13	Unit's place: frequency setting 0: Multi-step frequency 13 (F1-15) 1 - 7: Same as F2-01	000	×

		Decade: running direction (same as F2-01) Hundreds place: Accel/Decel time option (same as F2-01)		
F2-28	Running time of step 13	0.0s(min) - 6000.0s(min)	0.0s	
F2-29	Setting of segment 14	Unit's place: frequency setting 0: Multi-step frequency 14 (F1-16) 1 - 7: Same as F2-01 Decade: running direction (same as F2-01) Hundreds place: Accel/Decel time option (same as F2-01)	000	×
F2-30	Running time of step 14	0.0s(min) - 6000.0s(min)	0.0s	
F2-31	Setting of step 15	Unit's place: frequency setting 0: Multi-step frequency 15 (F1-17) 1 - 7: Same as F2-01 Decade: running direction (same as F2-01) Hundreds place: Accel/Decel time option (same as F2-01)	000	×
F2-32	Running time of step 15	0.0s(min) - 6000.0s(min)	0.0s	
Group F3 Wobble Frequency and Fixed Length Count				
F3-00	Wobble frequency function setting	0: Wobble frequency function disabled 1: Wobble frequency function enabled	0	×
F3-01	Wobble frequency running setting	Unit's place: started method 0: Automatically 1: Started by terminal Decade: amplitude control 0: Relative to center frequency 1: Relative to maximum frequency Hundreds place: wobble frequency memorized when stop 0: Memory enabled 1: Memory disabled Thousands place: wobble frequency memorized on power loss 0: Memory enabled 1: Memory disabled	0000	×
F3-02	Pre-wobble frequency	0.00Hz - 600.00Hz	0.00Hz	
F3-03	Pre-wobble frequency holding time	0.0s - 3600.0s	0.0s	
F3-04	Wobble frequency	0.0% - 50.0%	0.0%	

	amplitude			
F3-05	Hop frequency	0.0% - 50.0% (relative to F3-04)	0.0%	
F3-06	Cycle of wobble frequency	0.1s - 999.9s	0.0s	
F3-07	Triangular wave ramp-up time	0.0% - 100.0% (of wobble frequency cycle)	0.0%	
F3-08	Length unit	0: m 1: 10m	0	
F3-09	Length setting	0 - 65535	1000	
F3-10	Number of pulses per meter	0.1 - 6553.5	100.0	
F3-11	Command when the length attained	0: Not stop 1: Stop	0	
F3-12	Set count value	1 - 65535	1000	
F3-13	Designated count value	1 - 65535	1000	
Group H Communication Parameters				
Group H0 MODBUS Communication Parameters				
H0-00	RS-485 port terminal resistance	0: 100Ω terminal resistance not connected 1: 100Ω terminal resistance connected	0	×
H0-01	RS-485 port communication configuration	Unit's place: baud rate 0: 4800bps 1: 9600bps 2: 19200bps 3: 38400bps 4: 57600bps 5: 115200bps Decade: data format 0: 1-8-2-N format, RTU 1: 1-8-1-E format, RTU 2: 1-8-1-O Format, RTU 3: 1-7-2-N format, ASCII 4: 1-7-1-E format, ASCII 5: 1-7-1-O format, ASCII Hundreds place: connection type 0: Direct cable connection (232/485) 1: MODEM (232)	001	×
H0-02	RS-485 communication address	0 - 247, 0 is broadcast address	5	×
H0-03	Time out detection	0.0s - 1000.0s	0.0s	×
H0-04	Communication time delay	0ms - 1000ms	0ms	×

H0-05	Master/Slave option	0: PC controls this drive 1: As master 2: As slave	0	x
H0-06	Parameter store address	0:b0-02 1:F0-01	0	x
H0-07	Proportional factor of received frequency	0.0% - 100.0%	100.0%	
Group L Keys and Display of Keypad				
Group L0 Keys of Keypad				
L0-00	MF key setting	0: No function 1: Forward jog 2: Reverse jog 3: Forward/reverse switchover 4: Emergency stop 1 (set Decel time on b2-09) 5: Emergency stop 2 (coast to stop) 6: Run command sources shifted	0	
L0-01	Keys locked option	0: Not locked 1: Full locked 2: Keys locked other than RUN, STOP/RESET 3: Keys locked other than STOP/RESET 4: Keys locked other than >>	0	
L0-02	Function of STOP key	0: STOP key valid only when under keypad control 1: STOP key valid under any run command source	0	
L0-03	Frequency adjustment through keys /	Unit's place: option on stop 0: Clear on stop 1: Holding on stop Decade: option on power loss 0: Clear on power loss 1: Holding on power loss Hundreds place: integrating option 0: Integrating disabled 1: Integrating enabled	000	
L0-04	Step size of frequency adjustment through keys /	0.00Hz/s - 10.00Hz/s	0.03 Hz/s	
Group L1 LED Display Setting				
L1-00	LED displayed parameters setting 1 on running status	Setting of binary system: 0: Display disabled 1: Display enabled	000F	

		<p>Unit's place: BIT0: Running frequency (Hz) BIT1: Command frequency (Hz) BIT2: Bus voltage (V) BIT3: Output current (A) Decade: BIT0: Output torque (%) BIT1: Output power (kW) BIT2: Output voltage (V) BIT3: Motor speed (r/min) Hundreds place: BIT0: AI1 (V) BIT1: AI2 (V) BIT2: EAI (V) BIT3: Reserved Thousands place: BIT0: DI BIT1: External count value BIT2: Reserved BIT3: Reserved Note: when this parameter is set to 0000, running frequency (Hz) would be displayed as default</p>		
L1-01	LED displayed parameters setting 2 on running status	<p>Setting of binary system: 0: Display disabled 1: Display enabled Unit's place: BIT0: Running linear speed (m/s) BIT1: Set linear speed (m/s) BIT2: Input terminal status BIT3: Output terminal status Decade: BIT0: PID setting (%) BIT1: PID feedback (%) BIT2: Set length (m) BIT3: Actual length (m) Hundreds place: reserved Thousands place: reserved</p>	0000	
L1-02	LED displayed parameters setting on stop status	<p>Setting of binary system: 0: Display disabled 1: Display enabled Unit's place: BIT0: Command frequency (Hz) BIT1: Bus voltage (V)</p>	0003	

		BIT2: Input terminal status BIT3: Output terminal status Decade: BIT0: AI1 (V) BIT1: AI2 (V) BIT2: EAI (V) BIT3: Reserved Hundreds place: BIT0: PID setting (%) BIT1: PID feedback (%) BIT2: Set length (m) BIT3: Actual length (m) Thousands place: BIT0: Running linear speed (m/s) BIT1: Set linear speed (m/s) BIT2: External count value BIT3: DI Note: when this function code is set to 0000, the set frequency would be displayed as default (Hz)		
L1-03	Linear speed COEFF	0.1% - 999.9%	100.0%	
Group U Monitoring				
Group U0 Status Monitoring				
U0-00	Running frequency	0.00Hz - 600.00Hz	0.00Hz	
U0-01	Set frequency	0.00Hz - 600.00Hz	0.00Hz	
U0-02	Bus voltage	0V - 65535V	0V	
U0-03	Output voltage	0V - 65535V	0V	
U0-04	Output current	0.0A - 6553.5A	0.0A	
U0-05	Output torque	0.0% - 300.0%	0.0%	
U0-06	Output power	0.0% - 300.0%	0.0%	
U0-07	Master frequency command source	0: Digital setting + adjustment through / on keypad 1: Digital setting + terminal UP/DOWN adjustment 2: Analogue input AI1 3: Analogue input AI2 4: Analogue input EAI 5: X6/DI pulse input 6: Process PID output 7: PLC 8: Multi-step frequency 9: Communication	0	
U0-08	Auxiliary frequency command source	0: No command 1: Digital setting + adjustment	0	

		through / on keypad 2: Digital setting + terminal UP/DOWN adjustment 3: Analogue input AI1 4: Analogue input AI2 5: Analogue input EAI 6: X6/DI pulse input 7: Process PID output 8: PLC 9: Multi-step frequency 10: Communication		
U0-09	Master frequency setting	0.00Hz - 600.00Hz	0.00Hz	
U0-10	Auxiliary frequency setting	0.00Hz - 600.00Hz	0.00Hz	
U0-11	Drive status	Unit's place: running status 0: Accelerating 1: Decelerating 2: Constant speed running Decade: drive status 0: Stop 1: Running status 2: Motor parameters are being identified	00	
U0-12	AI1 input voltage	0.00V - 10.00V	0.00V	
U0-13	AI2 input voltage	-10.00V to 10.00V	0.00V	
U0-14	EAI input voltage	0.00V - 10.00V	0.00V	
U0-15	AO1 output	0.0% - 100.0%	0.0%	
U0-16	EAO output	0.0% - 100.0%	0.0%	
U0-17	X6/DI HF pulse frequency	0.0kHz - 50.0kHz	0.0kHz	
U0-18	Status of digital input terminal	0 - 7F	00	
U0-19	Status of digital output terminal	0 - 7	0	
U0-20	PID set	0.0% - 100.0%	0.0%	
U0-21	PID feedback	0.0% - 100.0%	0.0%	
U0-22	PID input offset	-100.0% to 100.0%	0.0%	
U0-23	PLC step	0 - 15	0	
U0-24	V/f separated target voltage	0.0% - 100.0%	0.0%	
U0-25	V/f separated actual output voltage	0.0% - 100.0%	0.0%	
U0-26	Reserved	Reserved	Reserved	
U0-27	Reserved	Reserved	Reserved	
U0-28	Reserved	Reserved	Reserved	
U0-29	Reserved	Reserved	Reserved	

U0-30	Cumulative power-up time	0h - 65535h	0h	
U0-31	Cumulative running time	0h - 65535h	0h	
U0-32	Lowest temperature of heat sink	-40.0 to 100.0	0.0	
U0-33	Highest temperature of heat sink	-40.0 to 100.0	0.0	
U0-34	FAL fault source	0: No fault source 1: FAL itself 2: 5V fault 3: Ground fault 4: OC fault 5: OU fault 6: Other sources	0	
U0-35	Terminal count value	0 - 65535	0	
U0-36	Run command record at LoU	0 - 1	0	
U0-37	Fault code record at LoU	0 - 100	0	
U0-38	Reserved	Reserved	Reserved	
U0-39	Current detection fault source	0: No fault source 1: IU 2: IV 3: IW	0	
U0-40	Higher-place numbers of actual length	0 - 65	0	
U0-41	Lower-place numbers of actual length	0 - 65535	0	
U0-42	Higher-place numbers of keypad / stored value	-1 to 1	0	
U0-43	Lower-place numbers of keypad / stored value	0.00 - 655.35 Hz	0.00Hz	
U0-44	Higher-place numbers of terminal UP/DOWN stored value	-1 to 1	0	
U0-45	Lower-place numbers of terminal UP/DOWN stored value	0.00 - 655.35 Hz	0.00Hz	
U0-46	Reserved	Reserved	Reserved	
U0-47	Reserved	Reserved	Reserved	
U0-48	Reserved	Reserved	Reserved	
U0-49	Reserved	Reserved	Reserved	
U0-50	Reserved	Reserved	Reserved	

U0-51	Reserved	Reserved	Reserved	
U0-52	Center FREQ of wobble FREQ	0 - 600.00 Hz	0.00 Hz	
Group U1 Fault Record				
U1-00	Code of the latest fault	0: No fault 1: Accel overcurrent 2: Constant-speed overcurrent 3: Decel overcurrent 4: Accel overvoltage 5: Constant-speed overvoltage 6: Decel overvoltage 7: Module protection 8: Parameter identification failed 9: Drive overloaded 10: Motor overloaded 11: Current detection abnormal 12: Ground short-circuit protection at output side 13: Input power supply abnormal 14: Phase loss at output side 15: Inverter module overloaded protection 16: Radiator thermal protection 17: Motor (PTC) thermal protection 18: Module temperature detection disconnection 19: Reserved 20: Expansion board connection abnormal 21: Reserved 22: Drive lines connection abnormal 23: Analogue terminal functional mutex 24: External equipment malfunction 25: Reserved 26: Continuous running time reached 27: Accumulative running time reached 28: Power supply abnormal during running 29: EEPROM read/write fault 30: Contactor close fault 31: Port communication abnormal 32: Keypad communication abnormal	0	

		33: Parameter copy fault 34: Reserved 35: Software version compatibility fault 36: CPU interference as a fault 37: Reference protection 38: 5V power supply out-of-limit 39: 10V power supply out-of-limit 40: AI input out-of-limit 41: Undervoltage protection 42: Reserved 43: Reserved 44: Reserved 45: PID feedback loss		
U1-01	Running frequency when the latest fault occurred	0.00Hz - 600.00Hz	0.00Hz	
U1-02	Output current when the latest fault occurred	0.0A - 6553.5A	0.0A	
U1-03	Bus voltage when the latest fault occurred	0V - 10000V	0V	
U1-04	Rectifier bridge temperature when the latest fault occurred	-40.0 to 100.0	0.0	
U1-05	Inverter bridge temperature when the latest fault occurred	-40.0 to 100.0	0.0	
U1-06	Status of input terminal when the latest fault occurred	0 - FFFF	0000	
U1-07	Status of output terminal when the latest fault occurred	0 - FFFF	0000	
U1-08	Cumulative running time when the latest fault occurred	0h - 65535h	0h	
U1-09	Code of previous fault	Same as U1-00	0	
U1-10	Running frequency when previous fault occurred	0.00Hz - 600.00Hz	0.00Hz	
U1-11	Output current when previous fault occurred	0.0A - 6553.5A	0.0A	
U1-12	Bus voltage when previous fault occurred	0V - 10000V	0V	
U1-13	Rectifier bridge temperature when	-40.0 to 100.0	0.0	

	previous fault occurred			
U1-14	Inverter bridge temperature when previous fault occurred	-40.0 to 100.0	0.0	
U1-15	Status of input terminal when previous fault occurred	0 - FFFF	0000	
U1-16	Status of output terminal when previous fault occurred	0 - FFFF	0000	
U1-17	Cumulative running time when previous fault occurred	0h - 65535h	0h	
U1-18	Before-previous fault code	Same as U1-00	0	
U1-19	Running frequency when before-previous fault occurred	0.00Hz - 600.00Hz	0.00Hz	
U1-20	Output current when before-previous fault occurred	0.0A - 6553.5A	0.0A	
U1-21	Bus voltage when before-previous fault occurred	0V - 1000V	0V	
U1-22	Rectifier bridge temperature when before-previous fault occurred	-40.0 to 100.0	0.0	
U1-23	Inverter bridge temperature when before-previous fault occurred	-40.0 to 100.0	0.0	
U1-24	Status of input terminal when before-previous fault occurred	0 - FFFF	0000	
U1-25	Status of output terminal when before-previous fault occurred	0 - FFFF	0000	
U1-26	Cumulative running time when before-previous fault occurred	0h - 65535h	0h	

Chapter 6 Specification of Parameters

Group A System Parameter and Parameter Management

Group A0 System Parameters

A0-00	Setting of user password	Range: 0 - FFFF	Factory default: 0000
-------	--------------------------	-----------------	--------------------------

Setting of password:

A non-zero four-digital number could be set as a user password by entering this password into A0-00 and pressing ENT key to confirm once, then reenter and reconfirm it once again within 10 seconds. Once this password has been successfully set, the word "P-SEt" would be displayed. The password setting will take effect as long as there is no operation on keypad within 5 minutes, or cutting the power off and power up again .

Change password:

Access A0-00 after entering the original four-digit password (at this point, A0-00 displays 0000) and set the new password following the above-noted procedure.

Password clearance:

Access A0-00 after entering the original four-digit password (at this point, A0-00 displays 0000), enter 0000 twice and press ENT key to make confirmation. In this way, password is successfully cleared and the word "P-CLr" is displayed.

A0-01	Display of parameters	Range: 0 - 3	Factory default: 0
-------	-----------------------	--------------	-----------------------

This parameter sets the display/hide of parameters.

0: Display all parameters (A1-20 - A1-21 parameter display/hide is valid)

1: Only display parameters A0-00 and A0-01

2: Only display A0-00, A0-01 and user-defined parameters A1-00 - A1-19

3: Only display A0-00, A0-01, and the parameters different with factory default

A0-02	Parameter protection	Range: 0 - 1	Factory default: 0
-------	----------------------	--------------	-----------------------

0: All parameter programming allowed

1: Only A0-00 and this parameter programming allowed

When this parameter is set to 1, all parameters other than A0-00 and A0-02 are not allowed to modify. Set A0-02 to 0 before the modification of other parameters.

A0-03	Parameter initialization	Range: 0 - 4	Factory default: 0
-------	--------------------------	--------------	-----------------------

0: No operation

1: Clear fault record

When this parameter is set to 1, all fault record of Group U1 will be cleared.

2: Restore all parameters to factory default (excluding motor parameters)

3: Restore all parameters to factory default (including motor parameters)

4: Restore all parameters to backup parameters

A0-04	Parameter backup	Range: 0 - 1	Factory default: 0
-------	------------------	--------------	-----------------------

0: No operation

1: Backup all parameters

A0-05	Copy of parameter	Range: 0 - 3	Factory default: 0
-------	-------------------	--------------	-----------------------

0: No operation

1: Upload all parameters other than Group U to keypad

2: Download all parameters of keypad other than d0-01 - d0-18 and d3-01 - d3-18 to drive

3: Download all parameters of keypad to drive

A0-06	Type of drive	Range: 0 - 1	Factory default: 0
-------	---------------	--------------	-----------------------

0: Type G (applicable to constant-torque load)

1: Type L (applicable to light-duty load)

A0-07	power supply type of the drive	Range: 0 - 1	Factory default: 0
-------	--------------------------------	--------------	-----------------------

0: AC input

Apply AC power supply to the drive through R, S and T.

1: DC input

Set this parameter to 1 when applying DC power supply via ⊕1 and ⊖ to the drive

A0-08	selection of motor 1/motor 2	Range: 0 - 1	Factory default: 0
-------	---------------------------------	--------------	-----------------------

0: Motor 1

Select the current loaded motor as motor 1. Set the parameters of motor 1 in parameter groups d0 - d2.

1: Motor 2

Select the current loaded motor as motor 2. Set the parameters of motor 1 in parameter

groups d3 - d5.

The current loaded motor can also be selected through digital input terminal "motor 1/2 switchover" as shown in Table 6-1:

Table 6-1

A0-08	Motor 1/2 switchover terminal	Motor selection
0	OFF	Motor 1
0	ON	Motor 2
1	OFF	Motor 2
1	ON	Motor 1

A0-09	Motor control technique	Range: 00 - 22	Factory default: 00
-------	-------------------------	----------------	------------------------

□ Unit's place: control technique of motor 1

0: V/f control

Constant Volt/Hertz ratio control: Applicable to such cases in which the performance requirement to the drive is not rigorous, or using one drive to drive several motors, or it is difficult to identify motor parameters correctly, etc. When motor 1 under V/f control is selected, need to set related parameters group d1 well.

1: Sensor-less vector control 1

This helps achieve high-performance control without encoder and provides strong adaptability of load. Under this selection, please correctly set motor parameters of Group d0 and vector control parameters of Group d2.

2: Sensor-less vector control 2

This helps achieve high-performance control without encoder. This control technique is superior to sensor-less vector control 1. Under this selection, please correctly set motor parameters of Group d0 and vector control parameters of Group d2.

□ Decade: control technique of motor 2

0: V/f control

Constant Volt/Hertz ratio control: Applicable to such cases in which the performance requirement to the drive is not rigorous, or using one drive to drive several motors, or it is difficult to identify motor parameters correctly, etc. When motor 1 under V/f control is selected, need to set related parameters group d4 well.

1: sensor-less vector control 1

This helps achieve high-performance control without encoder and provides strong adaptability of load. Under this selection, please correctly set motor parameters of Group d3 and vector control parameters of Group d5.

2: Sensor-less vector control 2

This helps achieve high-performance control without encoder. This control technique is superior to sensor-less vector control 1. Under this selection, please correctly set motor parameters of Group d3 and vector control parameters of Group d5.

& ATTENTION:

- ∅ When vector control mode is selected, it is necessary to perform motor parameter identification in order to obtain correct motor parameters before initial running. Upon the completion of normal process of motor parameter identification, automatically acquired motor parameters will be stored into drive for control operation during running.
- ∅ It should be noted when vector control is selected that one drive can only be used to drive one motor. The capacity gap between the drive and the motor should not be excessively big. Added to this, the power of motor could be two classes lower or one class higher than its matching drive. Failure to comply will be most likely to result in performance degradation or abnormal working.

Group A1 User-defined Displayed Parameters

A1-00	User-defined displayed parameter 1	Range: A0-00 - U1-26	Factory default: A0-00
A1-01	User-defined displayed parameter 2	Range: A0-00 - U1-26	Factory default: A0-00
A1-02	User-defined displayed parameter 3	Range: A0-00 - U1-26	Factory default: A0-00
A1-03	User-defined displayed parameter 4	Range: A0-00 - U1-26	Factory default: A0-00
A1-04	User-defined displayed parameter 5	Range: A0-00 - U1-26	Factory default: A0-00
A1-05	User-defined displayed parameter 6	Range: A0-00 - U1-26	Factory default: A0-00
A1-06	User-defined displayed parameter 7	Range: A0-00 - U1-26	Factory default: A0-00
A1-07	User-defined displayed parameter 8	Range: A0-00 - U1-26	Factory default: A0-00
A1-08	User-defined displayed parameter 9	Range: A0-00 - U1-26	Factory default: A0-00
A1-09	User-defined displayed parameter 10	Range: A0-00 - U1-26	Factory default: A0-00
A1-10	User-defined displayed parameter 11	Range: A0-00 - U1-26	Factory default: A0-00

A1-11	User-defined displayed parameter 12	Range: A0-00 - U1-26	Factory default: A0-00
A1-12	User-defined displayed parameter 13	Range: A0-00 - U1-26	Factory default: A0-00
A1-13	User-defined displayed parameter 14	Range: A0-00 - U1-26	Factory default: A0-00
A1-14	User-defined displayed parameter 15	Range: A0-00 - U1-26	Factory default: A0-00
A1-15	User-defined displayed parameter 16	Range: A0-00 - U1-26	Factory default: A0-00
A1-16	User-defined displayed parameter 17	Range: A0-00 - U1-26	Factory default: A0-00
A1-17	User-defined displayed parameter 18	Range: A0-00 - U1-26	Factory default: A0-00
A1-18	User-defined displayed parameter 19	Range: A0-00 - U1-26	Factory default: A0-00
A1-19	User-defined displayed parameter 20	Range: A0-00 - U1-26	Factory default: A0-00

A1-00 - A1-19 set values would not take effect unless A0-01 is set to 2

Setting range of thousands place: A, b, C, d, E, F, H, L, U

Setting range of hundreds place: 0 - 9;

Setting range of decade: 0 - 9;

Setting range of unit's place: 0 - 9.

Example:

To exclusively display function codes A0-00, A0-01, b0-01, E0-01 and F0-01, it is merely necessary to set A1-00 to b0-01, A1-01 to E0-01, A1-02 to F0-01 and A1-03 - A1-19 to 00.00 and then set A0-01 to 2.

A1-20	Parameter group display /hide characteristic 1	Range: 0000 - FFFF	Factory default: FFFF
A1-21	Parameter group display /hide characteristic 2	Range: 0000 - FFFF	Factory default: FFFF

When A0-01 is set to '0' to display all parameters, only the parameters whose bit corresponding to A1-20 and A1-21 is 1 can be displayed.

The parameters that correspond to bit 15 (the highest bit of binary system) - bit 0 (the lowest bit of binary system) of A1-20 are shown as table 6-2.

Table 6-2

bit15	bit14	bit13	bit12	bit11	bit10	bit9	bit8
d6	d5	d4	d3	d2	d1	d0	C4
bit7	bit6	bit5	bit4	bit3	bit2	bit1	bit0
C3	C2	C1	C0	b2	b1	b0	A0

The parameters that correspond to bit 15 (the highest bit of binary system) - bit 0 (the lowest bit of binary system) of A1-21 are shown as follows:

Table 6-3

bit15	bit14	bit13	bit12	bit11	bit10	bit9	bit8
reserved	reserved	L1	L0	H2	H1	H0	F6
bit7	bit6	bit5	bit4	bit3	bit2	bit1	bit0
F5	F4	F3	F2	F1	F0	E1	E0

& ATTENTION:

Parameters of Groups A1, U0, U1 and U2 are always displayed and are not subject to A1-20 and A1-21 show/hide control.

Example:

Besides parameter Groups A1, U0, U1 and U2, the groups b0, b1, b2, C0, C1, C2, C3, d0, d1 and E1 are also requested to display, just set:

A1-20 to 06FE (A1-20 is 0000 0110 1111 1110 in binary)

A1-21 to 0002 (A1-21 is 0000 0000 0000 0010 in binary)

Group b Setting of Running Parameters

Group b0 Frequency Command

Frequency command is set by parameter Group b0. See Fig. 6-1 for logical relation of frequency command.

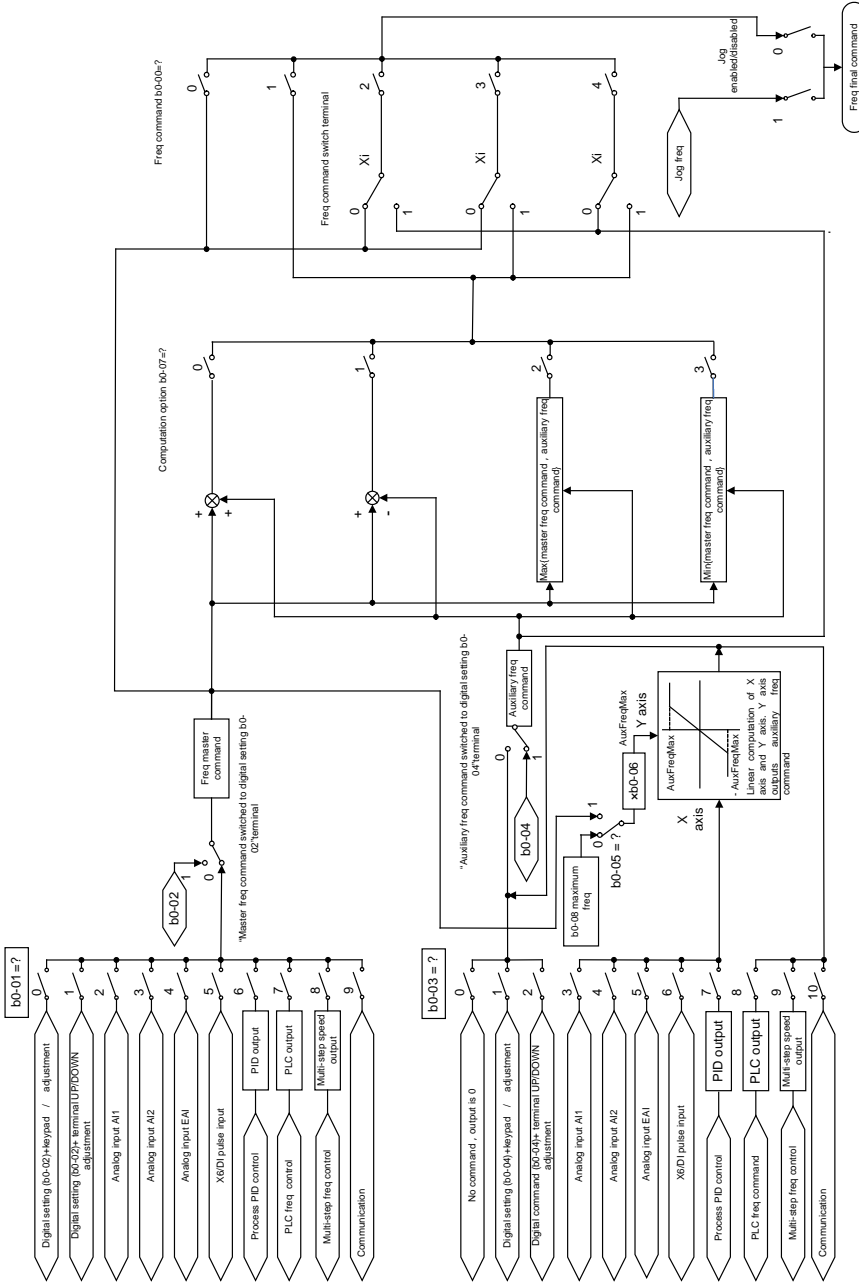

Fig. 6-1

b0-00	Frequency command pattern	Range: 0 - 4	Factory default: 0
-------	---------------------------	--------------	-----------------------

0: Master frequency command

Output frequency of drive is determined by master frequency command source b0-01. Refer to parameters b0-01 and b0-02 for further information.

1: Master & auxiliary computation result

Frequency command is the result of master & auxiliary computation. The master & auxiliary computation relation is determined by b0-07. Main command is set by b0-01, while auxiliary is set by b0-03.

2: Switch between master frequency command, and auxiliary frequency command

When b0-00 is set to 2, the switch between master frequency command, and master & auxiliary computation result can be realized through digital input terminal "frequency command switchover". When terminal "frequency command switchover" is invalid, command frequency of the drive will be determined by b0-01. When terminal "frequency command switchover" is valid, command frequency of the drive will be determined by b0-03 (Auxiliary frequency command source).

3: Switch between master frequency command, and master & auxiliary computation result

When b0-00 is set to 3, command frequency will be determined by master frequency command, or master & auxiliary computation result through digital input terminal "frequency command switchover". When terminal "frequency command switchover" is invalid, command frequency is determined by b0-01 (master frequency command source). When terminal "frequency command switchover" is valid, command frequency is determined by master & auxiliary computation result. The master & auxiliary computation relation is determined by b0-07.

4: Switch between auxiliary frequency command, and master & auxiliary computation result

When b0-00 is set to 4, command frequency will be determined by auxiliary frequency command, or master & auxiliary computation result through digital input terminal "frequency command switchover". When terminal "frequency command switchover" is invalid, command frequency is determined by b0-03 (auxiliary frequency command source). When terminal "frequency command switchover" is valid, command frequency is determined by master & auxiliary computation result. The master & auxiliary computation relation is determined by b0-07.

b0-01	Master frequency command source	Range: 0 - 9	Factory default: 0
-------	---------------------------------	--------------	-----------------------

0: Digital setting (b0-02) + \wedge / \vee adjustment on keypad

When the drive is powered up, the value of b0-02 is taken as the master frequency command which can be adjusted through \wedge / \vee keys on keypad no matter the drive is running or in stop.

& ATTENTION:

Frequency adjustment via \wedge / \vee on keypad can be cleared through terminal "UP/DOWN (including \wedge / \vee key) adjustment clear". Refer to C0-01 - C0-10 for details.

1: Digital setting (b0-02) + terminal UP/DOWN adjustment

When the drive is powered up, the value of b0-02 is taken as the master frequency command. This frequency can be adjusted via "terminal UP" and "terminal DOWN" no matter the drive is running or in stop.

When this parameter value is selected, following parameter setting should be performed:

- 1) Set the two digital input terminals to "terminal UP" and "terminal DOWN" respectively.
Refer to C0-01 - C0-10 for further information.
- 2) Set terminal UP/DOWN frequency change step size (C0-18).
- 3) Set C0-17 (terminal UP/DOWN frequency adjustment treatment).

& ATTENTION:

Frequency adjustment via terminal UP and DOWN can be cleared through terminal "UP/DOWN (including \wedge / \vee key) adjustment clear". Refer to C0-01 - C0-10 for details.

2: Analogue input AI1

(0 - 10V) voltage input and (0 - 20mA) current input are optional for AI1, which can be selected using toggle switch S2 on control board.



Fig. 6-2

Refer to specification of C2-00 - C2-20 for corresponding relation between analogue input and output frequency.

See parameter Group C4 for automatic correction of analogue quantity input.

3: Analogue input AI2

AI2 input is the -10V to +10V voltage input, and the plus-minus of voltage determines the setting direction of frequency.

Refer to detailed description of C2-00 - C2-20 for corresponding relation between analogue quantity and frequency.

See function codes of Group C4 for automatic correction of analogue input.

4: Analogue input EAI (on IO expansion board)

Terminal EAI is located at IO expansion board, supporting 0 - 10V voltage input and 0 - 20mA current input. It can be used with the same way as AI1.

When using external voltage/current analogue input to the drive, the connection diagram is shown as Fig. 6-3:

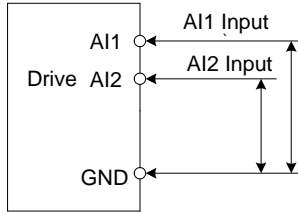

Fig. 6-3

If 10V power supply inside the drive is used with potentiometer, the connection diagram is shown as Fig. 6-4. Note that the toggle switch should be switched to voltage input side.

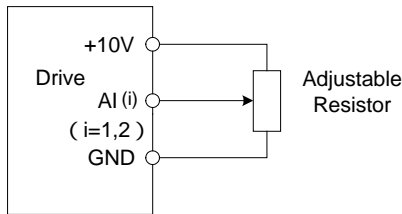

Fig. 6-4

5: X6/DI pulse input

If this parameter value selected, command frequency will be determined by pulse frequency input via terminal X6/DI only. In such a case, C0-06 should be set to 24. Corresponding relation between pulse frequency and command frequency is specified in C2-24 - C2-27.

6: Process PID output

Command frequency is determined by process closed-loop PID computation result. See parameter Group F0 for details.

7: PLC

Command frequency is determined by simple PLC. See parameter Group F2 for details.

8: Multi-step speed

A total of 16-step speed settings can be realized through status combination of "multi-step frequency terminal 1 - 4". See the table below for details. Command frequency can be switched via different combination of multi-step frequency terminals no matter in running or in

stop.

Table 6-4

Multi-step frequency terminal 4	Multi-step frequency terminal 3	Multi-step frequency terminal 2	Multi-step frequency terminal 1	Command Frequency
OFF	OFF	OFF	OFF	Multi-step frequency 0 (F1-00)
OFF	OFF	OFF	ON	Multi-step frequency 1 (F1-01)
OFF	OFF	ON	OFF	Multi-step frequency 2 (F1-04)
OFF	OFF	ON	ON	Multi-step frequency 3 (F1-05)
OFF	ON	OFF	OFF	Multi-step frequency 4 (F1-06)
OFF	ON	OFF	ON	Multi-step frequency 5 (F1-07)
OFF	ON	ON	OFF	Multi-step frequency 6 (F1-08)
OFF	ON	ON	ON	Multi-step frequency 7 (F1-09)
ON	OFF	OFF	OFF	Multi-step frequency 8 (F1-10)
ON	OFF	OFF	ON	Multi-step frequency 9 (F1-11)
ON	OFF	ON	OFF	Multi-step frequency 10 (F1-12)
ON	OFF	ON	ON	Multi-step frequency 11 (F1-13)
ON	ON	OFF	OFF	Multi-step frequency 12 (F1-14)
ON	ON	OFF	ON	Multi-step frequency 13 (F1-15)
ON	ON	ON	OFF	Multi-step frequency 14 (F1-16)
ON	ON	ON	ON	Multi-step frequency 15 (F1-17)

9: Communication

Upper computer is the master frequency command source of the drive through standard RS485 communication interface on the drive..

refer to Group H0 and appendix on this manual for further information about

communication protocol, and programming, etc.

& ATTENTION:

Master frequency command can be forcibly switched to b0-02 via terminal "master frequency command switched to digital setting b0-02". When this terminal is disabled, master frequency command is determined by b0-01. When terminal is enabled, master frequency command shall be the value of b0-02.

b0-02	Digital setting of master frequency	Range: lower limit frequency - upper limit frequency	Factory default: 50.00Hz
-------	-------------------------------------	--	--------------------------

When master frequency command source b0-01 is set to either 0 or 1, this parameter value will be the initial value of master frequency command.

b0-03	Auxiliary frequency command source	Range: 0 - 10	Factory default: 0
-------	------------------------------------	---------------	--------------------

0: No command

Auxiliary frequency command is disabled, and auxiliary frequency is 0.

1: Digital setting (b0-04) + / adjustment on keypad

When the drive is powered up, the value of b0-04 is auxiliary frequency command, also can be adjusted through \wedge / \vee on keypad no matter the drive is running or in stop status.

& ATTENTION:

When master frequency command involves \wedge / \vee adjustment on keypad, \wedge / \vee involving auxiliary frequency command shall be disabled.

2: digital setting (b0-04) + terminal UP/DOWN adjustment

When the drive is powered up, the value of b0-04 is current auxiliary frequency command. Whether the drive is running or stopped, current auxiliary frequency setting can be adjusted through digital input terminals "UP" and "DOWN". Just set "terminal UP/DOWN frequency adjustment treatment" and "terminal UP/DOWN frequency change step size" through C0-17 and C0-18.

& ATTENTION:

When master frequency command involves terminal UP/DOWN adjustment, UP/DOWN adjustment involving auxiliary frequency command shall be disabled.

3: Analogue input AI1

4: Analogue input AI2

5: Analogue input EAI (on IO expansion board)

AI1 and EAI can be either (0 - 10V) voltage input or (0 - 20mA) current input which can be switched by the toggle switch on control board or IO expansion board. AI2 input is -10V to

+10V input only, and the plus/minus of the voltage determines the direction of motor running.

& ATTENTION:

- Ø When analogue input channel of auxiliary frequency command is the same with that of master frequency command, analogue input channel of auxiliary frequency command would be disabled.
- Ø See b0-05 and b0-06 for information, about frequency relation that corresponds to maximum value of analogue input of auxiliary frequency command.

6: X6/DI pulse input

Auxiliary frequency command is determined by pulse frequency via terminal X6/DI only. In such a case, set X6/DI terminal to "pulse input"(set C0-06 to 24). Refer to C2-24 - C2-27 for corresponding relationship between pulse frequency and command frequency.

& ATTENTION:

- Ø In case X6/DI pulse input is also set for master frequency command source, the pulse input for auxiliary frequency command shall be disabled.
- Ø See b0-05 and b0-06 for information about frequency relation that corresponds to maximum value of pulse input for auxiliary frequency command.

7: Process PID output

Auxiliary frequency command is determined by process PID computation result. See parameter Group F0 for details.

& ATTENTION:

- Ø In case PID output is also set for master frequency command, the process PID output for auxiliary frequency command would be disabled.
- Ø See b0-05 and b0-06 for information about frequency relation that corresponds to maximum value of process PID output for auxiliary frequency command.

8: PLC

Auxiliary frequency command is determined by simple PLC. See parameter Group F2 for details.

& ATTENTION:

In case simple PLC program output is also set for master frequency command, the PLC for auxiliary frequency command would be disabled.

9: Multi-step speed

A total of 16-step speed settings can be realized through status combination of "multi-step frequency terminal 1 - 4". Command frequency can be switched via different combination of multi-step frequency terminals no matter in running or in stop.

& ATTENTION:

In case master frequency command is also set to multi-step speed, the multi-step speed output for auxiliary frequency setting would be disabled.

10: Communication

Upper computer is the auxiliary frequency command source of the drive through standard RS485 communication interface on the drive. Refer to Group H0 and appendix on this manual for further information about communication protocol, and programming, etc.

& ATTENTION:

Auxiliary frequency command can be forcibly switched to b0-04 via terminal "auxiliary frequency command switched to digital setting b0-04". When this terminal is disabled, master frequency command is determined by b0-03. When terminal is enabled, master frequency command shall be the value of b0-04.

b0-04	Digital setting of auxiliary frequency	Range: lower limit frequency - upper limit frequency	Factory default: 0.00Hz
-------	--	--	-------------------------

When auxiliary frequency command is set to either 1 or 2, this parameter value should be the initial value of auxiliary frequency command.

b0-05	Range of auxiliary frequency	Range: 0 - 1	Factory default: 0
-------	------------------------------	--------------	--------------------

0: Relative to maximum frequency

1: Relative to master frequency

See b0-06 specification for details.

b0-06	Coeff of auxiliary frequency command	Range: 0.0% - 100.0%	Factory default: 100.0%
-------	--------------------------------------	----------------------	-------------------------

When b0-03 selects AI1, AI2, EAI, X6/DI pulse input, or process PID output as auxiliary frequency command sources, b0-05 and b0-06 will determine the final output value of auxiliary frequency command.

When b0-05 is set to 0 (relative to maximum frequency):

When AI1, AI2, EAI, X6/DI pulse input is selected for auxiliary frequency command, the frequency that corresponds to maximum value of the source should be (b0-08×b0-06).

Example:

Select AI1 as auxiliary frequency command source (set b0-03 to 3) and set AI1 to curve 1 (unit's place of C2-00 is 0) as shown in Fig. 6-5. In such a case, the frequency that corresponds to the maximum input of curve 1 should be: (C2-02) × [(b0-08) × (b0-06)].

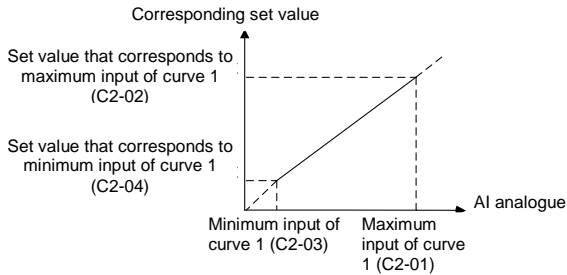

Fig. 6-5

When X6/DI pulse input is selected as auxiliary frequency command (set b0-03 to 6), the frequency that corresponds to maximum DI input should be: $(C2-25) \times [(b0-08) \times (b0-06)]$.

When PID is selected for auxiliary frequency command, the frequency that corresponds to maximum value of PID output should be $(b0-08) \times (b0-06)$.

PID output diagrammatic sketch is as shown in Fig. 6-6.

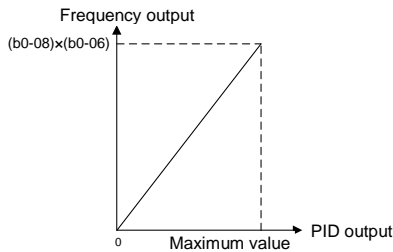

Fig. 6-6

When b0-05 is set to 1 (relative to master frequency):

When AI1, AI2, EAI, or X6/DI pulse input is selected for auxiliary frequency command source, the frequency that corresponds to maximum value of these sources should be: $[\text{master frequency} \times (b0-06)]$.

Example:

When selecting AI1 as auxiliary frequency command source (set b0-03 to 3) and setting AI1 to curve 1 (unit's place of C2-00 is 0), the frequency that corresponds to maximum input of curve 1 should be: $(C2-02) \times [\text{master frequency} \times (b0-06)]$.

When X6/DI pulse input is selected as auxiliary frequency command source (set b0-03 to 6), the frequency that corresponds to maximum DI input should be: $(C2-25) \times [\text{master frequency} \times (b0-06)]$.

When PID is selected for auxiliary frequency command, the frequency that corresponds to maximum value of PID output should be [master frequency × (b0-06)].

PID output diagram is as shown in Fig. 6-7.

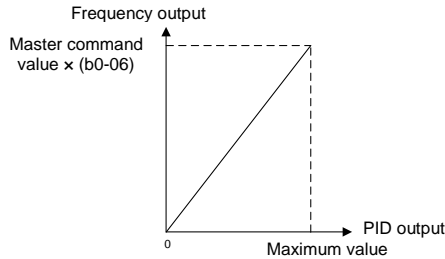

Fig. 6-7

b0-07	Computation of master and auxiliary frequency	Range: 0 - 3	Factory default: 0
-------	---	--------------	--------------------

0: Master + auxiliary

The sum of master and auxiliary frequency is taken as frequency command. Output result is subject to limitation of upper and lower limit frequency.

1: Master - auxiliary

The difference between master and auxiliary frequency is taken as frequency command. Output result is subject to limitation of upper and lower limit frequency.

2: Max {master, auxiliary}

Master frequency or auxiliary frequency (whichever has a larger absolute value) is taken as frequency command. Output result is subject to limitation of upper and lower limit frequency.

3: Min {master, auxiliary}

Master frequency or auxiliary frequency (whichever has a smaller absolute value) is taken as frequency command. Output result is subject to limitation of upper and lower limit frequency.

b0-08	Maximum frequency	Range: Upper limit frequency - 600.00Hz	Factory default: 50.00Hz
b0-09	Upper limit frequency	Range: Lower limit frequency - maximum frequency	Factory default: 50.00Hz
b0-10	Lower limit frequency	Range: 0.00Hz - upper limit frequency	Factory default: 0.00Hz

Maximum frequency of b0-08 is the maximum allowable output frequency of drive and is indicated by fmax in the figure.

B0-09 upper limit frequency is the user-defined maximum allowable running frequency and represented by fH in Fig. 6-8.

B0-10 lower limit frequency is user-defined minimum allowable running frequency and

marked with fL in Fig. 6-8.

In Fig. 6-8, fN represents rated frequency of motor while VN means the rated voltage of motor.

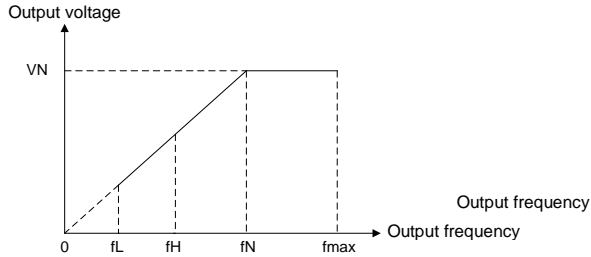

Fig. 6-8

& ATTENTION:

- Ø Maximum frequency, upper limit frequency and lower limit frequency should be set with care in accordance with nameplate parameters of motor and operation requirements.
- Ø Jog and motor parameter identification is free from limitations of upper and lower limit frequency.
- Ø In addition to limitation of upper limit frequency and lower limit frequency, the output frequency is also subject to limitations of starting frequency, stop DC brake initial frequency, skip frequency and other parameter settings.
- Ø The rank relation between maximum frequency, upper limit frequency and lower limit frequency is shown as Fig. 6-8.
- Ø Upper and lower limit frequencies restrict actual output frequency to motor. If command frequency is higher than upper limit frequency, the running would be at upper limit frequency. In case command frequency is lower than lower limit frequency, the running should be in accordance with the setting of b0-11.

b0-11	Operation when command frequency lower than lower limit frequency	Range: 0 - 2	Factory default: 0
-------	---	--------------	--------------------

0: Run at lower limit frequency

In case command frequency is lower than lower limit frequency, the running should be at lower limit frequency.

1: Run at 0Hz

In case the frequency command is lower than lower limit frequency, the running should be at 0Hz.

2: Stop

If frequency command is lower than lower limit frequency, stop would be activated after the time delay set by b0-12. When lower limit frequency is 0, this limitation is invalid.

& ATTENTION:

This parameter is disabled under PID control mode.

b0-12	Time-delay of stop when command frequency lower than lower limit frequency	Range: 0.0s - 6553.5s	Factory default: 0.0s
-------	--	-----------------------	-----------------------

When b0-11 is set to 2, and command frequency is lower than lower limit frequency, the drive will stop running after this parameter value.

b0-13	Lower limit of skip frequency band 1	Range: 0.00Hz - upper limit frequency	Factory default: 0.00Hz
b0-14	Upper limit of skip frequency band 1	Range: 0.00Hz - upper limit frequency	Factory default: 0.00Hz
b0-15	Lower limit of skip frequency band 2	Range: 0.00Hz - upper limit frequency	Factory default: 0.00Hz
b0-16	Upper limit of skip frequency band 2	Range: 0.00Hz - upper limit frequency	Factory default: 0.00Hz
b0-17	Lower limit of skip frequency band 3	Range: 0.00Hz - upper limit frequency	Factory default: 0.00Hz
b0-18	Upper limit of skip frequency band 3	Range: 0.00Hz - upper limit frequency	Factory default: 0.00Hz

Skip frequency is a function designed to prevent the drive running at resonance zone of mechanical system.

At most 3 skip zones can be defined. See Fig. 6-9.

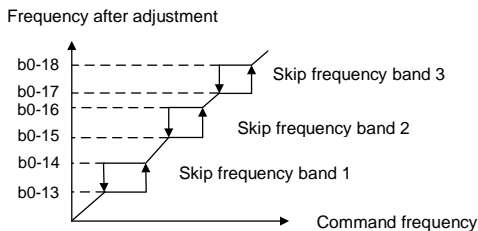

Fig. 6-9

Once parameters of skip zones are set, the output frequency of the drive would automatically get out of these skip zones even if the command frequency is within these zones.

& ATTENTION:

Output frequency of drive can normally pass through skip zones during Accel and Decel.

b0-19	Jog frequency	Range: 0.00Hz - upper limit frequency	Factory default: 5.00Hz
-------	---------------	---------------------------------------	-------------------------

This parameter sets the running frequency during jog. Jog Accel time is set by parameter b2-10 while its Decel time by parameter b2-11.

Jog run command control could be performed through keypad, control terminals or communication input.

Multifunction MF key can be set as forward jog or reverse jog key through parameter L0-00.

Jog can be realized using "forward jog terminal" and "reverse jog terminal" of DI.

Jog can be realized via communication input. See drive communication protocol for further information.

See Jog diagrammatic sketch 6-10.

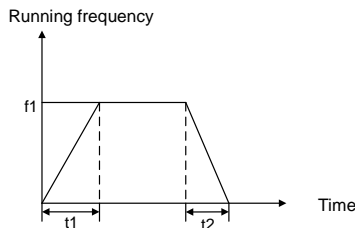

Fig. 6-10

Thereof:

f1 is jog frequency b0-19

t1 represents the ACC time from zero to jog frequency; $t1 = (b2-10) \times f1 / (b0-08)$; b0-08 is the maximum frequency.

t2 is the DEC time from jog frequency to 0; $t2 = (b2-11) \times f1 / (b0-08)$.

& ATTENTION:

- Ø Set value of jog frequency is free from limitations of upper and lower limit frequency.
- Ø Jog is started from starting frequency and its start is not subject to limitation by b1-05.

Group b1 Start/Stop Control

b1-00	Run command	Range: 0 - 2	Factory default: 0
-------	-------------	--------------	--------------------

This parameter sets run command source. Run commands include "start, stop, forward and reverse", etc.

0: Keypad control

Control run command through RUN, STOP/RESET and MF keys on keypad (set multifunction key MF to JOG by L0-00). Refer to Chapter 4 about the operation of keypad.

1: Terminal control

Control run command via DI terminals. Perform FORWARD and REVERSE by DI terminals.

The control mode are two-wire mode and three-wire mode selectable. See Group C0 for details of designation and wiring regulation of DI terminals.

2: Communication control

Master device is able to control run command through built-in RS485 serial communication interface of drive. Refer to parameters Group H0 and appendix for further information about programming.

Run command from keypad, terminals and communication can be switched by terminals "run command switched to keypad control", "run command switched to terminal control" and "run command switched to communication control".

Multifunction key MF can be set to "run command sources shifted" key through parameter L0-00. When MF key is pressed under this setting, run command will be shifted during keypad control, terminal control and communication control circularly.

b1-01	Binding of run command and frequency command	Range: 000 - AAA	Factory default: 000
-------	--	------------------	----------------------

This parameter defines the bundled combination of three run command sources and frequency command sources with the purpose of facilitating simultaneous switching.

For example: frequency command source AI1 (unit's place of b1-01 is set to 3) bundled with keypad control, while the frequency command source X6/DI pulse input (ten's place of b1-01 is set to 6) bundled with terminal control. In such a case, when run command is controlled by keypad, frequency command source would be AI1, while when run command is controlled via terminals, frequency command source will be automatically switched to X6/DI pulse input.

U Unit's place: frequency command source bundled under keypad control

0: No binding

1: Digital setting (b0-02) + \wedge / \vee adjustment on keypad

2: Digital setting (b0-02) + terminal UP/DOWN adjustment

3: Analogue input AI1

4: Analogue input AI2

5: Analogue input EAI (on IO expansion board)

6: X6/DI pulse input

7: Process PID output

8: Simple PLC

9: Multi-step frequency

A: Communication input

Refer to parameter b0-01 for details regarding above-mentioned sources of frequency command.

U Decade: frequency command source bundled under terminal control (same as unit's place)

U Hundreds place: frequency command source bundled under communication control (same as unit's place)

& ATTENTION:

Ø Different run command sources can be bundled with the same frequency command source.

Ø The priority of frequency command sources bundled with run command overrides Group b0.

b1-02	Running direction	Range: 0 - 1	Factory default: 0
-------	-------------------	--------------	--------------------

This parameter applies to run command controlled by keypad, and disabled under terminal and communication control.

0: Forward

1: Reverse

b1-03	Reverse disabled	Range: 0 - 1	Factory default: 0
-------	------------------	--------------	--------------------

0: Reverse enabled

1: Reverse disabled

In some applications, reverse is likely to result in equipment damage. This parameter is used to prevent reverse running.

b1-04	Dead time of forward and reverse	Range: 0.0s - 3600.0s	Factory default: 0.0s
-------	----------------------------------	-----------------------	-----------------------

The dead time with 0Hz output during the transition from forward to reverse, or from reverse to

forward is indicated by letter "t" in Fig. 6-11.

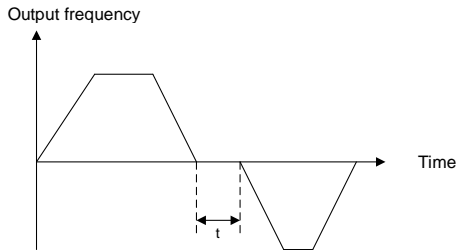

Fig. 6-11 Dead time between forward and reverse

b1-05	Start method	Range: 0 - 2	Factory default: 0
-------	--------------	--------------	--------------------

This parameter takes effect during the process of transition from stop status to running status.

0: From start frequency

When drive starts to run from stop status, it starts from start frequency (b1-06) and keeps this frequency for a period of time set by b1-07, and then accelerated to command frequency in accordance with the Accel method and time.

1: DC braking then start

To make the motor stop completely, the drive will perform DC braking with a certain period of time, as specified by b1-08 and b1-09, then start from start frequency (b1-06), keeping a period of time as specified by b1-07, and then Accelerate to command frequency.

2: Start based on speed search

Search the actual speed of motor that is rotating and perform smooth start from the searched speed. This start method is applicable to restart on momentary power loss, the start of fan which is still rotating, etc. To assure the accuracy of speed search, please correctly set motor parameters, and b1-10 - b1-12.

b1-06	Start frequency	Range: 0.00Hz - upper limit frequency	Factory default: 0.00Hz
b1-07	Holding time of start frequency	Range: 0.0s - 3600.0s	Factory default: 0.0s

Start frequency is initial output frequency of drive start from stop status. Start frequency holding time is the continuous running time with start frequency. After this holding time, the drive will Accelerate to command frequency. Usually appropriate start frequency and holding time assure the starting torque of heavy-duty load.

& ATTENTION:

Provided that command frequency is lower than start frequency, drive output frequency is 0 Hz. Start frequency also works on the transition of forward and reverse, but starting frequency

holding time is disabled during transition between forward and reverse. Accel time of Group b2 excludes holding time of start frequency.

b1-08	DC braking current when start	Range: 0.0% - 100.0%	Factory default: 0.0%
b1-09	DC braking time when start	Range: 0.00s - 30.00s	Factory default: 0.00s

When the motor is started by the method "DC braking then start", it is essential to set these two parameters. 100% corresponds to rated current of drive. If braking time is set to 0.0s, DC braking when start shall be disabled.

b1-10	Speed search current	Range: 0 - 200.0%	Factory default: 100.0%
-------	----------------------	-------------------	-------------------------

100% corresponds to rated current of the drive. When output current of drive is less than this parameter value, it will be deemed that the output frequency of drive has been kept in step with motor speed and the search action finished.

b1-11	Speed search Decel time	Range: 0.1s - 20.0s	Factory default: 2.0s
-------	-------------------------	---------------------	-----------------------

This parameter sets the output frequency Decel time of speed search action. This time means the time required for Decel from maximum frequency to 0. The shorter the speed search Decel time is, the faster the search will be. However, excessively rapid search may bring about inaccuracy of search result.

b1-12	V/f coefficient during speed search	Range: 20.0% - 100.0%	Factory default: 100.0%
-------	-------------------------------------	-----------------------	-------------------------

This parameter is set to suppress the output current of speed search, and improve the reliability of speed search, by multiplying this value on the basis of motor V/f curve.

b1-13	Stop method	Range: 0 - 2	Factory default: 0
-------	-------------	--------------	--------------------

0: Ramp to stop

Upon the receipt of stop command, drive will gradually decrease output frequency according to the set Decel time, and stop when frequency attains 0.

1: Coast to stop

Upon the receipt of stop command, drive will immediately lock the output and the motor will stop with its mechanical inertia.

2: Ramp to stop + DC brake

Upon the receipt of stop command, drive will decrease output frequency in accordance with the rate of Decel time setting. Once the output frequency attains set value of b1-14, DC braking will be enabled, and the drive will stop after the finish of DC braking.

b1-14	Start frequency of DC brake stop	Range: 0.00Hz - upper limiting frequency	Factory default: 0.00Hz
b1-15	DC brake current	Range: 0.0% - 100.0%	Factory default: 0.0%
b1-16	DC brake time	Range: 0.00s - 30.00s	Factory default: 0.00s

During the process “ramp to stop + DC braking”, DC brake would be started when output frequency attains set value of b1-14. b1-15 defines brake level, in amps, applied to the motor. 100% corresponds to rated current of drive. B1-16 sets the length of time that DC brake current is “injected” into the motor when b1-13 is set to 2. In case brake time is set to 0.0s, DC brake shall be disabled.

If "DC brake stop" terminal enabled, time length of this terminal or b1-16 set time (whichever is longer) would be taken as stop brake time.

b1-17	Overexcitation brake	Range: 0 - 1	Factory default: 1
-------	----------------------	--------------	--------------------

0: Disabled

1: Enabled

When overexcitation brake is enabled in case of stop by Decel, the motor shall transform the electric energy generated during Decel into heat energy by increasing magnetic flux so as to attain rapid stop. If this parameter is enabled, the Decel time will be shortened. If overexcitation brake is disabled, the Decel current of motor will decrease and the Decel time will be lengthened.

b1-18	Dynamic brake	Range: 0 - 1	Factory default: 0
-------	---------------	--------------	--------------------

0: Disabled

1: Enabled

When dynamic brake is enabled, the electric energy generated during Decel shall be converted into heat energy consumed by brake resistor, so as to attain rapid Decel. This brake method applies to brake of high-inertia load or the situations that require quick stop. In such a case, it is necessary to select appropriate dynamic brake resistor and brake unit.

b1-19	Dynamic brake threshold voltage	Range: 650V - 750V	Factory default: 720V
-------	---------------------------------	--------------------	-----------------------

This parameter takes effect only to the drives with built-in brake unit.

If b1-18 is set to 1: when bus voltage of drive attains the value of b1-19, dynamic brake shall perform. The energy shall be rapidly consumed through brake resistor. This value is used to regulate the brake effect of brake unit.

b1-20	Auto restart when power up again after power loss	Range: 0 - 1	Factory default: 0
-------	---	--------------	--------------------

Defines the drive status when power up again after power loss during running

0: Disabled

The drive will not run automatically when power is up after power loss.

1: Enabled.

When run command is controlled by keypad or communication, the drive will run automatically when power is up again after power loss. When run command is controlled by terminals, the drive will run automatically only if ON signal from run command terminal is detected

& ATTENTION:

Enable this parameter with caution for safety consideration.

b1-21	Waiting time of auto restart when power up again	Range: 0.0s - 10.0s	Factory default: 0.0s
-------	--	---------------------	-----------------------

This time setting is on the basis of work restoration time of relative devices in the system when power is up again after power loss, if b1-20 is set to 1.

Group b2 Accel/Decel Parameters

b2-00	Accel/Decel time resolution	Range: 0 - 2	Factory default: 1
-------	-----------------------------	--------------	--------------------

0: 0.01s; the setting range of Accel/Decel time is 0.00s - 600.00s

1: 0.1s; the setting range of Accel/Decel time is 0.0s - 6000.0s

2: 1s; the setting range of Accel/Decel time is 0s - 60000s

Accel/Decel time resolution takes effect on b2-01 - b2-11.

b2-01	Accel time 1	Range: 0s - 60000s	Factory default: 6.0s
b2-02	Decel time 1	Range: 0s - 60000s	Factory default: 6.0s
b2-03	Accel time 2	Range: 0s - 60000s	Factory default: 6.0s
b2-04	Decel time 2	Range: 0s - 60000s	Factory default: 6.0s
b2-05	Accel time 3	Range: 0s - 60000s	Factory default: 6.0s
b2-06	Decel time 3	Range: 0s - 60000s	Factory default: 6.0s
b2-07	Accel time 4	Range: 0s - 60000s	Factory default: 6.0s

b2-08	Decel time 4	Range: 0s - 60000s	Factory default: 6.0s
-------	--------------	--------------------	--------------------------

These parameters b2-01 - b2-08 set the rate of Accel/Decel for speed increase/decrease.

Maximum Freq (b0-08) / Accel time X = Accel Rate X

Maximum Freq (b0-08) / Decel time X = Decel Rate X

As the formula sets forth above, Accel time means required time for drive to Accelerate to maximum frequency b0-08 from zero frequency, while Decel time refers to the time required for drive to Decelerate to zero frequency from maximum frequency b0-08.

These four types of Accel/Decel time can be selected through the ON/OFF combination of DI terminals" Accel/Decel time determinant 1" and " Accel/Decel time determinant 2". See Table 6-5.

Table 6-5

Accel/Decel time determinant 2	Accel/Decel time determinant 1	Accel/Decel time
OFF	OFF	Accel/Decel time 1(b2-01, b2-02)
OFF	ON	Accel/Decel time 2(b2-03, b2-04)
ON	OFF	Accel/Decel time 3(b2-05, b2-06)
ON	ON	Accel/Decel time 4(b2-07, b2-08)

& ATTENTION:

- ∅ When the drive is running under simple PLC, the Accel time and Decel time are determined by simple PLC related parameters, not by the DI terminals. See Group F2 for details.
- ∅ When Accel/Decel of broken-line style is selected, Accel/Decel time is automatically switched to Accel/Decel time 1 and 2 according to switching frequency (b2-13 and b2-14). Under this circumstance, Accel/Decel time selection terminals are disabled.

b2-09	Decel time for emergency stop	Range: 0s - 60000s	Factory default: 6.0s
-------	-------------------------------	--------------------	--------------------------

In case of emergency stop via multifunction MF key on keypad (MF key has been set to emergency stop 1 through parameter L0-00), or via DI terminal "emergency stop", Decel is conducted according to this time. This parameter sets the rate of Decel for speed decrease, similar with b2-01 - b2-08.

b2-10	Jog Accel time	Range: 0s - 60000s	Factory default: 6.0s
-------	----------------	--------------------	--------------------------

b2-11	Jog Decel time	Range: 0s - 60000s	Factory default: 6.0s
-------	----------------	--------------------	-----------------------

b2-10 and b2-11 set the rate of Accel/Decel of Jog, similar with b2-01 - b2-08.

b2-12	Accel/Decel curve	Range: 0 - 4	Factory default: 0
-------	-------------------	--------------	--------------------

0: Linear Accel/Decel

Outputs frequency increases or decreases with a constant rate as shown in Fig. 6-12.

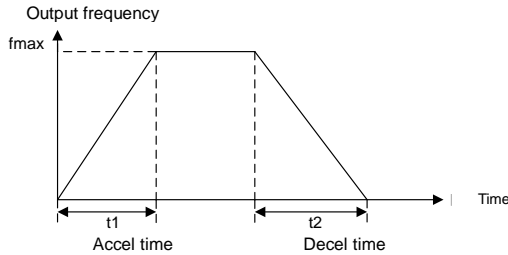

Fig. 6-12

fmax is maximum frequency b0-08.

1: Broken-line Accel/Decel

Accel/Decel time is shifted based on output frequency during Accel/Decel.

When output frequency during Accel is higher than or equal to b2-13 (Accel time switching frequency of broken-line Accel/Decel), b2-01 (Accel time 1) is enabled. When lower than b2-13, b2-03 (Accel time 2) will be enabled.

When output frequency during Decel is higher than or equal to b2-14 (Decel time switching frequency of broken-line Accel/Decel), b2-02 (Decel time 1) is enabled. When lower than b2-14, b2-04 (Decel time 2) will be enabled.

& ATTENTION:

When broken-line Accel/Decel is enabled, " Accel/Decel time determinant 1" and " Accel/Decel time determinant 2" will be disabled.

Broken-line Accel/Decel is as shown in Fig. 6-13.

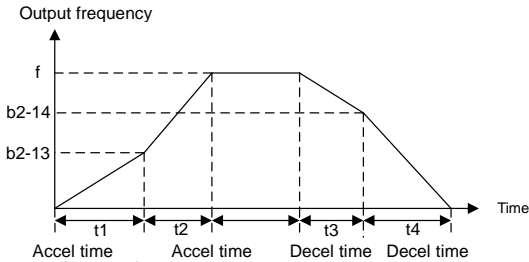

Fig. 6-13

$$t1 = (b2-03) \times (b2-13) / (b0-08) \qquad t2 = (b2-01) \times [f - (b2-13)] / (b0-08)$$

$$t3 = (b2-02) \times [f - (b2-14)] / (b0-08) \qquad t4 = (b2-04) \times (b2-14) / (b0-08)$$

f is current frequency command, and b0-08 is maximum frequency.

2: S-curve Accel/Decel A

By adding a period of S-curve to the initial and ending segments of Accel/Decel, it can improve the smoothness of start/stop and prevent mechanical impact. See Fig. 6-14:

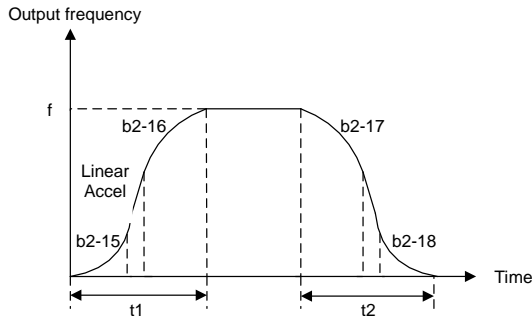

Fig. 6-14

Accel/Decel rate changes gradually at the initial and ending segments of S-curve time. At the middle segment of S-curve, it is linear Accel/Decel rate, which is determined by enabled Accel/Decel time 1 - 4. Therefore, the actual Accel/Decel time is longer than linear Accel/Decel if this parameter value is selected.

$$\text{Actual Accel time} = \text{linear Accel time} + (\text{Time of initial segment of Accel S-curve} + \text{Time of last segment of Accel S-curve})/2$$

$$\text{Actual Decel time} = \text{linear Decel time} + (\text{Time of initial segment of Decel S-curve} + \text{Time of last segment of Decel S-curve})/2$$

Example:

Assuming that the maximum frequency b0-08 is 50Hz and the Accel time set is 6s, the linear

Accel time from initial status 10Hz to 40Hz = $6s \times (40\text{Hz}-10\text{Hz})/50\text{Hz} = 3.6s$

Assuming $b2-15 = 0.20s$ and $b2-16 = 0.40s$, the actual Accel time under "S-curve Accel/Decel A" = $3.6s + (0.20s + 0.40s)/2 = 3.9s$.

& ATTENTION:

Provided the above-noted calculated linear Accel time is less than $(\text{Time of initial segment of Accel S-curve} + \text{Time of last segment of Accel S-curve})/2$, there will not be linear part.

Decel is the same as above.

3: S-curve Accel/Decel B

Schematic diagram is shown as Fig. 6-15:

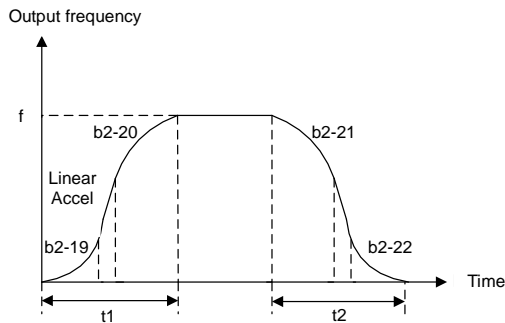

Fig. 6-15

S-curve time at initial segment of Accel is $(b2-19 \times t1)$ in the figure, in which the Accel rate increases progressively. In this period, the S-curve time at ending segment is $(b2-20 \times t1)$ and the Accel rate decreases gradually. At the middle of $t1$, it is linear Accel with a constant rate which is adjusted automatically based on the setting of $b2-19$ and $b2-20$.

Decel period $t2$ is similar as above.

Make sure the sum of proportions of initial and ending segments is no more than 100%, i.e. the sum of set values of $b2-19$ and $b2-20$ should not exceed 100.0%, while that of $b2-21$ and $b2-22$ should not exceed 100%.

Example:

Assuming that the maximum frequency b0-08 is 50Hz and the Accel time setting is 6s, the linear Accel time required for Accel from initial status 10Hz to 40Hz = $6s \times (40Hz-10Hz)/50Hz = 3.6s$

Assuming that b2-19 = 20.0% and b2-20 = 30.0%,

Initial segment of Accel S-curve should be $20.0\% \times 3.6s = 0.72s$; Ending segment of Accel S-curve should be $30.0\% \times 3.6s = 1.08s$; linear Accel time at middle segment should be $3.6s - 0.72s - 1.08s = 1.8s$.

Difference between S-curve Accel/Decel A and B:

Middle-segment Accel/Decel rate of S-curve Accel/Decel A is determined by the selected Accel/Decel time 1 - 4, not subject to the effect of S-curve time span, therefore the total Accel/Decel time changes with the variation of setting of S-curve time.

When some certain Accel/Decel time is selected for S-curve Accel/Decel B, the total time of Accel/Decel is constant, but with different proportion of initial part and ending part, the rate of linear part as well as the shape of S-curve will changes.

4: S-curve Accel/Decel C

The rated frequency of the motor is taken as inflection point of this S-curve, and the set Accel/Decel time is:

$$\text{Accel/Decel rate} = \text{Motor rated frequency} / \text{Accel/Decel time} \quad ()$$

$$\text{NOT Accel/Decel rate} = \text{Maximum frequency} / \text{Accel/Decel time} \quad (\times)$$

When command frequency is higher than rated frequency of motor, the Accel/Decel time is automatically adjusted by reducing output torque of the motor. This is applicable to the situation in which short Accel/Decel time is required during the speed range higher than rated frequency of the motor.

Diagram of S-curve C is shown as Fig. 6-16:

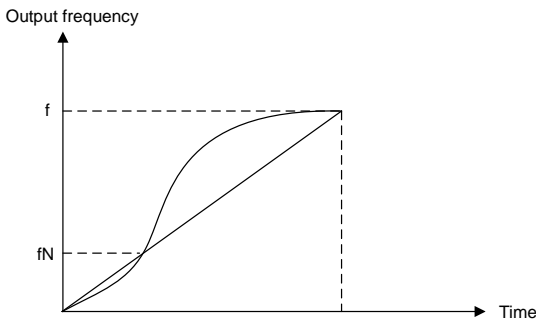

Fig. 6-16

f: Command Freq

fN: Rated Freq of the motor

b2-13	Accel time switching frequency of broken-line Accel/Decel	Range: 0.00Hz - maximum frequency	Factory default: 1.00Hz
b2-14	Decel time switching frequency of broken-line Accel/Decel	Range: 0.00Hz - maximum frequency	Factory default: 1.00Hz

When b2-12 is set to 1:

b2-01 (Accel time 1) is enabled when output frequency during Accel is more than or equal to set value of b2-13, while b2-03 (Accel time 2) is enabled when output frequency during Accel is less than set value of b2-13.

b2-02 (Decel time 1) is enabled when output frequency during Decel is more than or equal to set value of b2-14, while b2-04 (Decel time 2) is enabled when output frequency during Accel is less than set value of b2-14.

& ATTENTION:

When broken-line Accel/Decel is selected, terminals "Accel/Decel time determinant 1" and "Accel/Decel time determinant 2" will be disabled.

b2-15	Time of initial segment of Accel S-curve	Range: 0.00s - 60.00s	Factory default: 0.20s
b2-16	Time of last segment of Accel S-curve	Range: 0.00s - 60.00s	Factory default: 0.20s
b2-17	Time of initial segment of Decel S-curve	Range: 0.00s - 60.00s	Factory default: 0.20s
b2-18	Time of last segment of Decel S-curve	Range: 0.00s - 60.00s	Factory default: 0.20s

These four parameters are enabled when b2-12 is set to 2.

b2-19	Proportion of initial segment of Accel S-curve	Range: 0.0% - 100.0%	Factory default: 20.0%
b2-20	Proportion of last segment of Accel S-curve	Range: 0.0% - 100.0%	Factory default: 20.0%
b2-21	Proportion of initial segment of Decel S-curve	Range: 0.0% - 100.0%	Factory default: 20.0%
b2-22	Proportion of last segment of Decel S-curve	Range: 0.0% - 100.0%	Factory default: 20.0%

These four parameters are enabled when b2-12 is set to 3.

& ATTENTION:

The sum of set values of b2-19 and b2-20 should not exceed 100.0%. The same to b2-21 and b2-22.

Group C Input and Output Terminals

Group C0 Digital Input

C0-00	Enabled condition of run command terminals when power up	Range: 0 - 1	Factory default: 0
-------	--	--------------	--------------------

This parameter is only for digital terminals with parameter value 1 - 4 (forward/reverse jog, and forward/reverse running), and also is only for initial running after power up.

0: Trigger edge detected + ON detected

When run command is controlled by terminals, the drive will start to run when it detects that the terminal jumps from OFF to ON and is kept ON after power up.

If run command terminal is in ON state before power up, the drive will not run after power up. Under this circumstance, only when the ON state is shifted to OFF and then ON again, and maintain ON, the drive will start running.

1: ON detected

When run command is controlled by terminals, the drive will start to run when detecting the command terminal at ON state after power up.

& ATTENTION:

When "1: ON detected" selected, the drive will start to run after power up as long as ON of run command terminal detected. Make sure of the safety of personnel and equipment before this setting.

C0-01	Function of terminal X1	Range: 0 - 99	Factory default: 0
C0-02	Function of terminal X2	Range: 0 - 99	Factory default: 0
C0-03	Function of terminal X3	Range: 0 - 99	Factory default: 0
C0-04	Function of terminal X4	Range: 0 - 99	Factory default: 0
C0-05	Function of terminal X5	Range: 0 - 99	Factory default: 0
C0-06	Function of terminal X6/DI	Range: 0 - 99	Factory default: 0
C0-07	Function of terminal EX (on IO expansion board)	Range: 0 - 99	Factory default: 0
C0-08	Function of terminal AI1 (Digital enabled)	Range: 0 - 99	Factory default: 0
C0-09	Function of terminal AI2 (Digital enabled)	Range: 0 - 99	Factory default: 0
C0-10	Function of terminal EAI (Digital enabled) (on IO expansion board)	Range: 0 - 99	Factory default: 0

Analogue input terminals AI1, AI2 and EAI can also be used as digital input terminals set by C0-08 - C0-10. When AI1, AI2 and EAI are used as analogue input, C0-08 - C0-10 shall be set to 0.

Parameter setting of digital input is as shown in Table 6-6:

Table 6-6 Digital input functions

Set value	Function	Set value	Function
0	No function	25	Motor 1/2 switchover
1	JOG forward	26	Reserved
2	JOG reverse	27	Run command switched to keypad control
3	Running forward (FWD)	28	Run command switched to terminal control
4	Running reverse (REV)	29	Run command switched to communication control
5	Three-wire control	30	Frequency command pattern shift
6	Running suspended	31	Master frequency command

Set value	Function	Set value	Function
			switched to digital setting b0-02
7	External stop	32	Auxiliary frequency command switched to digital setting b0-04
8	Emergency stop	33	PID adjustment direction
9	Stop command + DC brake	34	PID paused
10	DC brake stop	35	PID integration paused
11	Coast to stop	36	PID parameter switch
12	Terminal UP	37	Count input
13	Terminal DOWN	38	Count clear
14	UP/DOWN (including / key) adjustment clear	39	Length count
15	Multi-step frequency terminal 1	40	Length clear
16	Multi-step frequency terminal 2	41 - 62	Reserved
17	Multi-step frequency terminal 3	63	Simple PLC paused
18	Multi-step frequency terminal 4	64	Simple PLC disabled
19	Accel/Decel time determinant 1	65	Simple PLC stop memory clear
20	Accel/Decel time determinant 2	66	Start wobble frequency
21	Accel/Decel disabled(ramp stop not inclusive)	67	Clear wobble frequency status
22	External fault input	68	Running prohibited
23	Fault reset (RESET)	69	DC braking in running
24	Pulse input (valid only for X6/DI)	70 - 99	Reserved

0: No function

1: JOG forward

Perform jog forward through terminals. Jog frequency is set by b0-19, jog Accel time set by b2-10, and jog Decel time set by b2-11. Refer to C0-00 for enabled conditions on initial power up.

2: JOG reverse

Perform jog reverse through terminals. Jog frequency is set by b0-19, jog Accel time set by b2-10, and jog Decel time set by b2-11. Refer to C0-00 for enabled conditions on initial power up.

3: Forward (FWD)

Terminals control forward running of the drive. Refer to C0-00 for enabled conditions on initial power up.

4: Reverse (REV)

Terminals control reverse running of the drive. Refer to C0-00 for enabled conditions on initial power up.

5: Three-wire control

There are two-wire control and three-wire control about Forward (FWD) and reverse (REV). In case of three-wire control is enabled, "three-wire control" terminal is activated. For details, refer to C0-19 (FWD/REV terminal control mode).

6: Running suspended

When "running suspended" terminal is enabled during the running, the drive will block the output and perform zero-frequency running. Once "running suspended" terminal becomes disabled, the drive restores the running.

7: External stop

No matter which type of b1-00 is set to, the drive will stop by enabled "external stop" terminal, in the manner of stop mode.

8: Emergency stop

When "emergency shutdown" is enabled, the drive will stop in accordance with Decel time set by b2-09. Please set b2-09 to an appropriate value so as to minimize the Decel time for emergency stop.

9: Stop command + DC brake

The drive performs ramp-down stop when "stop command+ DC brake" terminal is enabled. It will perform DC brake when output frequency attains brake starting frequency. Brake starting frequency and brake current are set by b1-14 and b1-15. Brake time is determined by the maximum of b1-16 and the lasting time of this terminal.

10: DC brake stop

The drive performs "ramp to stop + DC brake" (same as b1-13 is set to 2) when "DC brake stop" is enabled, in the manner set by b1-14, b1-15 and b1-16.

11: Coast to stop

When "coast to stop" terminal is enabled, the drive will immediately cut off its output and the motor will coast to stop.

12: Terminal UP

13: Terminal DOWN

Terminals are used to increase and decrease the command frequency. The command frequency will be increased and decreased when "digital setting + terminal UP/DOWN adjustment" is enabled. The adjustment "step size" is set by C0-18. Refer to C0-17 for Terminal UP/DOWN frequency adjustment treatment.

14: UP/DOWN (including / key) adjustment clear

When frequency command is "digital setting + terminal UP/DOWN adjustment" or "digital setting + keypad \wedge / \vee adjustment", this enabled terminal will clear the adjusted value via terminals UP/DOWN and keys \wedge / \vee , to digital set value b0-02 or b0-04.

15: Multi-step frequency terminal 1

16: Multi-step frequency terminal 2

17: Multi-step frequency terminal 3

18: Multi-step frequency terminal 4

At most 16-step frequency can be attained via combination of multi-step frequency terminals 1 - 4, as shown in Table 6-7:

Table 6-7

Multi-step frequency terminal 4	Multi-step frequency terminal 3	Multi-step frequency terminal 2	Multi-step frequency terminal 1	Command frequency
OFF	OFF	OFF	OFF	Multi-step frequency 0 (F1-00)
OFF	OFF	OFF	ON	Multi-step frequency 1 (F1-01)
OFF	OFF	ON	OFF	Multi-step frequency 2 (F1-04)
OFF	OFF	ON	ON	Multi-step frequency 3 (F1-05)
OFF	ON	OFF	OFF	Multi-step frequency 4 (F1-06)
OFF	ON	OFF	ON	Multi-step frequency 5 (F1-07)
OFF	ON	ON	OFF	Multi-step frequency 6 (F1-08)
OFF	ON	ON	ON	Multi-step frequency 7 (F1-09)
ON	OFF	OFF	OFF	Multi-step frequency 8 (F1-10)
ON	OFF	OFF	ON	Multi-step frequency 9 (F1-11)
ON	OFF	ON	OFF	Multi-step frequency 10 (F1-12)
ON	OFF	ON	ON	Multi-step frequency 11 (F1-13)
ON	ON	OFF	OFF	Multi-step frequency 12 (F1-14)
ON	ON	OFF	ON	Multi-step frequency 13 (F1-15)
ON	ON	ON	OFF	Multi-step frequency 14 (F1-16)
ON	ON	ON	ON	Multi-step frequency 15 (F1-17)

19: Accel/Decel time determinant 1

20: Accel/Decel time determinant 2

Accel/Decel time determinant 1 - 2 can realize at most 4 Accel/Decel time settings through combination of different statuses as shown in Table 6-8. Accel/Decel time can be switched via different combinations during running.

Table 6-8

Accel/Decel time determinant 2	Accel/Decel time determinant 1	Accel/Decel time
OFF	OFF	Accel/Decel time 1 (b2-01, b2-02)
OFF	ON	Accel/Decel time 2 (b2-03, b2-04)
ON	OFF	Accel/Decel time 3 (b2-05, b2-06)
ON	ON	Accel/Decel time 4 (b2-07, b2-08)

& ATTENTION:

- ∅ The selection of Accel/Decel time 1 - 4 is not determined by digital input terminals when the drive is running under simple PLC. See parameter Group F2 for details.
- ∅ When broken-line Accel/Decel is enabled, Accel/Decel time is automatically switched to Accel/Decel time 1 and 2 according to switching frequency (b2-13 and b2-14). In this case, Accel/Decel time determinant terminals are disabled.

21: Accel/Decel disabled(ramp stop not inclusive)

When "Accel/Decel disabled" terminal is enabled, the drive maintains the present output frequency and no longer responds to the change of command frequency. But it will still perform ramp-down stop when receiving stop command. This terminal is disabled during normal ramp-down stop.

22: External fault input

This terminal is used to input the fault signal of external equipment, making the drive to perform fault monitoring and protection. When external fault signal is received, the drive shall display "PEr" and stop running.

23: Fault reset (RESET)

When the drive fault occurs, this enabled terminal will reset the fault. This function is the same with RESET key on keypad.

24: Pulse input (valid only for X6/DI)

This is valid only for digital input terminal X6/DI. This terminal receives pulse signal as frequency command. Refer to C2-24 - C2-27 for the relationship between pulse signal and command frequency.

When pulse input is selected as the frequency command, X6/DI terminal must be set to "pulse input" (C0-06 is set to 24).

25: Motor 1/2 switchover

The loaded motor can be selected via this terminal as shown in Table 6-9:

Table 6-9

A0-08	Motor 1/2 switchover terminal	Loaded motor
0	OFF	Motor 1
0	ON	Motor 2
1	OFF	Motor 2
1	ON	Motor 1

Set parameters of motor 1 in parameter groups d0 - d2, and set parameters of motor 2 in groups d3 - d5.

26: Reserved

27: Run command switched to keypad control

This terminal should be enabled by trigger edge. When this terminal status is switched from OFF to ON, run command will be switched to keypad control.

28: Run command switched to terminal control

This terminal should be enabled by trigger edge. When this terminal status is switched from OFF to ON, run command will be switched to terminal control.

29: Run command switched to communication control

This terminal should be enabled by trigger edge. When this terminal is switched from OFF to ON, run command will be switched to communication control.

30: Frequency command pattern shift

When b0-00 is set to 2, 3 and 4, switch during various frequency command patterns can be performed via "frequency command patterns shift" terminal.

When b0-00 is set to 2, this terminal shall shift between master frequency command and auxiliary frequency command.

When b0-00 is set to 3, this terminal shall shift between master frequency command, and master & auxiliary computation result.

When b0-00 is set to 4, this terminal shall shift between auxiliary frequency command, and master & auxiliary computation result.

31: Master frequency command switched to digital setting b0-02

When this terminal is disabled, b0-01 determines master frequency command. When it is enabled, master frequency command is forcibly switched to the value of b0-02.

& ATTENTION:

This terminal is disabled when the binding of run command and frequency command is set by b1-01.

32: Auxiliary frequency command switched to digital setting b0-04

When this terminal is enabled, b0-03 determines auxiliary frequency command. When it is enabled, auxiliary frequency command is forcibly switched to the value of b0-04.

33: PID adjustment direction

The combination of this terminal and value of F0-04 (PID positive and negative adjustment), can determine the positive or negative characteristics of PID adjustment.

Table 6-10

F0-04	PID adjustment direction terminal	Adjustment characteristic
0	OFF	Positive action
0	ON	Negative action
1	OFF	Negative action
1	ON	Positive action

34: PID paused

When this terminal is enabled, PID adjustment is paused, and the drive will maintain current output frequency. After this terminal becomes disabled, PID adjustment recovers.

35: PID integration paused

When this terminal is enabled, PID integrator stops its integration, and the current value is maintained. After this terminal becomes disabled, PID restores its integration.

36: PID parameter switch

When F0-14 (PID parameter switch) is set to "2: switched by terminal", this terminal could be used to realize the switching between two groups of PID parameters. When this terminal is enabled, PID parameters are Kp1 and Ti1, Td1 which are determined by F0-08 - F0-10. When this terminal is disabled, PID parameters are Kp2, Ti2 and Td2 which are determined by F0-11 - F0-13.

37: Count input

The maximum frequency at count pulse input terminal is 200Hz, and the count value can be memorized in case of power loss. With the setting of F3-12 (set count value) and F3-13 (designated count value), this terminal can control digital output "set count value attained" and "designated count value attained".

38: Count clear

Used with "count input" terminal, to clear pulse count value.

39: Length count

It is used for fixed-length control, and only takes effect on digital input terminal X6/DI. The length is calculated via pulse input. Please refer to specification of parameters F3-08 - F3-11 for details. When the length is attained, digital output terminal "length attained" shall output effective signal. The current length value will be memorized on power loss.

40: Length clear

Used with "length count" terminal, to clear the length calculated.

41 - 62: Reserved

63: Simple PLC paused

When simple PLC is running and this terminal is enabled, the current PLC status (running

time and step) will be memorized, and the drive will run at 0Hz. When this terminal is disabled, the drive restores its running from the memorized moment.

64: Simple PLC disabled

When simple PLC is running, and this terminal is enabled. The status of PLC will be cleared and the output frequency is 0Hz. When this terminal is disabled again, the drive resumes PLC running from step 0.

65: Simple PLC stop memory clear

Under simple PLC running, if this terminal is enabled in stop status, the memorized information of PLC running step, running time and running frequency will be all cleared. Refer to parameter Group F2 for more information.

66: Start wobble frequency

This terminal takes effect only when F3-00 is set to "1: wobble frequency function enabled" and F3-01 unit's place is set to "started through terminal".

When this terminal is disabled, the drive runs at preset wobble frequency set by F3-02. When this terminal is enabled, the drive would activate wobble-frequency running immediately. Refer to Group F3 for details of wobble frequency.

67: Clear wobble frequency status

When the drive is running at wobble frequency, if this terminal is enabled, the memorized wobble frequency status will be cleared, no matter which wobble frequency start method (automatic/ via terminal) is taken. When this terminal is disabled, wobble frequency would resume. Refer to Group F3 for information of wobble frequency.

68: Running prohibited

When this terminal is enabled, the drive will coast to stop if it's running, and will prohibit start running if it's in a standby state. This terminal mainly applies to the situation where safety interlocking is required. Only after this terminal becomes disabled, the drive can be restarted.

69: DC brake in running

When this terminal is enabled, the drive will immediately fall into DC brake. After the terminal becomes disabled, the drive will be restored to normal state and ramp up to the command frequency with the set ramp up time.

& ATTENTION:

When this terminal is enabled, output frequency does not need to decelerate to brake start frequency, but will directly inject DC whose value is set by b1-15.

70 - 99: Reserved

C0-11	Filtering time of digital input terminal	Range: 0.000s - 1.000s	Factory default: 0.010s
-------	--	------------------------	-------------------------

Set the filtering time of X1 - X6 (when X6 is used as ordinary low-speed terminal), EX, AI1, AI2 and EAI (when used as digital input terminal). Interference immunity of digital input terminals can be improved by appropriate filtering time. However, the response time of digital input terminal will become slower when filtering time is increased.

& ATTENTION:

This filtering time takes no effect on X6/DI when X6/DI terminal is used as DI high-speed input terminal, while the filtering time of DI is determined by parameter C2-28.

C0-12	Delay time of terminal X1	Range: 0.0s - 3600.0s	Factory default: 0.0s
C0-13	Delay time of terminal X2	Range: 0.0s - 3600.0s	Factory default: 0.0s

The delayed response time of digital input terminals X1 and X2 is set by these two parameters.

& ATTENTION:

Terminal delay time C0-12 and C0-13 can be set with filtering time C0-11 at the same time. The drive will respond after the signals via X1 and X2 go through filtering time, and then delay time. Terminals X3 - X6 and EX have no delay time function.

C0-14	Digital input terminal enabled status setting 1	Range: 0000 - 1111	Factory default: 0000
-------	---	--------------------	-----------------------

┌ Unit's place: X1

0: Positive logic; ON when current passes through

1: Negative logic; ON when no current passes through

┌ Decade: X2 (same as X1)

┌ Hundreds place: X3 (same as X1)

┌ Thousands place: X4 (same as X1)

C0-15	Digital input terminal enabled status setting 2	Range: 000 - 111	Factory default: 000
-------	---	------------------	----------------------

┌ Unit's place: X5

0: Positive logic; ON when current passes through

- 1: Negative logic; ON when no current passes through
- ⊔ Decade: X6 (same as X5)
- ⊔ Hundreds place: EX (on IO expansion board; same as X5)

C0-16	Digital input terminal enabled status setting 3	Range: 000 - 111	Factory default: 000
-------	---	------------------	----------------------

This parameter sets the enabled condition of AI1, AI2 and EAI as digital input terminal (need to be defined by C0-08 - C0-10).

- ⊔ Unit's place: AI1
- 0: Positive logic; < 5V, ON; > 5V, OFF
- 1: Negative logic; < 5V, OFF; > 5V, ON
- ⊔ Decade: AI2 (same as AI1)
- ⊔ Hundreds place: EAI (on IO expansion board; same as AI1)

C0-17	Terminal UP/DOWN frequency adjustment treatment	Range: 000 - 111	Factory default: 0000
-------	---	------------------	-----------------------

- ⊔ Unit's place: action when stop
- 0: Clear
Terminal UP/DOWN frequency adjustment value is cleared when the drive stops.
- 1: Holding
Terminal UP/DOWN frequency adjustment value is maintained when the drive stops.
- ⊔ Decade: action on power loss
- 0: Clear
Terminal UP/DOWN frequency adjustment value is cleared in case of power loss.
- 1: Holding
Terminal UP/DOWN frequency adjustment value is saved in case of power loss.
- ⊔ Hundreds place: integral function
- 0: No integral function
Adjustment step size is kept constant during terminal UP/DOWN adjustment, in compliance with C0-18.
- 1: Integral function enabled
When frequency is adjusted through terminal UP/DOWN, initial step size is set by C0-18. With the effective lasting time of the terminals, adjustment step size will increase gradually.

C0-18	Terminal UP/DOWN frequency change step size	Range: 0.00Hz/s - 100.00Hz/s	Factory default: 0.03Hz/s
-------	---	------------------------------	---------------------------

When frequency command is "digital setting + terminal UP/DOWN adjustment", this parameter is used to set the step size of frequency adjustment UP/DOWN. The step size is defined as frequency change per second, and the smallest step size is 0.01 Hz/s.

C0-19	FWD/REV terminal control mode	Range: 0 - 3	Factory default: 0
-------	-------------------------------	--------------	--------------------

There are four different methods when run command is determined by FED/REV terminal. This terminal control mode takes no effect on JOG.

0: Two-wire mode 1

FWD terminal inputs forward run command, while REV terminal inputs reverse run command.

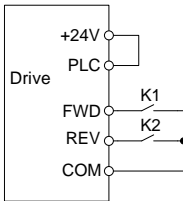

Fig. 6-17

Table 6-11

FWD	REV	Run command
OFF	OFF	Stop
OFF	ON	Reverse
ON	OFF	Forward
ON	ON	Stop

1: Two-wire mode 2

FWD terminal inputs run command, while REV terminal inputs running direction.

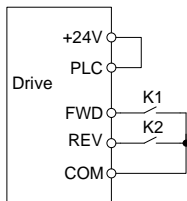

Fig. 6-18

Table 6-12

FWD	REV	Running command
OFF	OFF	Stop
OFF	ON	Reverse
ON	OFF	Forward
ON	ON	Stop

2: Three-wire mode 1

FWD terminal controls forward running of the drive, REV terminal controls reverse running, and digital input terminal "three-wire running" controls the stop. Input signals of all these three terminals take effect when trigger edge is detected.

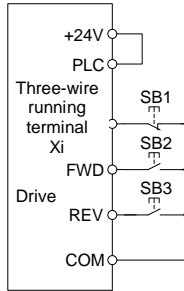

Fig. 6-19 Three-wire mode 1

SB1 is a stop button, by pressing which the drive will stop;

SB2 is a FORWARD button, by pressing which forward running will be activated;

SB3 is a REVERSE button, by pressing which reverse running will be activated.

Xi is a digital input terminal. In this case, it is necessary to define the function of corresponding terminal as "three-wire running" terminal.

3: Three-wire mode 2

FWD terminal controls the running, while running direction is determined by REV terminal. Digital input terminal "three-wire running" controls the stop.

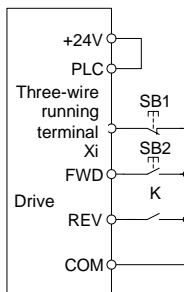

Fig. 6-20 Three-wire mode 2

SB1 is a stop button, by pressing which the drive will stop;

SB2 is a RUN button, by pressing which the drive will run. When switch K is open, running is forward, while when it is closed, running is reverse.

Xi is a digital input terminal. In this case, it is necessary to define the function of corresponding terminal as "three-wire running" terminal.

C0-20	Option of virtual input terminal	Range: 000 - 77F	Factory default: 000
-------	----------------------------------	------------------	----------------------

This parameter is a 10-bit binary numeral. The terminals that correspond respectively to bit9 (the highest bit of binary system) through bit0 (the lowest bit of binary system) are as follows:

Table 6-13

Hundreds place			Decade				Unit's place			
bit10	bit9	bit8	bit7	bit6	bit5	bit4	bit3	bit2	bit1	bit0
EAI	AI2	AI1	Reserve	EX	X6	X5	X4	X3	X2	X1

⊃ Unit's place: bit0 - bit3 : X1 - X4

0: Actual terminal takes effect

1: Virtual terminal takes effect

⊃ Decade: bit4 - bit6 : X5, X6, EX

0: Actual terminal takes effect

1: Virtual terminal takes effect

⊃ Hundreds place: bit8 - bit10 : AI1, AI2, EAI

0: Actual terminal takes effect

1: Virtual terminal takes effect

Virtual terminals simulate actual terminals via communication. Each bit represents one terminal. When selecting virtual terminal, corresponding bit should be set to 1 in C0-20.

Group C1 Digital Output

C1-00	Y1 output function	Range: 0 - 99	Factory default: 0
C1-01	Y2/DO output function (when used as Y2)	Range: 0 - 99	Factory default: 0
C1-02	Control panel relay output function	Range: 0 - 99	Factory default: 14
C1-03	Expansion board relay output function	Range: 0 - 99	Factory default: 15

Define the functions of digital output terminals Y1 & Y2, control board relay and expansion board relay. When used as high-speed pulse output, Y2/DO terminal's function are not set in C1-01 but in C3-02.

Output terminal function selections are as follows:

Table 6-14

Setting	Corresponding function	Setting	Corresponding function
0	No output	17	Drive thermal alarm
1	Drive undervoltage	18	Zero-current detection
2	Drive running preparation completed	19	X1
3	Drive is running	20	X2
4	Drive in 0Hz running (no output at stop)	21	Motor 1/2 indication
5	Drive in 0Hz running (output at stop)	22	Set count value attained
6	Running direction	23	Designated count value attained
7	Frequency attained	24	Length attained
8	Upper limit frequency attained	25	Consecutive running time attained
9	Lower limit frequency attained	26	Accumulative running time attained
10	Frequency higher than FDT 1	27	Contracting brake control
11	Frequency higher than FDT 2	28	Reserved
12	Reserved	29	Reserved
13	Torque limited	30	PLC step completed
14	Fault output	31	PLC cycle completed
15	Alarm output	32	Wobble frequency attains to upper or lower limit frequency
16	Drive (motor) overloaded alarm	33 - 99	Reserved

0: No output

Output terminal is disabled, and there is no output.

1: Drive undervoltage

When DC bus voltage is lower than the level of undervoltage, output ON signal and LED keypad displays "LoU".

2: Drive running preparation completed

The output of ON signal indicates that the drive is free of fault, the bus voltage is normal, and the running prohibition terminal is disabled. Under this circumstance, run command is

acceptable.

3: Drive is running

The output is ON when the drive is running, and output is OFF when drive stopped.

4: Drive in 0Hz running (no output at stop)

When be running at 0Hz, this corresponding terminal outputs ON signal. No ON signal will be output at stop.

5: Drive in 0Hz running (output at stop)

Outputs ON signal when is running at 0Hz and also outputs ON signal at stop.

6: Running direction

Outputs OFF signal under forward running and outputs ON signal under reverse running.

7: Frequency attained

When the deviation of output frequency from command frequency is less than the value of C1-14 (Detective width of frequency attained), outputs ON.

8: Upper limit frequency attained

When output frequency attains b0-09 (upper limit frequency), outputs ON.

9: Lower limit frequency attained

When output frequency attains b0-10 (lower limit frequency), outputs ON.

10: Frequency higher than FDT 1

Terminal outputs ON signal when output frequency exceeds C1-10 (FDT1 upper bound) and will not output OFF signal unless output frequency drops to below C1-11 (FDT1 lower bound).

11: Frequency higher than FDT 2

Terminal outputs ON when output frequency exceeds C1-12 (FDT2 upper bound) and will not output OFF unless output frequency drops to below C1-13 (FDT2 lower bound).

12: Reserved

13: Torque limited

This takes effect only in the mode of sensor-less vector control. If output torque attains the limit value of drive torque or brake torque, terminal outputs ON.

14: Fault output

When the drive is in fault, outputs ON.

15: Alarm output

When inverter gives an alarm, ON signal is output.

16: Drive (motor) overloaded alarm

In case drive output current exceeds E1-04 (overload alarm threshold) and its last time exceeds E1-05 (overload alarm activated time that exceeding threshold), outputs ON. Refer to parameters E1-03 - E1-05 for information with regard to drive (motor) overloaded alarm.

& ATTENTION:

In case of either drive is overloaded or motor is overloaded, also will output ON.

17: Drive thermal alarm

When drive internally detected temperature exceeds E1-13 (Drive thermal alarm threshold), ON signal will be output.

18: Zero-current detection

When drive output current is less than the value of C1-15 (effective proportion of zero current detected) and the lasting time attains the value of C1-16 (Zero current detected time), ON signal will be output.

19: X1

Output the status of X1.

20: X2

Output the status of X2.

21: Motor 1/2 indication

When motor 1 is selected, outputs OFF. When motor 2 is selected, outputs ON.

22: Set count value attained

Refer to the specification of parameter F3-12.

23: Designated count value attained

Refer to the specification of parameter F3-13.

24: Length attained

Refer to the specification of parameters F3-08 - F3-11.

25: Consecutive running time attained

When consecutive running time attains the value of E0-03, corresponding terminal outputs ON. Consecutive running time is cleared when stop.

26: Accumulative running time attained

When accumulative running time attains the value of E0-04, corresponding terminal outputs ON. Accumulative running time is maintained when stop.

27: Contracting brake control

Refer to the specification of parameters E0-05 - E0-11 for details.

28: Reserved

29: Reserved

30: PLC step completed

Upon the completion of current step of simple PLC running, ON signal with the width of 500ms will be output.

31: PLC cycle completed

Upon the completion of a cycle of simple PLC running, ON signal with a width of 500ms will be output.

32: Wobble frequency attains to upper or lower limit frequency

When drive output frequency attains upper limit frequency b0-09 or lower limit frequency b0-10 under wobble frequency running, ON signal will be output.

33 - 99: Reserved

C1-04	Y1 output delay time	Range: 0.0s - 3600.0s	Factory default: 0.0s
C1-05	Y2 output delay time	Range: 0.0s - 3600.0s	Factory default: 0.0s
C1-06	Control board relay output delay time	Range: 0.0s - 3600.0s	Factory default: 0.0s
C1-07	Expansion board relay output delay time	Range: 0.0s - 3600.0s	Factory default: 0.0s

These four parameters define the delay response time of digital output terminals Y1 & Y2, control board relay and expansion board relay.

& ATTENTION:

When Y2/DO terminal is used as high-speed pulse output (set by C3-02), delay time set by C1-05 is disabled.

C1-08	Enabled state of digital output	Range: 0000 - 1111	Factory default: 0000
-------	---------------------------------	--------------------	-----------------------

- u Unit's place: Y1
 - 0: Positive logic; ON when current passes through
 - 1: Negative logic; ON when no current passes through
 - u Decade: Y2 (same as Y1)
 - u Hundreds place: control board relay output
 - 0: Positive logic; ON when there is coil excitation
 - 1: Negative logic; ON when there is no coil excitation
 - u Thousands place: expansion board relay output (same as control board relay)
- Wiring diagram of digital output terminal is shown as Fig. 6-21:

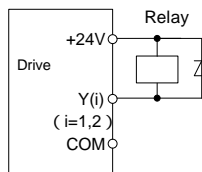

Fig. 6-21

C1-09	Detected object of frequency doubling technology(FDT)	Range: 00 - 11	Factory default: 00
-------	---	----------------	---------------------

- u Unit's place: FDT1 detective object
 - 0: Set value of speed (frequency after Accel/Decel)
- FDT1 output frequency is the command frequency after Accel/Decel.

1: Detected speed value

FDT1 output frequency is actually detected or identified frequency. If the drive is under V/f pattern, it should be output frequency.

└ Decade: FDT2 detective object

0: Set value of speed (frequency after Accel/Decel)

FDT2 output frequency is the command frequency after Accel/Decel.

1: Detected speed value

FDT2 output frequency is actually detected or identified frequency. If the drive is under V/f pattern, it should be output frequency.

C1-10	FDT1 upper bound	Range: 0.00Hz - maximum FREQ	Factory default: 50.00Hz
C1-11	FDT1 lower bound	Range: 0.00Hz - maximum FREQ	Factory default: 49.00Hz
C1-12	FDT2 upper bound	Range: 0.00Hz - maximum FREQ	Factory default: 25.00Hz
C1-13	FDT2 lower bound	Range: 0.00Hz - maximum FREQ	Factory default: 24.00Hz

These parameters should be set with digital output terminals "FDT1" and "FDT2".

Take FDT1 for example, the drive outputs ON signal when output frequency exceeds upper bound of FDT1 and will not output OFF signal unless output frequency drops to below lower bound of FDT1. Please set C1-10 to be larger to some certain extent than C1-11, avoiding status change frequently. See Fig. 6-22:

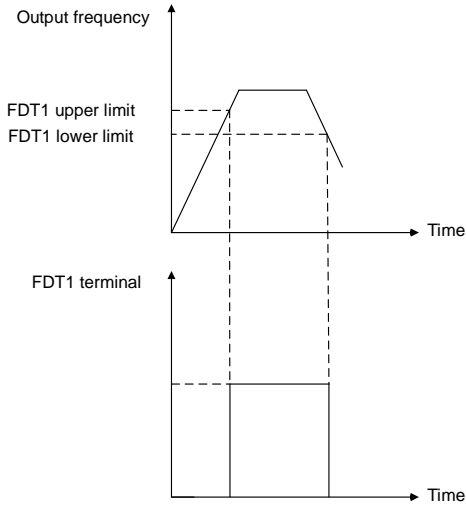

Fig. 6-22

C1-14	Detection width of frequency attained	Range: 0.00Hz - maximum FREQ	Factory default: 2.50Hz
-------	---------------------------------------	---------------------------------	----------------------------

This parameter should be set with digital output terminal "frequency attained". When the difference between output frequency and command frequency is less than this value, terminal "frequency attained" aoutputs ON. See Fig. 6-23:

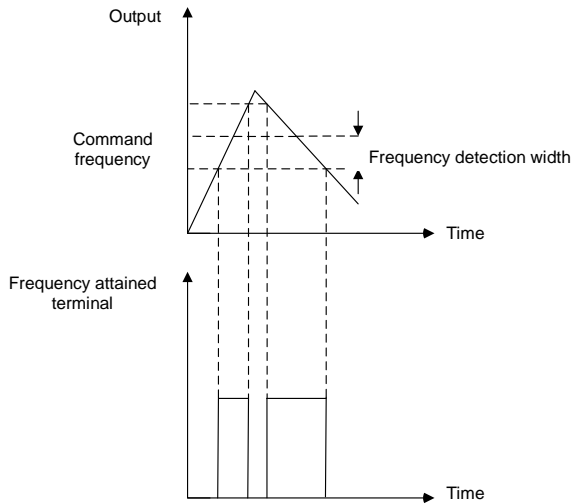

Fig. 6-23

C1-15	Zero current detection level	Range: 0.0% - 50.0%	Factory default: 5.0%
C1-16	Zero current detection time	Range: 0.01s - 50.00s	Factory default: 0.50s

The two parameters should be set with digital output terminal "zero current detection". When the drive output current is less than C1-15 and its lasting time attains the value of C1-16, terminal "zero current detection" outputs ON signal. See Fig. 6-24:

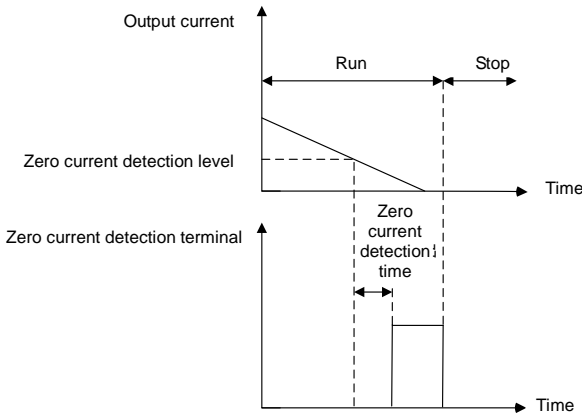

Fig. 6-24

Group C2 Analogue and Pulse Input

C2-00	Analogue input curve	Range: 000 - 222	Factory default: 000
-------	----------------------	------------------	----------------------

Curves of analogue input AI1, AI2 and EAI are selected by this parameter.

- Unit's place: AI1 input curve
 - 0: Curve 1 (2 points)
Defined by C2-01 - C2-04.
 - 1: Curve 2 (4 points)
Defined by C2-05 - C2-12.
 - 2: curve 3 (4 points)
Defined by C2-13 - C2-20.
- Decade: AI2 input curve
Same as specification of AI1.
- Hundreds place: EAI input curve
Same as specification of AI1.

C2-01	Maximum input of curve 1	Range: minimum input of curve 1 - 110.0%	Factory default: 100.0%
C2-02	Set value corresponding to maximum input of curve 1	Range: -100.0% to 100.0%	Factory default: 100.0%
C2-03	Minimum input of curve 1	Range: -110.0% to maximum input of curve 1	Factory default: 0.0%
C2-04	Set value corresponding to minimum input of curve 1	Range: -100.0% to 100.0%	Factory default: 0.0%

Curve 1 (2 points) is defined by above-noted 4 parameters.

Input values C2-01 and C2-03:

For EAI on expansion board and AI1 you can select 0 - 10V voltage input or 0 - 20mA current input with jumper.

If 0 - 10V is selected: 0V corresponds to 0%, while 10V corresponds to 100%.

If 0 - 20mA is selected: 0mA corresponds to 0%, while 20mA corresponds to 100%.

For 4 - 20mA or 2 - 10V input, set C2-03 to 20% to represent 4 mA as minimum input for curve 1.

AI2 only supports -10V to 10V input; for AI2, -10V corresponds to -100%, while 10V corresponds to 100%.

Corresponding set values C2-02 and C2-04:

When the corresponding set value is frequency: 100% is the maximum frequency, while -100% is the maximum negative frequency.

When the corresponding set value is current: 100% means 2 times the rated current of drive while "less than or equal to 0%" corresponds to zero current.

When corresponding set value is torque: 100% means 2 times the rated torque, while -100% means negative "2 times the rated torque".

When the corresponding set value is output voltage (e.g. the voltage setting in case of V/f separated pattern): 100% corresponds to rated voltage of motor. "Less than or equal to 0%" corresponds to 0V voltage.

See also example in chapter 4.2.1.3.

Curve diagram is shown as below:

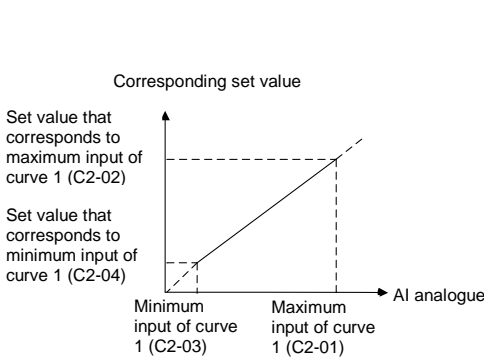

Fig. 6-25

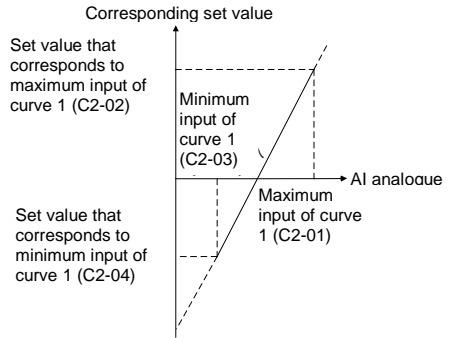

Fig. 6-26

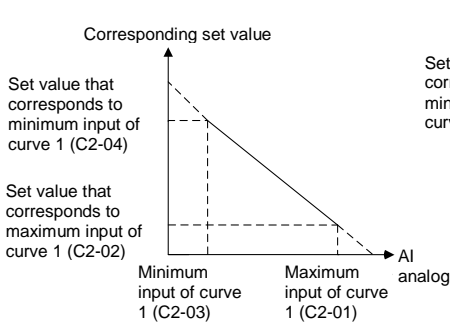

Fig. 6-27

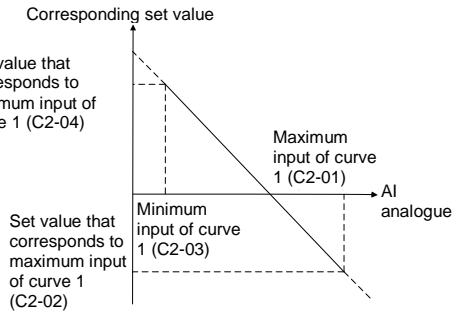

Fig. 6-28

C2-05	Maximum input of curve 2	Range: input of inflection point A of curve 2 - 110.0%	Factory default: 100.0%
C2-06	Set value corresponding to maximum input of curve 2	Range: -100.0% to 100.0%	Factory default: 100.0%
C2-07	Input of inflection point A of curve 2	Input of inflection point B of curve 2 - maximum input of curve 2	Factory default: 0.0%
C2-08	Set value corresponding to input of inflection point A of curve 2	Range: -100.0% to 100.0%	Factory default: 0.0%
C2-09	Input of inflection point B of curve 2	Range: minimum input of curve 2 - Input of inflection point A of curve 2	Factory default: 0.0%
C2-10	Set value corresponding to input of inflection point B of curve 2	Range: -100.0% to 100.0%	Factory default: 0.0%
C2-11	Minimum input of curve 2	Range: -110.0% to input of inflection point B of curve 2	Factory default: 0.0%
C2-12	Set value corresponding to minimum input of curve 2	Range: -100.0% to 100.0%	Factory default: 0.0%

Description of input value of curve 2: Voltage input:

- 1) With regard to AI1 and the EAI on expansion board, 0% corresponds to 0V or 0mA, while 100% corresponds to 10V or 20mA.

For 4 – 20mA or 2 – 10V input, set C2-11 to 20% to represent 4 mA or 2V as minimum input for curve 2.

- 2) Regarding to AI2, -100% corresponds to -10V, while 100% corresponds to 10V.

Curve 2 is defined by C2-05 - C2-12. The input of curve 2 and the definition of corresponding set value is the same as AI1. The difference is that curve 1 is a straight line while curve 2 is a broken line with two inflection points. Diagram of curve 2 is shown as below:

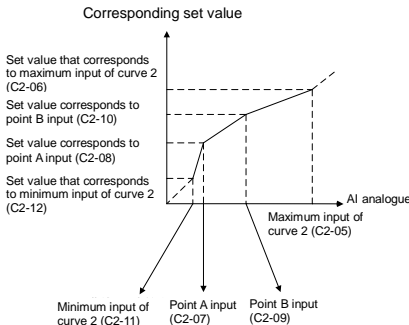

Fig. 6-29

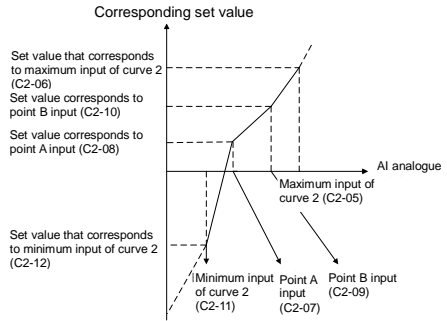

Fig. 6-30

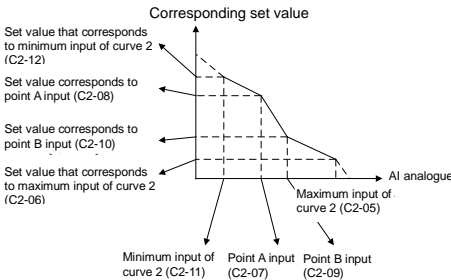

Fig. 6-31

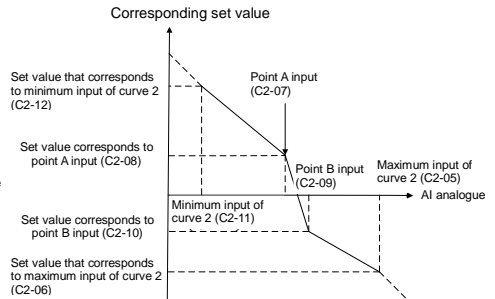

Fig. 6-32

C2-13	Maximum input of curve 3	Range: input of inflection point A of curve 3 - 110.0%	Factory default: 100.0%
C2-14	Set value corresponding to maximum input of curve 3	Range: -100.0% to 100.0%	Factory default: 100.0%
C2-15	Input of inflection point A of curve 3	Range: input of inflection point B of curve 3 - maximum input of curve 3	Factory default: 0.0%
C2-16	Set value corresponding to input of inflection point A of curve 3	Range: -100.0% to 100.0%	Factory default: 0.0%
C2-17	Input of inflection point B of curve 3	Range: minimum input of curve 3 - input of inflection point A of curve 3	Factory default: 0.0%
C2-18	Set value corresponding to input of inflection point B of curve 3	Range: -100.0% to 100.0%	Factory default: 0.0%

C2-19	Minimum input of curve 3	Range: -110.0% to input of inflection point B of curve 3	Factory default: 0.0%
C2-20	Set value corresponding to minimum input of curve 3	Range: -100.0% to 100.0%	Factory default: 0.0%

Curve 3 is defined by C2-13 - C2-20. The usage of curve 3 is the same as that of curve 2.

Note that for 4 – 20mA or 2 – 10V input, set C2-19 to 20% to represent 4 mA or 2V as minimum input for curve 3.

C2-21	AI1 terminal filtering time	Range: 0.000s - 10.000s	Factory default: 0.01s
C2-22	AI2 terminal filtering time	Range: 0.000s - 10.000s	Factory default: 0.01s
C2-23	EAI terminal filtering time	Range: 0.000s - 10.000s	Factory default: 0.01s

C2-21 - C2-23 define the filtering time of analogue input terminals AI1, AI2 and EAI. Long filtering time results in strong immunity from interference but slow response, while short filtering time brings rapid response but weak immunity from interference.

C2-24	DI maximum input	Range: C2-26 to 50.0kHz	Factory default: 50.0kHz
C2-25	Set value corresponding to DI maximum input	Range: -100.0% to 100.0%	Factory default: 100.0%
C2-26	DI minimum input	Range: 0.0kHz - C2-24	Factory default: 0.0kHz
C2-27	Set value corresponding to DI minimum input	Range: -100.0% to 100.0%	Factory default: 0.0%

When digital input terminal X6/DI receives pulse signal as frequency command, the relation between input pulse signal and command frequency is defined by curves set by C2-24 - C2-27.

C2-24 and C2-26 represent the range of DI input pulse frequency.

C2-25 and C2-27 are the set values of frequency that corresponds to DI input pulse frequency: 100% corresponds to positive maximum frequency while -100% corresponds to negative maximum frequency.

& ATTENTION:

When pulse input is selected as the frequency command, X6/DI terminal shall be set to "pulse input" function (C0-06 is set to 24).

C2-28	DI filtering time	Range: 0.000s - 1.000s	Factory default: 0.001s
-------	-------------------	------------------------	-------------------------

Define the filtering time of terminal X6/DI.

If AI (AI1, EAI1, EAI2 on extension boards) lower than C2-03, C2-11, C2-19 or bigger than C2-01, C2-05, C2-13 there will be an alarm " analogue input error". Error code: AIP.

C2-29	Interrupt detection time	Range: 0.00s - 100.00s	Factory default: 0.50s
-------	--------------------------	------------------------	---------------------------

When this parameter value is set to 0.00s it means no interrupt line detection (means no alarm even out of MIN-MAX)..

Group C3 Analogue and Pulse Output

C3-00	AO1 output function	Range: 0 - 99	Factory default: 2
C3-01	EAO output function (on IO expansion board)	Range: 0 - 99	Factory default: 1
C3-02	Y2/DO output function (when used as DO)	Range: 0 - 99	Factory default: 2

AO1 and EAO are analogue output terminals. When used as high-speed pulse output DO, Y2/DO terminal's functions are set in C3-02.

Voltage output or current output of AO1 and EAO can be selected through toggle switch. When S3 is switched to the position as shown in Fig. 6-33, AO1 output 0 - 10V. EAO analogue output terminal is located at expansion board.



Fig. 6-33

Output range of DO pulse frequency is 0 - C3-09 (maximum output pulse frequency).

The ranges of corresponding digital output of AO1, EAO and DO are as shown in the table 6-15.

Table 6-15

Parameter value	Function	Range
0	No output	No output
1	Command frequency	0 - maximum power
2	Output frequency	0 - maximum frequency
3	Output current	0 - 2 times the rated current of inverter

Parameter value	Function	Range
4	Output torque	0 - 2 times the rated torque
5	Output voltage	0 - 2 times the rated voltage of motor
6	Output power	0 - 2 times the rated power
7	Bus voltage	0 - 1000V
8	Reserved	Reserve
9	Torque current	0 - 2 times the rated current of motor
10	Magnetic flux current	0 - 2 times the rated current of motor
11	AI1	0 - 10V/0 - 20mA
12	AI2	-10V to 10V
13	EAI	0 - 10V/0 - 20mA
14	Reserved	Reserve
15	DI	0 - 50kHz
16	Communication input percentage	0 - 65535
17	Output frequency before compensation	0 - maximum frequency
18 - 99	Reserved	

C3-03	AO1 offset	Range: -100.0% to 100.0%	Factory default: 0.0%
C3-04	AO1 gain	Range: -2.000 to 2.000	Factory default: 1.000

When users need to change AO1 measuring range or correct the error of meter, it can be realized by setting of C3-03 and C3-04. When using factory default set: 0 - 10V (or 0 - 20mA) of AO1 corresponds to "0 - maximum". See table 6-15 for details. By expressing standard output of AO1 as x, the adjusted AO1 output as y, the gain as k, and the offset as b (100% of offset corresponds to 10V or 20mA), there is the equation: $y=kx+b$

Example:

Set C3-00 to 2: output frequency. Standard AO1 output: AO1 outputs 0V when output frequency is 0, and outputs 10V when output frequency is maximum frequency. If AO1 is requested to output 2V when output frequency is 0Hz, and to output 8V when output frequency is the maximum frequency.

There is: $2=k \times 0 + b$; $8=k \times 10 + b$. Through these two equations, we obtain: $k = 0.6$, $b = 2V$, i.e. C3-03 is set to 20.0% while C3-04 is set to 0.600.

Additional examples are shown as below:

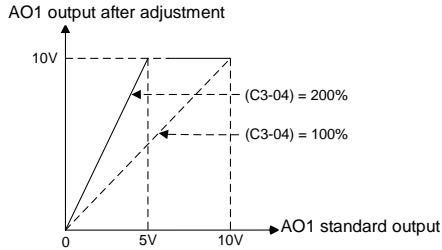

Fig. 6-34 Diagram of influence of AO1 gain on output

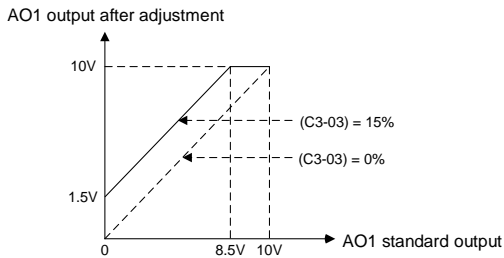

Fig. 6-35 Diagram of influence of AO1 offset on output

C3-05	AO1 filtering time	Range: 0.0s - 10.0s	Factory default: 0.0s
-------	--------------------	---------------------	--------------------------

Define output filtering time of AO1 terminal.

C3-06	EAO offset	Range: -100.0% to 100.0%	Factory default: 0.0%
C3-07	EAO gain	Range: -2.000 to 2.000	Factory default: 1.000
C3-08	EAO filtering time	Range: 0.0s to 10.0s	Factory default: 0.0s

Adjustment method of EAO output curve is the same as AO1.

C3-09	DO maximum output pulse frequency	Range: 0.1kHz to 50.0kHz	Factory default: 50.0kHz
-------	-----------------------------------	--------------------------	-----------------------------

This parameter sets the maximum output frequency when Y2/DO terminal is selected as high-speed pulse output.

C3-10	DO output center point	Range: 0 - 2	Factory default: 0
-------	------------------------	--------------	--------------------

There are three different center point modes when Y2/DO terminal is selected as high-speed pulse output.

0: No center point.

DO pulse frequency output range 0 - (C3-09) corresponds to "0 - maximum", as shown in Fig. 6-36:

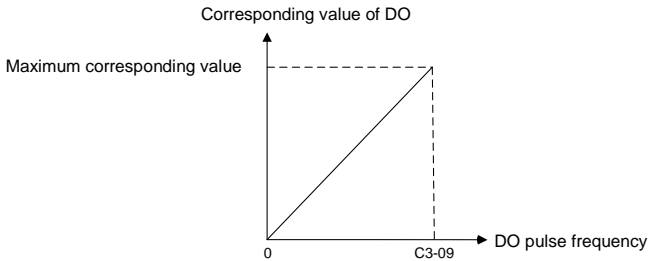

Fig. 6-36

1: Center point is $(C3-09)/2$, and the corresponding parameter value is positive when frequency is higher than center point. The value that corresponds to DO pulse frequency at center point is 0. DO pulse frequency C3-09 corresponds to the positive maximum value, while DO pulse frequency 0Hz corresponds to the negative maximum value. See Fig. 6-37:

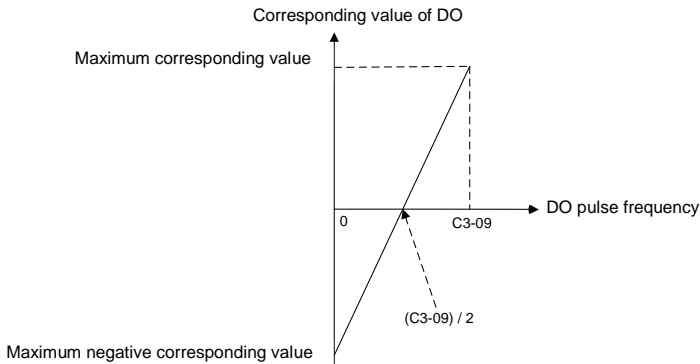

Fig. 6-37

2: Center point is (C3-09)/2, and the corresponding parameter value is positive when frequency is lower than center point. The value that corresponds to DO pulse frequency at center point is 0. When set to 0, DO pulse corresponds to the positive maximum value, while when set to C3-09, DO pulse frequency corresponds to the negative maximum value. See Fig. 6-38:

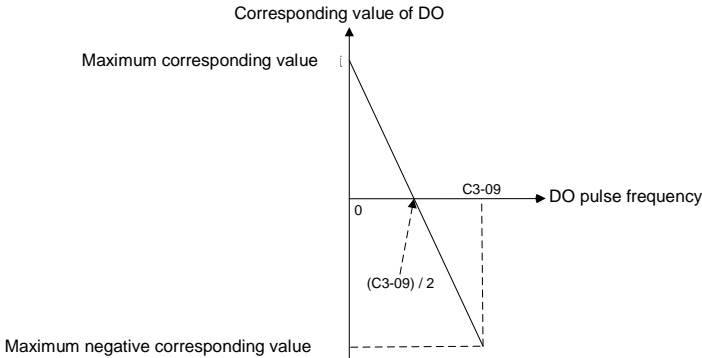

Fig. 6-38

C3-11	DO output filtering time	Range: 0.00s - 10.00s	Factory default: 0.01s
-------	--------------------------	-----------------------	------------------------

Set the filtering time of DO high-speed pulse output. Filtering can change the change rate of output pulse frequency. The longer the filtering time is, the lower the change rate of output pulse frequency would be.

Group C4 Automatic Correction of Analogue Input

Parameter Group C4 is used to perform automatic correction of analogue input channels, obtaining the gain and offset of corresponding channel automatically. They can automatically modify the measuring range of corresponding channel or correct meter error.

C4-00	Analogue corrected channel	Range: 0 - 3	Factory default: 0
-------	----------------------------	--------------	--------------------

0: No correction

No correction to any channels.

1: Correct AI1

Automatically correct analogue AI1 channel.

2: Correct AI2

Automatically correct analogue AI2 channel.

3: Correct EAI

Automatically correct analogue EAI channel.

C4-01	Sampling value of calibration point 1 of AI1	Range: 0.00V - 10.00V	Factory default: 1.00V
C4-02	Input value of calibration point 1 of AI1	Range: 0.00V - 10.00V	Factory default: 1.00V
C4-03	Sampling value of calibration point 2 of AI1	Range: 0.00V - 10.00V	Factory default: 9.00V
C4-04	Input value of calibration point 2 of AI1	Range: 0.00V - 10.00V	Factory default: 9.00V
C4-05	Sampling value of calibration point 1 of AI2	Range: -10.00V to 10.00V	Factory default: 1.00V
C4-06	Input value of calibration point 1 of AI2	Range: -10.00V to 10.00V	Factory default: 1.00V
C4-07	Sampling value of calibration point 2 of AI2	Range: -10.00V to 10.00V	Factory default: 9.00V
C4-08	Input value of calibration point 2 of AI2	Range: -10.00V to 10.00V	Factory default: 9.00V
C4-09	Sampling value of calibration point 1 of EAI	Range: 0.00V - 10.00V	Factory default: 1.00V
C4-10	Input value of calibration point 1 of EAI	Range: 0.00V - 10.00V	Factory default: 1.00V
C4-11	Sampling value of calibration point 2 of EAI	Range: 0.00V - 10.00V	Factory default: 9.00V
C4-12	Input value of calibration point 2 of EAI	Range: 0.00V - 10.00V	Factory default: 9.00V

Take AI2 for example, automatic correction is as follows

- 1) Set C4-00 to 2 in stop status and press ENT key to confirm. In this way, AI2 is selected as correction channel.
- 2) Input a relatively low analogue voltage (e.g. about 1V) via AI2 terminal, and input the theoretical value of this analogue voltage by C4-06 after the stabilization of this voltage input, and then press ENT key to confirm.
- 3) Input a relatively high analogue voltage (e.g. about 9V) via AI2 terminal, and input the theoretical value of this analogue voltage by C4-08 after the stabilization of this voltage input, and then press ENT key to confirm.
- 4) Upon the successful correction, C4-00 parameter will be restored to zero.

& ATTENTION:

- ∅ Set the theoretical value or actual value of analogue voltage in C4-06 and C4-08. This value can be either the set value of analogue output of peripheral equipment, or the actual voltage value of analogue input measured by a multimeter or other instruments.
- ∅ C4-05 and C4-07 are the sampling values of analogue input voltage. These values is for reference only. Do not write the value of C4-05 directly into C4-06, or write the value of C4-07 directly into C4-08.

Group d Motor and Control Parameters**Group d0 Parameters of Motor 1**

When motor 1 is selected as current load motor, please set motor parameters in Group d0.

d0-00	Type of motor 1	Range: 0 - 1	Factory default: 0
-------	-----------------	--------------	--------------------

0: Ordinary motor

1: Variable frequency motor

The major difference between ordinary motor and variable frequency motor lies in the handling of motor overload protection. Under low speed running, ordinary motor has poor heat dissipation, so motor overload protection shall be derated at low speed. Since fan-based heat dissipation of variable frequency motor is not affected by motor speed, low-speed overload protection is not necessarily derated. Therefore, please set d0-00 to 0 when driving ordinary asynchronous motor so as to protect the motor reliably.

d0-01	Power rating of motor 1	Range: 0.4kW - 6553.5kW	Factory default: model defined
d0-02	Rated voltage of motor 1	Range: 0V - 480V	Factory default: 380V
d0-03	Rated current of motor 1	Range: 0.0A - 6553.5A	Factory default: model defined
d0-04	Rated frequency of motor 1	Range: 0.00Hz - 600.00Hz	Factory default: 50.00Hz
d0-05	Number of poles of motor 1	Range: 1 - 80	Factory default: 4
d0-06	Rated speed of motor 1	Range: 0 - 65535 r/min	Factory default: model defined

Above-noted motor parameters must be correctly set according to motor nameplate. Please select the motor that suits the power class of the drive, or the control performance of the drive will drop dramatically.

d0-07	Stator resistance R1 of motor 1	Range: 0.001Ω - 65.535Ω	Factory default: model defined
d0-08	Leakage inductance L1 of motor 1	Range: 0.1mH - 6553.5mH	Factory default: model defined
d0-09	Rotor resistance R2 of motor 1	Range: 0.001Ω - 65.535Ω	Factory default: model defined
d0-10	Mutual inductance L2 of motor 1	Range: 0.1mH - 6553.5mH	Factory default: model defined
d0-11	No-load current of motor 1	Range: 0.0A - 6553.5A	Factory default: model defined
d0-12	Flux weakening coeff 1 of motor 1	Range: 0.0000 - 1.0000	Factory default: model defined
d0-13	Flux weakening coeff 2 of motor 1	Range: 0.0000 - 1.0000	Factory default: model defined
d0-14	Flux weakening coeff 3 of motor 1	Range: 0.0000 - 1.0000	Factory default: model defined

The drive needs above-noted parameters to control its matching motor. If the parameters of motor 1 is known, just write the actual value into d0-07 - d0-14 correspondingly.

After the identification of parameters of motor 1, above-noted parameters are automatically updated and saved. Parameters d0-07 - d0-09 are obtained through static identification, and parameters d0-07 - d0-14 are obtained through rotation identification. If above-noted parameters are unknown and it is not allowed to perform motor parameter identification, please input the parameters manually by referring to parameters of like motors.

If motor power rating d0-01 is changed, d0-02 - d0-14 will be automatically restored to default setting of the standard motor.

d0-22	Parameter identification of motor 1	Range: 0 - 2	Factory default: 0
-------	-------------------------------------	--------------	--------------------

Parameters for controlling the motor performance are automatically obtained through parameter identification, and the result will be automatically saved upon the completion of identification.

Be sure to correctly input motor 1 parameters d0-01 - d0-06 before parameter identification.

0: No action

1: Static identification

Static identification applies to the cases where rotating identification cannot be favorably performed due to the fact that it is impossible to disengage the motor from its load. After d0-22 is set to 1 and confirmed, press the key RUN to start static identification. d0-22 will be restored to 0 upon the successful completion of identification. In this way, parameters d0-07 -

d0-09 are obtained.

2: Rotating identification

To perform rotation identification, it is essential to disengage the motor from its load. Identification is prohibited when motor is loaded. After d0-22 is set to 2 and confirmed, press RUN to perform static identification, upon the completion of which, the motor would accelerate to a fixed frequency in the set ramp-up time, maintaining a period of time, and then stop by ramp down according to the set ramp down time. In this way, the identification comes to an end, and d0-22 will be restored to 0. Parameters d0-07 - d0-14 have be obtained after the successful completion of rotating identification. To perform rotating identification, please set appropriate ramp-up and ramp-down time (i.e. Accel/Decel time. If overcurrent or overvoltage fault occurs during identification, please prolong Accel/Decel time accordingly.

& ATTENTION:

- Ø Please make sure the motor is in a stationary state before the identification, or parameter identification cannot be performed normally.
- Ø Keypad displays "TUNE" and RUN indicator light is on during identification. RUN indicator light is off upon the completion of parameter identification.
- Ø Once parameter identification fails, the fault code "tUN" shall be displayed.

d0-23	Overload protection mode of motor 1	Range: 0 - 2	Factory default: 1
-------	-------------------------------------	--------------	--------------------

Determine the overload protection mode of motor 1.

0: No protection

Once 0 is selected, it would be impossible to perform motor overload protection. Please take care.

1: Judged from motor current

Provide overload protection judged from output current and its lasting time. Overload protection detection time is set by d0-24.

2: Judged from temperature transducer

Input motor temperature sensor signal through analogue input channel set by d0-25. The signal voltage is compared with the protection threshold set by d0-26. If it is higher than protection threshold, motor overload fault "oL2" could be displayed.

d0-24	Overload protection detection time of motor 1	Range: 0.1min - 15.0min	Factory default: 5.0min
-------	---	-------------------------	-------------------------

When d0-23 is set to "1: judged from motor current", overload protection time is determined by this parameter on the basis of the running current being 150% of motor rated current. An alarm of motor overload fault "oL2" shall be displayed once the lasting time exceeds this parameter value. Protection time when the running current is other value is automatically calculated according to inverse time lag characteristic curve. See Fig. 6-39.

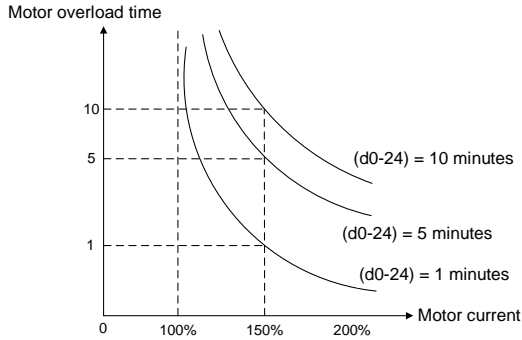

Fig. 6-39 Motor protection curve for ordinary motor running at 50Hz

Overload protection is performed for variable frequency motor according to the curve as shown in Fig. 6-39 at either high or low rotation speed. Due to the fact that fan-based heat dissipation of ordinary motors become poor at low speed, the protection is derated at low speed.

Example: when d0-24 is set to 10.0 minutes, and the motor is running at 10Hz input, motor overload fault "oL2" shall be displayed when the running current is 150% of the motor rated current with lasting time 4 minutes.

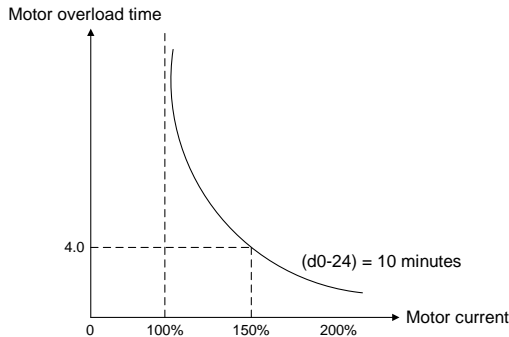

Fig. 6-40 Overload protection curve for ordinary motor running at 10Hz

d0-25	Input channel of temperature transducer signal of motor 1	Range: 0 - 2	Factory default: 1
-------	---	--------------	--------------------

0: AI1

1: AI2

2: EAI

When d0-23 is set to "2: judged from temperature transducer ", the analogue signal input channel of temperature sensor of motor 1 is set by this parameter. The drive compares the signal input value via this analogue channel with the thermal protection threshold set by d0-26. If it is bigger than the threshold, the drive will immediately give an alarm of motor overload "oL2". Protection through temperature sensor has no characteristic of inverse time lag curve.

d0-26	Thermal protection threshold of temperature transducer of motor 1	Range: 0.00V - 10.00V	Factory default: 10.00V
-------	---	-----------------------	-------------------------

This parameter is set with d0-25, setting the overload protection point of motor 1. When the input analogue signal through the channel selected by d0-25 is bigger than this threshold, the drive will immediately give an alarm of motor overload "oL2".

Group d1 V/f Control Parameters of Motor 1

Set control parameters in Group d1 when motor 1 is selected as current load motor on which V/f control is performed.

d1-00	V/f curve setting	Range: 0 - 8	Factory default: 0
-------	-------------------	--------------	--------------------

Set the relation between output voltage and output frequency of the drive when motor 1 is under V/f control.

0: Linear V/f

Applies to general constant-torque load. When drive output frequency is 0, output voltage will be 0, while when output frequency is rated frequency of motor, the output voltage would be rated voltage of motor.

1: Broken line V/f (determined by d1-01 - d1-08)

Applies to spin drier, centrifuge, industrial washing machine and other special loads. When drive output frequency is 0, output voltage will be 0, while when output frequency is rated frequency of motor, the output voltage would be rated voltage of motor. What is different is this pattern can set 4 inflection points by d1-01 - d1-08. See Fig. 6-41.

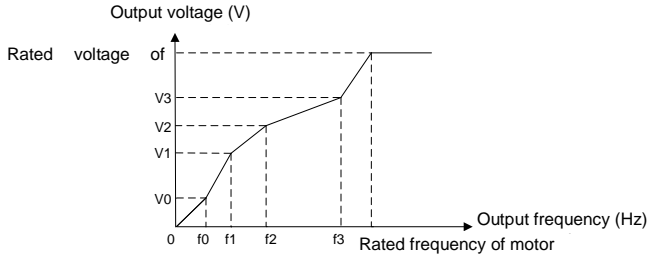

Fig. 6-41 User-defined various segments V/f curve

V0, V1, V2, V3 and f0, f1, f2 and f3 in the figure are voltage value and frequency value set by parameters d1-01 - d1-08.

- 2: 1.2nd power
- 3: 1.4th power
- 4: 1.6th power
- 5: 1.8th power
- 6: 2.0th power

Parameter values 2 - 6 apply to torque-dropped loads such as fans and water pumps. See Fig. 6-42.

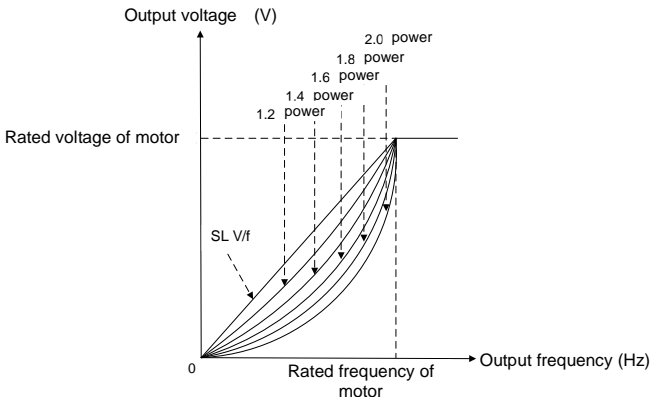

Fig. 6-42 1.2 - 2.0 power V/f curve

7: V/f separated pattern 1

Output frequency and output voltage can be set separately. Frequency is set by the method as stated in Group b0. Output voltage is set by d1-18. See d1-18 for details. This mode

applies to variable-frequency power supply or torque motor control etc.

8: V/f separated pattern 2

Determine a certain voltage by linear V/f mode, and then multiply this voltage by the proportion set by d1-18 to obtain drive output voltage. See d1-18 for details.

d1-01	V/f frequency value f3	Range: 0.00Hz - rated frequency of motor	Factory default: 50.00Hz
d1-02	V/f voltage value V3	Range: 0.0% - 100.0%	Factory default: 100.0%
d1-03	V/f frequency value f2	Range: d1-05 - d1-01	Factory default: 0.00Hz
d1-04	V/f voltage value V2	Range: 0.0% - 100.0%	Factory default: 0.0%
d1-05	V/f frequency value f1	Range: d1-07 - d1-03	Factory default: 0.00Hz
d1-06	V/f voltage value V1	Range: 0.0% - 100.0%	Factory default: 0.0%
d1-07	V/f frequency value f0	Range: 0.00Hz - d1-05	Factory default: 0.00Hz
d1-08	V/f voltage value V0	Range: 0.0% - 100.0%	Factory default: 0.0%

d1-01 - d1-08 is used for broken line V/f mode. Voltage value 100% corresponds to rated voltage of motor. Please rationally set the values of frequency and voltage at knees on the basis of characteristics of motor and load. Improper setting may rise output current even burn the motor.

d1-09	Torque boost	Range: 0.0% - 30.0%	Factory default: 0.0%
-------	--------------	---------------------	-----------------------

Under V/f pattern, output voltage at low frequency can be compensated by this parameter, improving the torque output. 0.0% corresponds to automatic torque boost, and drive output voltage is automatically compensated via detection of load current. Automatic torque boost is valid only for linear V/f pattern.

100% of torque boost corresponds to rated voltage of motor. A non-zero value means the output voltage rises on the basis of V/f curve and this takes effect at parameter values 0 - 6 of d1-00. It is suggested this parameter value be gradually increased from zero until the starting requirement is met. Boost value is not suggested to be set to a relatively big one, as it is likely to bring about a bigger drive current and higher motor temperature.

Torque boost diagram is shown in Fig. 6-43:

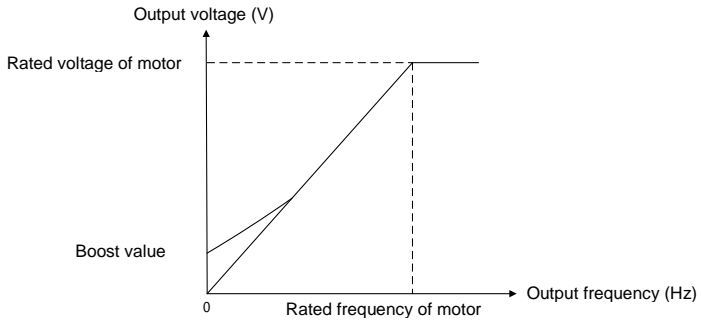

Fig. 6-43

d1-10	Slip compensation gain	Range: 0.0% - 400.0%	Factory default: 100.0%
-------	------------------------	----------------------	----------------------------

Used under V/f control. When the motor is driving an electric-driven load, motor speed drops with the increase of load. When the motor is driving a power generating load, motor speed will increase with the increase of load. Appropriate slip compensation gain can maintain constant motor speed when the motor load is changing.

To ensure the performance of slip compensation gain, setting motor rated speed d0-06 is essential. The difference between d0-06 and the motor running speed without load is the rated slip. Through real-time detection of motor load, slip compensation automatically adjusts the drive output frequency on the basis of rated slip and motor load, reducing the impact of changing load on motor speed.

Gain adjustment method: please make the adjustment around 100%. When motor is driving an electric-driven load: if motor speed is relatively lower, the gain should be appropriately increased; if motor speed is relatively higher, reduce the gain appropriately. When motor is driving a power generating load: if motor speed is relatively lower, the gain should be decreased; if motor speed is relatively higher, increase the gain appropriately.

Diagram of slip compensation gain is shown as Fig. 6-44 and 6-45.

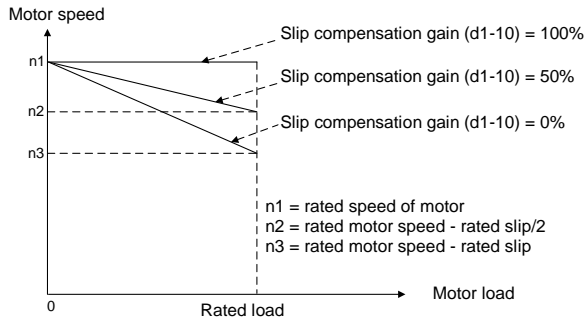

Fig. 6-44 Diagram of slip compensation on electric driven load

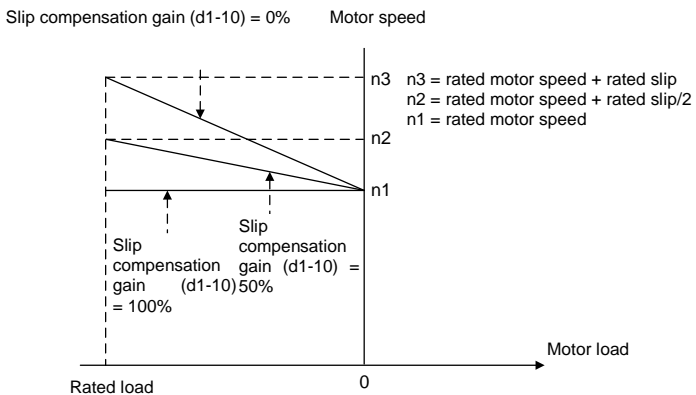

Fig. 6-45 Diagram of slip compensation on power generating load

d1-11	Drop FREQ control	Range: 0.00Hz - maximum frequency	Factory default: 0.00Hz
-------	-------------------	-----------------------------------	-------------------------

In case several drives drive one load, different drives may bear different proportion of the load. Through the setting of this parameter, the uniform load distribution on these drives could be attained.

The drive takes real-time detection of its load. Output frequency is automatically dropped according to the load and this parameter value, reducing itself borne load proportion. Parameter value of d1-11 corresponds to drop frequency with rated load.

d1-12	Current limitation mode	Range: 0 - 5	Factory default: 1
-------	-------------------------	--------------	--------------------

0: Disabled

1: Set by d1-13

2: Set by AI1

3: Set by AI2

4: Set by EAI

Drive output current is limited by analogue input in the range of " 0 - 200% x rated current of drive".

5: Set by X6/DI

Drive output current is limited by X6/DI pulse input in the range of "0 - 200% x rated current of drive".

When a non-zero value is set by d1-12, the current limitation is enabled. When output current rises dramatically because of sharp change of load, instant adjustment of output frequency will keep the output frequency below the set limitation. When the load is reduced, output frequency will recover promptly. If the setting speed or motor load change dramatically, this function can effectively reduce over-current fault.

When current limitation is enabled, the output frequency at constant speed may change at times and the Accel/Decel time may probably be automatically prolonged. Therefore, this function should not be used where output frequency or Accel/Decel time is not allowed to change.

d1-13	Digital setting of current limit value	Range: 20.0% - 200.0%	Factory default: 160.0%
-------	--	-----------------------	-------------------------

When d1-12 is set to "1: set by d1-13", the drive keeps output current less than this current limit value through instantaneous adjustment of output frequency. 100% current limit value corresponds to rated current of the drive. If this parameter value is set to a relatively big one, it will increase the chances of over-current. If this parameter value is set to a relatively small one, it will affect the loaded capability of the drive.

d1-14	Current limit coeff on flux weakening	Range: 0.001 - 1.000	Factory default: 0.500
-------	---------------------------------------	----------------------	------------------------

When the drive runs at the frequency higher than rated frequency of motor, Accel/Decel characteristic and output torque can be effectively improved by setting this parameter appropriately.

d1-15	Energy saving percentage	Range: 0% - 40.0%	Factory default: 0.0%
-------	--------------------------	-------------------	-----------------------

During no-load or light-load application, load current is detected so as to appropriately reduce output voltage, reducing the copper loss and iron loss of motor with the purpose of energy saving. The larger the energy-saving percentage is, the better the energy-saving effect will be, but the response will be slower. This parameter is applicable to loads such as fan and pump or light-load for a long time. Where rapid change is required, this parameter is suggested to be default set 0.0%.

d1-16	V/f oscillation suppression gain 1	Range: 0 - 3000	Factory default: 16
d1-17	V/f oscillation suppression gain 2	Range: 0 - 3000	Factory default: 20

Under V/f control, speed and current oscillation is likely to occur due to load vibration, and may lead to system failure even over current protection. This is particularly obvious during no-load or light-load applications. The appropriate setting of parameter values of d1-16 and d1-17 would effectively suppress speed and current oscillation. In many case it is not necessary to modify the default setting. Please make progressive change around default setting, since excessive setting will influence V/f control performance.

d1-18	Voltage setting on V/f separated pattern	Range: 0 - 5	Factory default: 0
-------	--	--------------	--------------------

This parameter takes effect when d1-00 is set to 7 or 8.

0: digital setting by d1-19

Under V/f separated pattern 1, drive output voltage is completely determined by d1-19. 100% corresponds to motor rated voltage.

Under V/f separated pattern 2, output voltage = voltage calculated according to linear V/f curve x 2 x d1-19.

- 1: Set by AI1
- 2: Set by AI2
- 3: Set by EAI

Under V/f separated pattern 1, drive output voltage is completely determined by the selected analogue. The biggest setting is the motor rated voltage.

Under V/f separated pattern 2, output voltage = voltage calculated according to linear V/f curve x the proportion determined by the analogue input. The maximum set value can be 200%.

4: Process PID output

Outputs voltage on the basis of process PID.

Under V/f separated pattern 1, output voltage is determined by the output of process PID.

Under V/f separated pattern 2, the output of process PID is a proportional value whose maximum set value could be 200%. Then this proportional value is multiplied by the voltage calculated according to linear V/f curve to obtain drive output voltage. Refer to parameter

group F0 for information of process PID.

5: AI1 + process PID output

Under V/f separated pattern 1, drive output voltage is determined by "AI1 + process PID output". The maximum set value of AI1 is motor rated voltage.

Under V/f separated pattern 2, "AI1 + process PID" output is a proportional value whose maximum set value corresponds to 200%. This proportional value is multiplied by the voltage calculated according to linear V/f to obtain drive output voltage.

d1-19	Digital set voltage on V/f separated pattern	Range: 0.0% - 100.0%	Factory default: 0.0%
-------	--	----------------------	-----------------------

When 0 is selected at d1-18, the output voltage will be determined by d1-19.

d1-20	Voltage variation time on V/f separated pattern	Range: 0.00s - 600.00s	Factory default: 0.01s
-------	---	------------------------	------------------------

Sets the output voltage change rate under V/f separation pattern. This parameter value is the time rising from 0V to motor rated voltage or dropping from rated voltage to 0V.

Group d2 Vector Control Parameters of Motor 1

Set control parameters in Group d2 when motor 1 is selected as current load motor on which sensor-less vector control is performed.

d2-00	Reserved	Reserved	Reserved
d2-01	ASR high-speed proportional gain Kp1	Range: 0.0 - 20.0	Factory default: 2.0
d2-02	ASR high-speed integration time Ti1	Range: 0.000s - 8.000s	Factory default: 0.200
d2-03	ASR low-speed proportional gain Kp2	Range: 0.0 - 20.0	Factory default: 2.0
d2-04	ASR low-speed integration time Ti2	Range: 0.000s - 8.000s	Factory default: 0.200
d2-05	ASR switching frequency 1	Range: 0.00Hz - d2-06	Factory default: 5.00Hz
d2-06	ASR switching frequency 2	Range: d2-05 - upper limiting frequency	Factory default: 10.00Hz

Under sensor-less vector control (SVC), motor speed is kept at set value by automatic speed regulator (ASR). ASR parameters should be set in d2-01 - d2-06.

The proportional gain Kp and integration time Ti of ASR can be set through d2-01 - d2-04 so as to change the speed response characteristic under SVC.

Increment of proportional gain K_p can bring in fast response of the system. However, bigger K_p value will bring about larger system oscillation.

Reduction of integration time T_i can also quicken response time, but small T_i value will result in big system overshooting and may easily bring about oscillation.

Principle for adjustment of proportional gain K_p and integration time T_i : proportional gain K_p is usually adjusted prior, maximizing K_p at the premise of ensuring the system is subject to no oscillation, and then adjust integration time T_i to provide the system with both instant response characteristic and less overshooting.

d2-01 - d2-02 are the proportional gain and integration time of the drive at high speed.

d2-03 - d2-04 are the proportional gain and integration time of the drive at low speed.

Distinction between high speed and low speed is determined by d2-05 - d2-06. The diagram is as shown in Fig. 6-46.

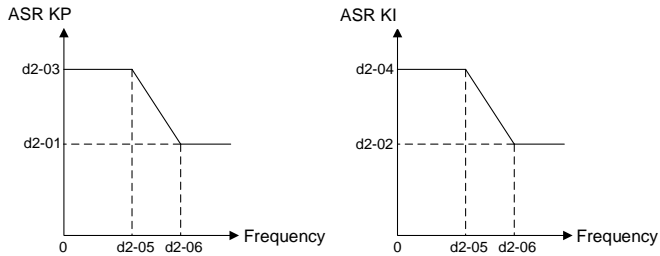

Fig. 6-46

ASR parameters are normally adjusted in the following order: select appropriate switching frequency. Adjust proportional gain d2-01 and integration time d2-02 at high speed, ensuring the system has no oscillation and meets the requirements of dynamic response characteristics. Adjust proportional gain d2-03 and integration time d2-04 at low speed, ensuring there is no oscillation at low speed and requirements of dynamic response characteristics are met.

& ATTENTION:

Inappropriate parameters of K_p , T_i may bring about overcurrent or overvoltage faults. Usually, fine adjustment should be performed close to factory default parameter.

d2-07	ASR input filtering time	Range: 0.0ms - 500.0ms	Factory default: 0.3ms
-------	--------------------------	------------------------	---------------------------

Sets the input filtering time of ASR. No need to modify its default setting if there is no special requirement.

d2-08	ASR output filtering time	Range: 0.0ms - 500.0ms	Factory default: 0.3ms
-------	---------------------------	------------------------	---------------------------

Sets the output filtering time of ASR. No need to modify its default setting if there is no special requirement.

d2-09	ACR proportion coefficient K_p	Range: 0.000 - 4.000	Factory default: 1.000
d2-10	ACR integration coefficient K_i	Range: 0.000 - 4.000	Factory default: 1.000

These two parameters determine the characteristics of automatic current regulator (ACR) under SVC pattern. Increment of proportion coefficient and/or integration coefficient can shorten torque response time. Reduction of proportion coefficient and/or integration coefficient can increase the stability of the system. Inappropriate setting may bring about system oscillation. Factory default is not needed to be changed in most cases.

d2-11	Pre-excitation time	Range: 0.000s - 5.000s	Factory default: 0.200s
-------	---------------------	------------------------	----------------------------

Applies to asynchronous motor. To attain quick start, it is necessary to perform pre-excitation before the running of motor, and the pre-excitation time is set by this parameter. Properly establish stable flux prior and then ramp up quickly. The set value of 0.000s means "no pre-excitation" and ramp up at the moment of the receipt of run command. Pre-excitation time is not included in Accel/Decel time. Factory default is suggested to maintain in most cases.

d2-12	Electric-driven torque limitation source	Range: 0 - 5	Factory default: 0
-------	--	--------------	--------------------

Under the pattern of SVC speed control, and when the motor is driving an electric-driven load, it usually needs to restrict the output torque of the motor. This parameter sets the limitation command source.

0: d2-14 digital setting

Restrict output torque through digital set parameter d2-14. 100% corresponds to motor rated torque.

1: Analogue input AI1

2: Analogue input AI2

3: Analogue input EAI

Limit the torque through analogue input. The limited range is "0 - 200%r x rated torque".

4: X6/DI pulse input

Restrict the torque through X6/DI pulse input. The limited range is "0 - 200%r x rated torque".

5: Communication

A superior device sets the limitation value of the output torque through standard RS485 communication interface at the drive. Refer to parameter Group H0 and appendix for details of communication.

d2-13	Brake torque limitation source	Range: 0 - 5	Factory default: 0
-------	--------------------------------	--------------	--------------------

Under the pattern of SVC speed control, and when the motor is driving a power generating load, it needs to restrict the output brake torque of the motor. This parameter sets the limitation command source.

0: d2-15 digital setting

Restrict output brake torque through digital set parameter d2-15. 100% corresponds to rated torque of the motor.

1: Analogue input AI1

2: Analogue input AI2

3: Analogue input EAI

Limit the torque through Analogue input. The limited range is "0 - 200%r x rated torque".

4: X6/DI pulse input

Restrict the torque through X6/DI pulse input. The limited range is "0 - 200%r x rated torque".

5: Communication

A superior device sets the limitation value of the output torque through standard RS485 communication interface at the drive. Refer to parameter Group H0 and appendix for details of communication.

d2-14	Digital setting of electric-driven torque	Range: 0.0% - 200.0%	Factory default: 180.0%
-------	---	----------------------	-------------------------

When 0 is selected for d2-12, this parameter value limits the maximum output electric-driven torque. 100% corresponds to rated torque of the motor.

d2-15	Digital setting of brake torque	Range: 0.0% - 200.0%	Factory default: 180.0%
-------	---------------------------------	----------------------	-------------------------

When 0 is selected for d2-13, this parameter value limits the maximum output brake torque. 100% corresponds to rated torque of the motor.

d2-16	Torque limit coefficient in flux weakening	Range: 0.0% - 100.0%	Factory default: 50.0%
-------	--	----------------------	------------------------

Under the pattern of SVC speed control, and when the drive is running at frequency higher than rated frequency (flux weakening zone), appropriate torque limit coefficient can effectively improve the performance of output torque and Accel/Decel characteristics.

d2-17	Electric-driven slip compensation gain	Range: 10.0% - 300.0%	Factory default: 100.0%
-------	--	-----------------------	-------------------------

Under SVC pattern, adjustment of this parameter value can improve the speed accuracy when driving electric-driven load. If the load is becoming heavier and the motor speed is relatively lower, set a bigger value, while the motor speed is relatively higher, set a smaller value.

d2-18	Brake slip compensation gain	Range: 10.0% - 300.0%	Factory default: 100.0%
-------	------------------------------	-----------------------	-------------------------

Under SVC pattern, adjustment of this parameter value can improve the speed accuracy when driving power generating load. If the load is becoming heavier and the motor speed is relatively higher, set a bigger value, while the motor speed is relatively lower, set a smaller value.

Group d3 Parameters of Motor 2

When motor 2 is selected as current loaded motor, set motor parameters in Group d3. The specification of parameters of motor 2 in Group d3 is exactly the same with that of parameters of motor 1 in Group d0.

d3-00	Type of motor 2	Range: 0 - 2	Factory default: 0
d3-01	Power rating of motor 2	Range: 0.4kW - 6553.5kW	Factory default: model defined
d3-02	Rated voltage of motor 2	Range: 0V - 480V	Factory default: 380V
d3-03	Rated current of motor 2	Range: 0.0A - 6553.5A	Factory default: model defined
d3-04	Rated frequency of motor 2	Range: 0.00Hz - 600.00Hz	Factory default: 50.00Hz
d3-05	Number of pole pairs of motor 2	Range: 1 - 80	Factory default: 4
d3-06	Rated speed of motor 2	Range: 0 - 65535 r/min	Factory default: model defined

d3-07	Stator resistance R1 of motor 2	Range: 0.001Ω - 65.535Ω	Factory default: model defined
d3-08	Leakage inductance L1 of motor 2	Range: 0.1mH - 6553.5mH	Factory default: model defined
d3-09	Rotor resistance R2 of motor 1	Range: 0.001Ω - 65.535Ω	Factory default: model defined
d3-10	Mutual inductance L2 of motor 2	Range: 0.1mH - 6553.5mH	Factory default: model defined
d3-11	No-load current of motor 2	Range: 0.0A - 6553.5A	Factory default: model defined
d3-12	Flux weakening coeff 1 of motor 2	Range: 0.0000 - 1.0000	Factory default: model defined
d3-13	Flux weakening coeff 2 of motor 2	Range: 0.0000 - 1.0000	Factory default: model defined
d3-14	Flux weakening coeff 3 of motor 2	Range: 0.0000 - 1.0000	Factory default: model defined
d3-22	Parameter identification of motor 2	Range: 0 - 2	Factory default: 0
d3-23	Overload protection mode of motor 2	Range: 0 - 2	Factory default: 1
d3-24	Overload protection detection time of motor 2	Range: 0.1min - 15.0min	Factory default: 5.0min
d3-25	Input channel of temperature transducer signal of motor 2	Range: 0 - 2	Factory default: 0
d3-26	Thermal protection threshold of temperature transducer for motor 2	Range: 0.00V - 10.00V	Factory default: 10.00V

Group d4 V/f Control Parameters of Motor 2

Set control parameters in Group d4 when motor 2 is selected as current loaded motor on which V/f control is performed. The specification of V/f control parameters of motor 2 in Group d4 is exactly the same with that of V/f control parameters of motor 1 in Group d1.

d4-00	V/f curve setting	Range: 0 - 8	Factory default: 0
d4-01	V/f frequency value f3	Range: 0.00Hz - rated frequency of motor	Factory default: 50.00Hz
d4-02	V/f voltage value V3	Range: 0.0% - 100.0%	Factory default: 100.0%
d4-03	V/f frequency value f2	Range: d4-05 - d4-01	Factory default: 0.00Hz
d4-04	V/f voltage value V2	Range: 0.0% - 100.0%	Factory default: 0.0%
d4-05	V/f frequency value f1	Range: d4-07 - d4-03	Factory default: 0.00Hz
d4-06	V/f voltage value V1	Range: 0.0% - 100.0%	Factory default: 0.0%
d4-07	V/f frequency value f0	Range: 0.00Hz - d4-05	Factory default: 0.00Hz
d4-08	V/f voltage value V0	Range: 0.0% - 100.0%	Factory default: 0.0%
d4-09	Torque boost	Range: 0.0% - 30.0%	Factory default: 0.0%
d4-10	Slip compensation gain	Range: 0.0% - 400.0%	Factory default: 100.0%
d4-11	Droop control	Range: 0.00Hz - maximum frequency	Factory default: 0.00Hz
d4-12	Current limitation mode	Range: 0 - 5	Factory default: 1
d4-13	Digital setting of current limit value	Range: 20.0% - 200.0%	Factory default: 160.0%
d4-14	Current limit coeff on flux weakening	Range: 0.001 - 1.000	Factory default: 0.500
d4-15	Energy saving percentage	Range: 0.0% - 40.0%	Factory default: 0.0%
d4-16	V/f oscillation suppression gain 1	Range: 0 - 3000	Factory default: 16

d4-17	V/f oscillation suppression gain 2	Range: 0 - 3000	Factory default: 20
d4-18	Voltage setting on V/f separated pattern	Range: 0 - 5	Factory default: 0
d4-19	Digital set voltage on V/f separated pattern	Range: 0.0% - 100.0%	Factory default: 0.0%
d4-20	Voltage variation time on V/f separated pattern	Range: 0.00s - 600.00s	Factory default: 0.01s

Group d5 Vector Control Parameters of Motor 2

Set control parameters in Group d5 when motor 2 is selected as current load motor on which SVC is performed. The specification of SVC parameters of motor 2 in Group d5 is exactly the same with that of SVC parameters of motor 1 in Group d3.

d5-00	Reserved	Reserved	Reserved
d5-01	ASR high-speed proportional gain Kp1	Range: 0.0 - 20.0	Factory default: 2.0
d5-02	ASR high-speed integration time Ti1	Range: 0.000s - 8.000s	Factory default: 0.200
d5-03	ASR low-speed proportional gain Kp2	Range: 0.0 - 20.0	Factory default: 2.0
d5-04	ASR low-speed integration time Ti2	Range: 0.000s - 8.000s	Factory default: 0.20
d5-05	ASR switching frequency 1	Range: 0.00Hz - d5-06	Factory default: 5.00Hz
d5-06	ASR switching frequency 2	Range: d5-05 - upper limiting frequency	Factory default: 10.00Hz
d5-07	ASR input filtering time	Range: 0.0ms - 500.0ms	Factory default: 0.3ms
d5-08	ASR output filtering time	Range: 0.0ms - 500.0ms	Factory default: 0.3ms
d5-09	ACR proportion coefficient Kp	Range: 0.000 - 4.000	Factory default: 1.000
d5-10	ACR integration coefficient Ki	Range: 0.000 - 4.000	Factory default: 1.000
d5-11	Pre-excitation time	Range: 0.000s - 5.000s	Factory default: 0.200s

d5-12	Electric-driven torque limitation source	Range: 0 - 5	Factory default: 0
d5-13	Limitation mode of braking torque	Range: 0 - 5	Factory default: 0
d5-14	Digital setting of electric-driven torque	Range: 0.0% - 200.0%	Factory default: 180.0%
d5-15	Digital setting of brake torque	Range: 0.0% - 200.0%	Factory default: 180.0%
d5-16	Torque limit coefficient in flux weakening	Range: 0.0% - 100.0%	Factory default: 50.0%
d5-17	Electric-driven slip compensation gain	Range: 10.0% - 300.0%	Factory default: 100.0%
d5-18	Brake slip compensation gain	Range: 10.0% - 300.0%	Factory default: 100.0%

Group E Enhancement Function and Protection Parameters

Group E0 Enhancement Function

E0-00	Carrier frequency	Range: 0.7 - 16.0kHz	Model defined
-------	-------------------	----------------------	---------------

With lower carrier frequency, output current of the drive produces higher harmonics, motor loss increases, and temperature and motor noise rise, but drive temperature, drive leakage current, and drive interference to external devices are lower or less.

with higher carrier frequency, drive temperature will rise, drive leakage current is bigger, and drive interference to external devices is bigger. However, motor loss and noise will be lower, and motor temperature will drop.

The table below specifies the setting range and factory default of PWM carrier frequency of the drives at different power ratings:

Table 6-16

Power rating of the drive	Setting Range	Factory Default
≤15kW	0.7k - 16k	8k

PWM carrier frequency setting method:

- 1) When the motor line is too long, reduce carrier frequency.
- 2) When torque at low speed is unstable, reduce carrier frequency.
- 3) If the drive produces severe interference to surrounding equipment, reduce carrier frequency.
- 4) Leakage current of the drive is big, reduce carrier frequency.
- 5) Drive temperature rise is relatively high, reduce carrier frequency.

- 6) Motor temperature rise is relatively high, increase carrier frequency.
 7) Motor noise is relatively big, increase carrier frequency.

E0-01	PWM optimization	Range: 0000 - 1121	Factory default: 100
-------	------------------	--------------------	-------------------------

U Unit's place: PWM carrier frequency adjusted with temperature

0: Automatic adjustment

1: No adjustment

When automatic adjustment of PWM carrier frequency is selected, the drive will automatically reduce carrier frequency with the temperature rise, protecting itself against overtemperature. Set to 1 where PWM carrier frequency change is not allowed.

U Decade: PWM modulation mode

0: five-segment and seven-segment automatic switchover

1: five-segment mode

2: seven-segment mode

This selection is valid only for V/f control. When five-segment mode is selected, the drive has low temperature rise but relatively higher output current harmonic. Under seven-segment mode, it has relatively higher temperature rise but lower output current harmonic. Under SVC pattern, PWM is seven-segment mode.

U Hundreds place: over-modulation adjustment

0: Disabled

1: Enabled

At low grid voltage or long-term heavy-duty operation, over-modulation can improve the voltage utilization and enhance the maximum voltage output capacity of the drive. This parameter takes effect only for V/f control, while over-modulation is enabled all the time under SVC pattern.

U Thousands place: PWM carrier frequency adjusted with frequency

0: Adjusted

1: No adjustment

E0-02	Command when running time attained	Range: 000 - 111	Factory default: 000
-------	------------------------------------	------------------	----------------------

└ Unit's place: command when consecutive running time attained

0: Continue to run

When consecutive running time of the drive attains the set value of E0-03, the drive will continue to run.

1: Stop and fault alarm

When consecutive running time of the drive attains the set value of E0-03, the drive will display fault code "to2" and coast to stop. Digital output terminal "consecutive running time attained" will output ON. When E0-03 is set to 0, this parameter value is enabled.

└ Decade: command when accumulative running time reached

0: Continue to run

When accumulative running time of the drive attains the set value of E0-04, the drive will continue to run.

1: Stop and fault alarm

When the accumulative running time of the drive attains the set value of E0-04, the drive will display fault code "to3" and coast to stop. Digital output terminal "accumulative running time attained" will output ON. When E0-04 is set to 0, this parameter value is enabled.

└ Hundreds place: unit of running time:

0: Second

1: Hour

Sets the unit of E0-03 consecutive running time and E0-04 accumulative running time.

E0-03	Consecutive running time	Range: 0.0 - 6000.0s(h)	Factory default: 0.0 s(h)
-------	--------------------------	-------------------------	---------------------------

When consecutive running time attains this set value, the drive will perform the action set by unit's place of E0-02. Time unit is set at hundreds place of E0-02. When this parameter value is set to 0, this function is enabled.

E0-04	Accumulative running time	Range: 0.0 - 6000.0s(h)	Factory default: 0.0 s(h)
-------	---------------------------	-------------------------	---------------------------

When accumulative running time of attains this set value, the drive will perform the action set by decade of E0-02. Time unit is set at hundreds place of E0-02. When this parameter value is set to 0, this function is enabled.

E0-05	Contracting brake control	Range: 0 - 1	Factory default: 0
-------	---------------------------	--------------	--------------------

0: Disabled

1: Enabled

Process of contracting brake control is as shown in Fig. 6-47 below:

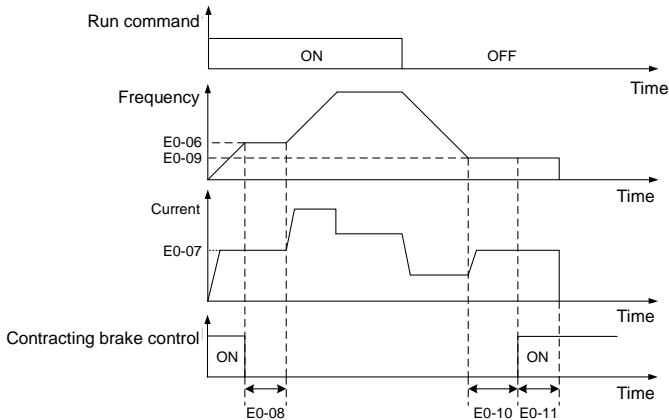

Fig. 6-47

- 1) Upon the receipt of run command, the drive will accelerate to the contracting brake release frequency set by E0-06.
- 2) When frequency attains the value as set by E0-06, digital output terminal "contracting brake control" outputs OFF to control the contracting brake release.
- 3) Perform constant-speed running at contracting brake release frequency. During this period, the drive keeps the output current no higher than the current as set by E0-07.
- 4) When the running time at contracting brake release frequency attains set value of E0-08, the drive will accelerate to set frequency.
- 5) Upon the receipt of stop command, the drive decelerate to contracting brake actuation frequency set by E0-09 and maintains constant-speed running at this frequency.
- 6) When the running frequency attains the set value of E0-09, waiting a period of time set by E0-10, then digital output terminal "contracting brake control" will output ON signal to control contracting brake actuation.
- 7) When the time of output ON signal "contracting brake control" attains the set value of E0-11, the drive will block the output and stop.

E0-06	Contracting brake release frequency	Range: 0.00Hz - 10.00Hz	Factory default: 2.50Hz
-------	-------------------------------------	-------------------------	-------------------------

When frequency attains this value, digital output terminal "contracting brake control" outputs OFF signal to control the release of contracting brake. This value can be set the same value as rated slip frequency of motor. Under V/f control, it could be set to a relatively large one.

E0-07	Contracting brake release current	Range: 0.0% - 200.0%	Factory default: 120.0%
-------	-----------------------------------	----------------------	-------------------------

Current is limited to this value before the drive starts its acceleration from contracting brake release frequency, in other words, before contracting brake mechanism is not completely released.

E0-08	Accel delay time after contracting brake release	Range: 0.0s - 10.0s	Factory default: 1.0s
-------	--	---------------------	-----------------------

After digital output terminal "contracting brake control" outputs OFF signal, inverter will delay its Accel with this time. Accelerated running will be started after this set time is elapsed. Please set this parameter value in compliance with the time required for mechanism release of contracting brake.

E0-09	Contracting brake suction frequency	Range: 0.00Hz - 10.00Hz	Factory default: 2.00Hz
-------	-------------------------------------	-------------------------	-------------------------

Upon the receipt of stop command, the drive decelerates to contracting brake suction frequency set by E0-09 and maintains constant-speed running at this frequency, waiting for the output of contracting brake control signal.

E0-10	Contracting brake suction waiting time	Range: 0.0s - 10.0s	Factory default: 0.0s
-------	--	---------------------	-----------------------

When the running frequency attains contracting brake suction frequency, after this waiting time, digital output terminal "contracting brake control" outputs ON signal to control the contracting brake suction.

E0-11	Contracting brake suction holding time	Range: 0.0s - 10.0s	Factory default: 1.0s
-------	--	---------------------	-----------------------

When the digital output terminal "contracting brake control" outputs ON signal, the frequency will be maintained the time set by E0-11 to ensure complete mechanism suction. Then, the drive will block the output and stop.

Group E1 Protection Parameters

E1-00	Overvoltage stall	Range: 0 - 1	Factory default: 1
-------	-------------------	--------------	--------------------

0: Prohibited

1: Allowed

When the motor is decelerating with a high-inertia load or short-term regenerative braking occurs during the running, the energy feedback to the drive may raise DC bus voltage, and thus resulting in overvoltage protection.

When this parameter value is set to 1, the drive will detect its bus voltage and compare with parameter set by E1-01. If the bus voltage exceeds value of E1-01, drive output frequency shall be adjusted instantaneously and the deceleration time shall be automatically prolonged, to maintain the stability of DC bus voltage. Set this parameter to 0 if frequency fluctuation or Decel time prolonging is not allowed.

E1-01	Overvoltage stall protection voltage	Range: 120% - 150%	Factory default: 135%
-------	--------------------------------------	--------------------	-----------------------

This value is a percentage compared to standard DC bus voltage.

E1-02	Undervoltage stall	Range: 0 - 1	Factory default: 0
-------	--------------------	--------------	--------------------

0: Disabled

1: Enabled

Under momentary voltage drop or momentary power loss, the drive will accordingly drop output frequency, and compensate the voltage drop via the energy feedback from load, so as to maintain consecutive running, no trip. This function applies to fans and centrifugal pumps and such.

E1-03	Overload alarm	Range: 000 - 111	Factory default: 000
-------	----------------	------------------	----------------------

□ Unit's place: detection option

0: Always detect

Overload alarm works all the time during drive running.

1: Detect at constant speed only

Overload pre-alarm only works during constant-speed running of inverter.

□ Decade: compared object

0: Rated current of motor

Compared object is the rated current relative to motor, and display "oL2" when the alarm is given under this setting

1: Rated current of drive

Compared object is the rated current of drive, and display "oL1" when the alarm is given under this setting.

□ Hundreds place: alarm option

0: Alarm and continue to run

When drive output current exceeds the level set by E1-04 and the lasting time attains parameter value of E1-05, the drive will alarm but continue its running.

1: Protection enabled and coast to stop

When drive output current exceeds the level set by E1-04 and the lasting time attains parameter value of E1-05, the drive will display overload fault and coast to stop.

E1-04	Overload alarm threshold	Range: 20.0% - 200.0%	Factory default: 130.0%
-------	--------------------------	-----------------------	----------------------------

When 0 is set at decade of E1-03, this set value is a percentage compared to rated current of motor. When 1 is set of that, this set value is a percentage compared to rated current of drive.

E1-05	Overload alarm activated time	Range: 0.1s - 60.0s	Factory default: 5.0s
-------	-------------------------------	---------------------	--------------------------

Sets the lasting time that overload alarm is activated when output current of drive is bigger than the threshold set by E1-04.

E1-06	Protection action 1	Range: 0000 - 1111	Factory default: 0000
E1-07	Protection action 2	Range: 0000 - 3111	Factory default: 0000

These two parameters set the protection action of the drive in the following abnormal status.

Specification of E1-06:

- ┌ Unit's place: reserved
- ┌ Decade: temperature sampling disconnection action
- 0: Protection enabled and coast to stop
- 1: Alarm and continue to run
- ┌ Hundreds place: abnormal EEPROM
- 0: Protection enabled and coast to stop
- 1: Alarm and continue to run
- ┌ Thousands place: abnormal terminal communication
- 0: Protection enabled and coast to stop
- 1: Alarm and continue to run

Specification of E1-07:

- ┌ Unit's place: abnormal keypad communication
- 0: Protection enabled and coast to stop
- 1: Alarm and continue to run
- ┌ Decade: current detection circuit failed
- 0: Protection enabled and coast to stop
- 1: Alarm and continue to run
- ┌ Hundreds place: abnormal contactor
- 0: Protection enabled and coast to stop
- 1: Alarm and continue to run
- ┌ Thousands place: input/output phase loss
- 0: Protection disabled for input phase loss; protection disabled for output phase loss
- 1: Protection disabled for input phase loss; protection enabled for output phase loss
- 2: Protection enabled for input phase loss; protection disabled for output phase loss

3: Protection enabled for input phase loss; protection enabled for output phase loss

& ATTENTION:

Please set "protection action" with caution since inappropriate setting may extend the fault

E1-08	Fault memory after power loss	Range: 0 - 1	Factory default: 0
-------	-------------------------------	--------------	--------------------

Determine whether or not the previous fault code is to be memorized and displayed upon the power up of the drive after power loss.

0: Not memorized after power loss

1: Memorized after power loss

& ATTENTION:

Undervoltage fault "LoU" is not memorized after power loss.

E1-09	Times of automatic reset	Range: 0 - 20	Factory default: 0
E1-10	Interval of automatic reset	Range: 2.0s - 20.0s	Factory default: 2.0s

When a fault occurs during the running, the drive will run at 0Hz with the time set by E1-10, and then the fault will be reset and the drive continues to run. Times of automatic reset is set by E1-09. Automatic reset is prohibited and fault protection shall be executed immediately when E1-09 is set to 0.

& ATTENTION:

1) Automatic fault reset is not performed at the following types of faults:

Module protection "FAL"

Parameter identification failed "tUN"

Current detection abnormal "CtC"

Ground short circuit protection at output side "GdP"

Converter module overload protection "oL3"

Expansion board 1 connection abnormal "EC1"

Expansion board 2 connection abnormal "EC2"

Drive line connection abnormal "dLC"

External equipment error "PEr"

Consecutive running time attained "to2"

Accumulative running time attained fault "to3"

Power supply abnormal during running "SUE"

Parameter copy fault "CPy"

Software version compatibility failure "SFT"

CPU interference fault "CPU"

Reference protection "oCr"
 5V power supply out-of-limit "SP1"
 Undervoltage protection "LoU"

2) Please use automatic fault reset function with caution, or fault expansion may occur.

E1-11	Relay action on drive fault	Range: 000 - 111	Factory default: 010
-------	-----------------------------	------------------	-------------------------

U Unit's place: when undervoltage fault occurs

0: No action

1: Action enabled

Set whether or not fault relay acts when undervoltage occurs.

U Decade: when fault locked

0: No action

1: Action enabled

Set whether or not the relay acts when the fault locked at latest power loss after power up.

U Hundred's place: time of automatic reset

0: No action

1: Action enabled

Set whether or not the relay is to operate when fault occurs in automatic reset status.

E1-12	Cooling fan control	Range: 0 - 1	Factory default: 0
-------	---------------------	--------------	--------------------

0: Auto run

The fans run all the time during the running. Determine if the fans continue to run or stop according to module temperature after stop.

1: Always run

The fans run all the time after applying power to the drive.

E1-13	Drive thermal alarm threshold	Range: 0.0 °C - 100.0 °C	Factory default: 70.0
-------	-------------------------------	--------------------------	--------------------------

Sets the threshold of drive thermal alarm. When the maximum internal temperature of drive is higher than this value, the drive displays thermal alarm code "oH1", but won't influence the running.

Group F Application

Group F0 Process PID

The purpose of process PID control is to make feedback value consistent with the set value. PID control diagram is as shown in Fig. 6-48.

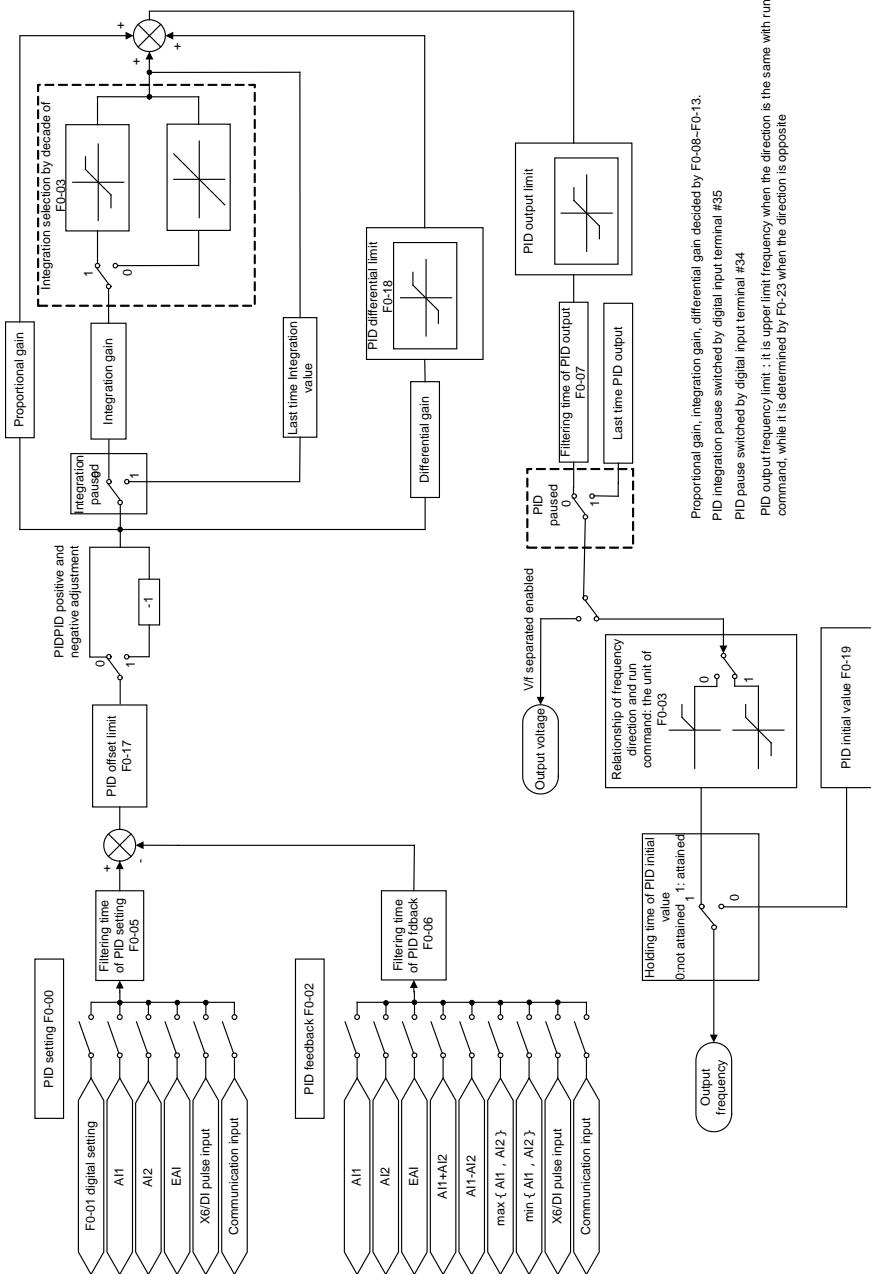

Fig. 6-48

F0-00	PID setting	Range: 0 - 5	Factory default: 0
-------	-------------	--------------	--------------------

Select the setting source of PID control.

0: F0-01 digital setting

1:AI1

2:AI2

3: EAI (on IO expansion board)

4: X6/DI pulse input

5: Communication

F0-01	PID digital setting	Range: 0.0% - 100.0%	Factory default: 50.0%
-------	---------------------	----------------------	---------------------------

When F0-00 is set to 0, this parameter value is taken as set value of PID.

F0-02	PID feedback	Range: 0 - 8	Factory default: 0
-------	--------------	--------------	--------------------

Select the feedback source of PID control.

0:AI1

1:AI2

2: EAI (on IO expansion board)

3:AI1+AI2

4:AI1-AI2

5:max { AI1 , AI2 }

6:min { AI1 , AI2 }

7: X6/DI pulse input

8: Communication

F0-03	PID adjustment	Range: 00 - 11	Factory default: 11
-------	----------------	----------------	---------------------

□ Unit's place: output frequency

0: Must be the same direction as setting running direction

When PID frequency output direction is opposite to run command direction, PID output is 0.

1: Opposite direction allowed

PID frequency output direction can be opposite to run command direction, and PID output performs normally.

□ Decade: integration selection

0: Integral continued when frequency attains upper/lower frequency

Under PID control, when output frequency attains upper/lower limit of frequency or parameter value of F0-23 (maximum frequency if it is opposite to command running direction), PID integral continues. This mode requires longer time of quitting saturation.

1: Integral stopped when frequency attains upper/lower limit

Under PID control, when output frequency attains upper/lower limit of frequency or

parameter value of F0-23 (maximum frequency if it is opposite to command running direction), PID integral will cease. This mode can quit integral saturation status rapidly.

F0-04	PID positive and negative adjustment	Range: 0 - 1	Factory default: 0
-------	--------------------------------------	--------------	--------------------

0: Positive adjustment

1: Negative adjustment

This parameter can be used with digital input terminal "PID adjustment direction" to select positive or negative adjustment of PID.

Table 6-17

F0-04	PID adjustment direction terminal	Adjustment
0	OFF	Positive
0	ON	Negative
1	OFF	Negative
1	ON	Positive

Positive adjustment: when feedback signal is smaller than PID setting, output frequency of the drive will rise to reach PID balance.

when feedback signal is bigger than PID setting, output frequency of the drive will drop to reach PID balance.

Negative adjustment: when feedback signal is smaller than PID setting, output frequency of the drive will drop to reach PID balance.

when feedback signal is bigger than PID setting, output frequency of the drive will rise to reach PID balance.

F0-05	Filtering time of PID setting	Range: 0.00s - 60.00s	Factory default: 0.00s
F0-06	Filtering time of PID feedback	Range: 0.00s - 60.00s	Factory default: 0.00s
F0-07	Filtering time of PID output	Range: 0.00s - 60.00s	Factory default: 0.00s

Set the filtering time of PID setting, feedback and output.

F0-08	Proportional gain Kp1	Range: 0.0 - 100.0	Factory default: 2.0
F0-09	Integration time Ti1	Range: 0.0s - 100.0s	Factory default: 1.0s
F0-10	Differential time Td1	Range: 0.0s - 100.0s	Factory default: 0.0s

Process PID is provided with two groups of proportion, integral and differential parameters set by F0-14. F0-08 - F0-10 are the first group of parameters.

Proportional gain Kp: dynamic response of the system can be quickened by increasing proportional gain Kp. However, excessive Kp value would bring about system oscillation. Only proportional gain control cannot eliminate steady state error.

Integration time: dynamic response of the system can be quickened by reducing integration time Ti. However, excessively small Ti value would result in serious system overshooting and may easily bring about oscillation. Integral control can be used to eliminate steady state error but is unable to control sharp changes.

Differential time Td: it can predict the change trend of offset and thus can rapidly respond to the change, improving dynamic performance. However, this is vulnerable to interference. Please use differential control with caution.

F0-11	Proportional gain Kp2	Range: 0.0 - 100.0	Factory default: 2.0
F0-12	Integration time Ti2	Range: 0.0s - 100.0s	Factory default: 1.0s
F0-13	Differential time Td2	Range: 0.0s - 100.0s	Factory default: 0.0s

Process PID is provided with two groups of proportion, integral and differential parameters set by F0-14. F0-11 - F0-13 are the second group of parameters.

F0-14	PID parameter switchover	Range: 0 - 2	Factory default: 0
-------	--------------------------	--------------	--------------------

Process PID is provided with two groups of proportional, integral and differential parameters, which is set by this parameter.

0: No switch, determined by parameters Kp1, Ti1 and Td1

Always determined by Kp1, Ti1 and Td1 set at F0-08 - F0-10.

1: Auto switched on the basis of input offset

When the offset between setting and feedback is less than the set value of F0-15, PID adjustment is determined by Kp1, Ti1 and Td1. When the offset between setting and feedback is bigger than the set value of F0-15, PID adjustment is determined by Kp2, Ti2 and Td2 set at F0-11 - F0-13.

2: Switched by terminal

When digital input terminal "PID parameters switch" is OFF, it is determined by Kp1, Ti1 and Td1. When "PID parameters switch" is ON, it is determined by Kp2, Ti2 and Td2

F0-15	Input offset under PID auto switch	Range: 0.0% - 100.0%	Factory default: 20.0%
-------	---------------------------------------	----------------------	---------------------------

When F0-14 is set to 1, this parameter sets the switching point of the two groups of PID parameters.

When the offset between setting and feedback is less than this set value, it is determined by Kp1, Ti1 and Td1.

When the offset between setting and feedback is bigger than this set value, it is determined by Kp2, Ti2 and Td2.

F0-16	Sampling period T	Range: 0.001s - 50.000s	Factory default: 0.002s
-------	-------------------	-------------------------	----------------------------

Sampling period aims at feedback. PID controller performs the sampling and compute once in each sampling period. The longer the sampling period T is, the slower the response time will be.

F0-17	PID offset limit	Range: 0.0% - 100.0%	Factory default: 0.0%
-------	------------------	----------------------	--------------------------

If the offset between PID feedback and setting is more than this set value, PID regulator will implement regulation. If the offset between PID feedback and setting is less than this set value, PID will stop the regulation and the PID controller output will be kept unchanged. This function can improve the stability of PID performance.

F0-18	PID differential limit	Range: 0.0% - 100.0%	Factory default: 0.5%
-------	------------------------	----------------------	--------------------------

Sets differential output limit of PID control.

F0-19	PID initial value	Range: 0.0% - 100.0%	Factory default: 0.0%
F0-20	Holding time of PID initial value	Range: 0.0s - 3600.0s	Factory default: 0.0s

PID does not make adjustment when the drive starts its running, but outputs the value set by F0-19 and maintains the holding time set by F0-20, then starts PID adjustment. When F0-20 is set to 0, PID initial value is disabled. This function makes PID adjustment get into stable status fast.

F0-21	PID feedback loss detection value	Range: 0.0% - 100.0%	Factory default: 0.0%
F0-22	PID feedback loss detection time	Range: 0.0s - 30.0s	Factory default: 1.0s

When offset between feedback and setting of PID is bigger than set value of F0-21 and the lasting time attains the set time of F0-22, the drive reports fault "Plo". If F0-22 is set to 0, feedback loss detection is disabled.

F0-23	Maximum FREQ when opposite to command direction	Range: 0.00Hz - maximum frequency	Factory default: 50.00Hz
-------	---	-----------------------------------	--------------------------

When run command direction is forward, while PID output is reverse, the maximum reverse frequency will be determined by F0-23.

When run command direction is reverse, while PID output is forward, the maximum forward frequency will be determined by F0-23.

F0-24	PID computation option	Range: 0 - 1	Factory default: 0
-------	------------------------	--------------	--------------------

- 0: No computation in stop status
- 1: Computation continued in stop status

Group F1 Multi-step Frequency

F1-00	Frequency command source of multi-step 0	Range: 0 - 8	Factory default: 0
-------	--	--------------	--------------------

- 0: Digital setting F1-02
- 1: Digital setting b0-02 + keypad \wedge / v adjustment
- 2: Digital setting b0-02 + terminal UP/DOWN adjustment
- 3:A11
- 4:A12
- 5: EAI (on IO expansion board)
- 6: X6/DI pulse input
- 7: Process PID output
- 8: Communication

At most 16-step of frequency can be set through the combination of "multi-step frequency terminals 1 - 4" of digital input. Multi-step frequency 2 - 15 are only digital setting while a number of setting sources can be selected for multi-step frequency 0 - 1. Parameter value of F1-00 determines command source of step 0.

F1-01	Frequency command source of multi-step 1	Range: 0 - 8	Factory default: 0
-------	--	--------------	--------------------

- 0: Digital setting F1-03
- 1: Digital setting b0-04 + keypad \wedge / v adjustment
- 2: Digital setting b0-04 + terminal UP/DOWN adjustment
- 3:A11
- 4:A12
- 5: EAI (on IO expansion card)
- 6: X6/DI pulse input
- 7: Process PID output

8: Communication

At most 16-step of frequency can be set through the combination of "multi-step frequency terminals 1 - 4" of digital input. Multi-step frequency 2 - 15 are only digital setting while a number of setting sources can be selected for multi-step frequency 0 - 1. Parameter value of F1-01 determines command source of step 1.

F1-02	Multi-step frequency 0	Lower limit frequency - upper limit frequency	Factory default: 0.00Hz
F1-03	Multi-step frequency 1	Lower limit frequency - upper limit frequency	Factory default: 0.00 Hz
F1-04	Multi-step frequency 2	Lower limit frequency - upper limit frequency	Factory default: 0.00 Hz
F1-05	Multi-step frequency 3	Lower limit frequency - upper limit frequency	Factory default: 0.00 Hz
F1-06	Multi-step frequency 4	Lower limit frequency - upper limit frequency	Factory default: 0.00 Hz
F1-07	Multi-step frequency 5	Lower limit frequency - upper limit frequency	Factory default: 0.00 Hz
F1-08	Multi-step frequency 6	Lower limit frequency - upper limit frequency	Factory default: 0.00 Hz
F1-09	Multi-step frequency 7	Lower limit frequency - upper limit frequency	Factory default: 0.00 Hz
F1-10	Multi-step frequency 8	Lower limit frequency - upper limit frequency	Factory default: 0.00 Hz
F1-11	Multi-step frequency 9	Lower limit frequency - upper limit frequency	Factory default: 0.00 Hz
F1-12	Multi-step frequency 10	Lower limit frequency - upper limit frequency	Factory default: 0.00 Hz
F1-13	Multi-step frequency 11	Lower limit frequency - upper limit frequency	Factory default: 0.00 Hz
F1-14	Multi-step frequency 12	Lower limit frequency - upper limit frequency	Factory default: 0.00 Hz
F1-15	Multi-step frequency 13	Lower limit frequency - upper limit frequency	Factory default: 0.00 Hz
F1-16	Multi-step frequency 14	Lower limit frequency - upper limit frequency	Factory default: 0.00 Hz
F1-17	Multi-step frequency 15	Lower limit frequency - upper limit frequency	Factory default: 0.00 Hz

At most 16 steps of multi-step frequency can be set by different status combinations of "multi-step frequency terminals 1 - 4" of digital input, as shown in Table 6-18.

Table 6-18

Multi-step terminal 4	Multi-step terminal 3	Multi-step terminal 2	Multi-step terminal 1	Command frequency
OFF	OFF	OFF	OFF	Multi-step frequency 0(F1-00)
OFF	OFF	OFF	ON	Multi-step frequency 1(F1-01)
OFF	OFF	ON	OFF	Multi-step frequency 2(F1-04)
OFF	OFF	ON	ON	Multi-step frequency 3(F1-05)
OFF	ON	OFF	OFF	Multi-step frequency 4(F1-06)
OFF	ON	OFF	ON	Multi-step frequency 5(F1-07)
OFF	ON	ON	OFF	Multi-step frequency 6(F1-08)
OFF	ON	ON	ON	Multi-step frequency 7(F1-09)
ON	OFF	OFF	OFF	Multi-step frequency 8(F1-10)
ON	OFF	OFF	ON	Multi-step frequency 9(F1-11)
ON	OFF	ON	OFF	Multi-step frequency 10(F1-12)
ON	OFF	ON	ON	Multi-step frequency 11(F1-13)
ON	ON	OFF	OFF	Multi-step frequency 12(F1-14)
ON	ON	OFF	ON	Multi-step frequency 13(F1-15)
ON	ON	ON	OFF	Multi-step frequency 14(F1-16)
ON	ON	ON	ON	Multi-step frequency 15(F1-17)

Group F2 Simple PLC

Simple PLC is a multi-step frequency generator. The drive can automatically change running frequency and direction based on running time so as to meet on-site technological requirements. Flow chart is shown as Fig. 6-49.

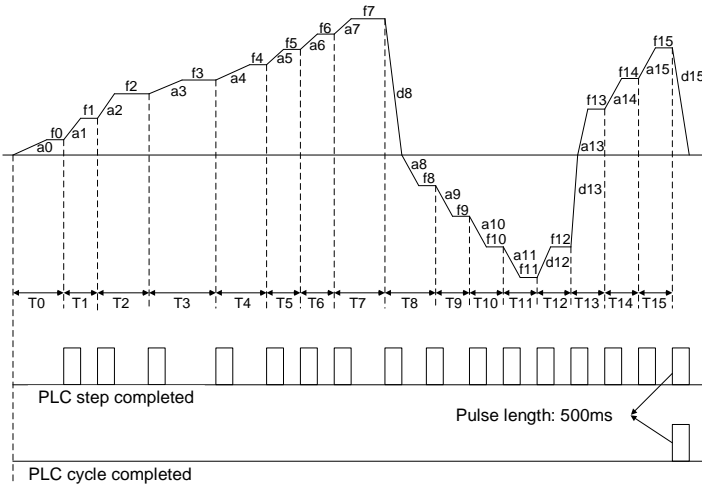

Fig. 6-49

a0 - a15 are the Accel times of steps, while d0 - d15 are the Decel times.

f0 - f15 are the set frequencies of steps while T0 - T15 are the running times.

Upon the completion of current step of simple PLC, digital output terminal "PLC step completed" outputs ON signal, 500ms.

When simple PLC finishes a running cycle, digital output terminal "PLC cycle completed" outputs ON signal, 500ms.

F2-00	Running mode of simple PLC	Range: 0000 - 1212	Factory default: 0000
-------	----------------------------	--------------------	-----------------------

u Unit's place: PLC running mode

0: Stop after a single cycle

PLC stops upon the completion of one cycle and it won't be started unless another run command is given, shown as Fig. 6-50.

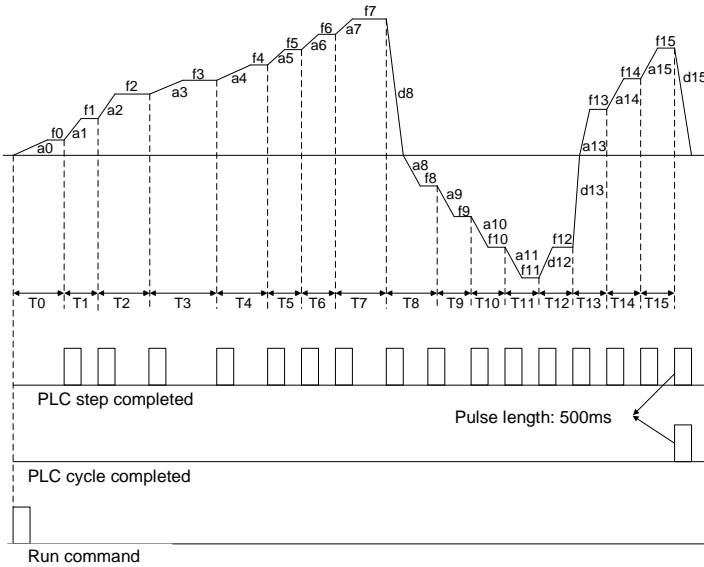
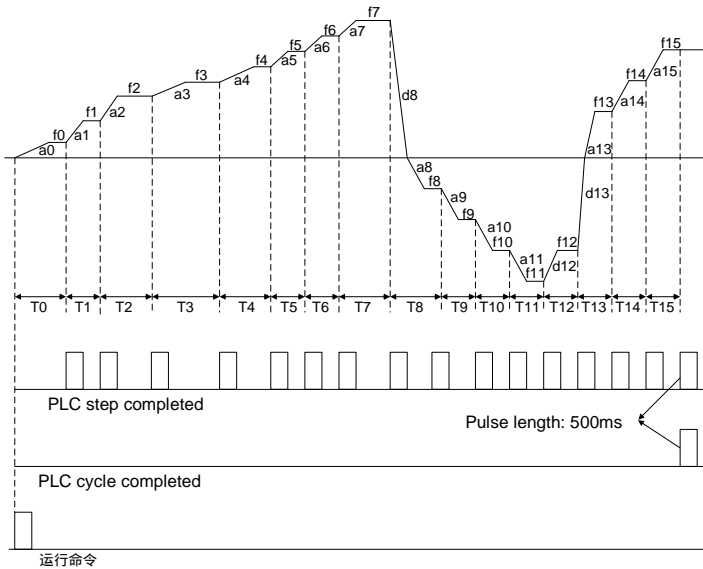

Fig. 6-50

1: Continue to run with the last frequency after a single cycle

After the completion of one cycle, PLC maintains the running frequency and direction of the last step. See the figure below:



Run command

Fig. 6-51

2: Repeat cycles

PLC automatically starts the another cycle after finishing one until there is a stop command, shown as Fig. 6-52.

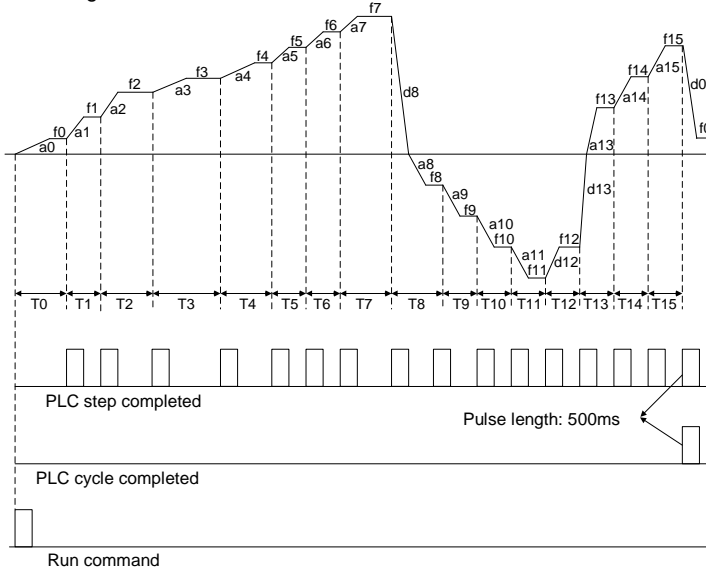

Fig. 6-52

U Decade: power loss memory

0: Memory disabled on power loss

The drive does not memorize PLC running status on power loss and starts the running from step 0 after power up again.

1: Memory enabled on power loss

The drive saves PLC running status on power loss, including the running step, running frequency and finished running time at the moment of power loss. After the next power up, the running will be continued in accordance with the memorized status.

U Hundreds place: started mode

0: Run from the first step "multi-step frequency 0"

When restarted after stop, the drive will start to run from "step 0".

1: Continue to run from the step of stop (or fault)

At the moment drive stop, the drive automatically records the running time of current step. When restarted, the drive will gets into this step, continue to run the remanent time with the frequency of this step, shown as Fig. 6-53.

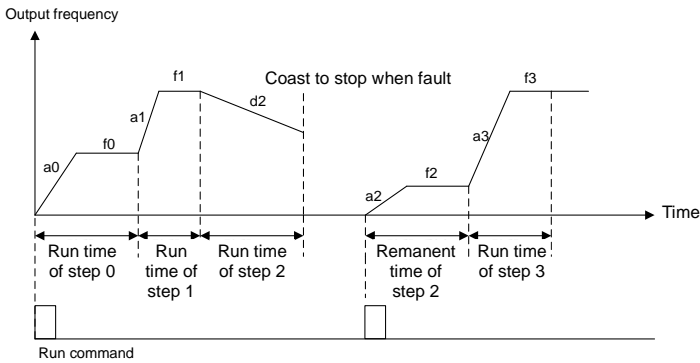

Fig. 6-53

2: Continue to run from the step and frequency at which the running stopped (or fault occurred)
 At the moment of stop, the drive not only records the running time of current step, but also records the running frequency at the moment of stop. When restarted, it will restore the running frequency that was recorded at the moment of stop, and then continue to run the remanent step, as shown in Fig. 6-54:

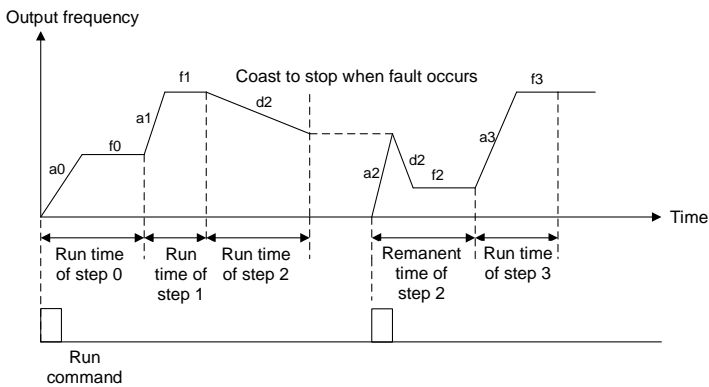

Fig. 6-54

U Thousands place: unit of simple PLC running time
 0: Second
 1: Minute
 Sets the unit of running time and Accel/Decel time of simple PLC.

F2-01	Setting of multi-step 0	Range: 000 - 327	Factory default: 000
-------	-------------------------	------------------	-------------------------

└ Unit's place: frequency command
Sets the frequency command of step 0 of simple PLC.

0: Multi-step frequency 0 (F1-02)

1:A11

2:A12

3: EAI (on IO expansion board)

4: X6/DI pulse input

5: Process PID output

6: Multi-step frequency

7: Communication

└ Decade: running direction

Sets the running direction for step 0 of simple PLC.

0: Forward

1: Reverse

2: Determined by run command

└ Hundreds place: Accel/Decel time option

Sets the Accel/Decel time step 0.

0: Accel/Decel time 1

1: Accel/Decel time 2

2: Accel/Decel time 3

3: Accel/Decel time 4

The Accel/Decel time of simple PLC running is set here, not determined by digital input terminal "Accel/Decel time determinant 1 - 2". In addition, Accel/Decel time unit is set through thousands place of F2-00 and is independent of the setting of b2-00.

F2-02	Running time of step 0	Range: 0.0 - 6000.0s(min)	Factory default: 0.0s
-------	------------------------	---------------------------	--------------------------

Sets the running time for step 0 of simple PLC and the time unit is set by thousands place of F2-00.

F2-03	Setting of step 1	Range: 000 - 327	Factory default: 000
-------	-------------------	------------------	-------------------------

└ Unit's place: frequency setting

0: Multi-step frequency 1 (F1-03)

1 - 7: same as F2-01

└ Decade: running direction (same as F2-01)

└ Hundreds place: Accel/Decel time option (same as F2-01)

F2-04	Running time of step 1	Range: 0.0 - 6000.0s(min)	Factory default: 0.0s
-------	------------------------	---------------------------	--------------------------

Sets the running time for step 1 of simple PLC and the time unit is set by thousands place of F2-00.

F2-05	Setting of step 2	Range: 000 - 327	Factory default: 000
-------	-------------------	------------------	-------------------------

U Unit's place: frequency setting

0: Multi-step frequency 2 (F1-04)

1 - 7: same as F2-01

U Decade: running direction (same as F2-01)

U Hundreds place: Accel/Decel time option (same as F2-01)

F2-06	Running time of step 2	Range: 0.0 - 6000.0s(min)	Factory default: 0.0s
-------	------------------------	---------------------------	--------------------------

Sets the running time of step 2. The time unit is set by thousands place of F2-00.

F2-07	Setting of step 3	Range: 000 - 327	Factory default: 000
-------	-------------------	------------------	-------------------------

U Unit's place: frequency setting

0: Multi-step frequency 3 (F1-05)

1 - 7: same as F2-01

U Decade: running direction (same as F2-01)

U Hundreds place: Accel/Decel time option (same as F2-01)

F2-08	Running time of step 3	Range: 0.0 - 6000.0s(min)	Factory default: 0.0s
-------	------------------------	---------------------------	--------------------------

Sets the running time of step 3 of simple PLC. The time unit is set by thousands place of F2-00.

F2-09	Setting of step 4	Range: 000 - 327	Factory default: 000
-------	-------------------	------------------	-------------------------

U Unit's place: frequency setting

0: Multi-step frequency 4 (F1-06)

1 - 7: same as F2-01

U Decade: running direction (same as F2-01)

U Hundreds place: Accel/Decel time option (same as F2-01)

F2-10	Running time of step 4	Range: 0.0 - 6000.0s(min)	Factory default: 0.0s
-------	------------------------	---------------------------	--------------------------

Sets the running time of step 4 of simple PLC. The time unit is set by thousands place of F2-00.

F2-11	Setting of step 5	Range: 000 - 327	Factory default: 000
-------	-------------------	------------------	-------------------------

⌋ Unit's place: frequency setting

0: Multi-step frequency 5 (F1-07)

1 - 7: same as F2-01

⌋ Decade: running direction (same as F2-01)

⌋ Hundreds place: Accel/Decel time option (same as F2-01)

F2-12	Running time of step 5	Range: 0.0 - 6000.0s(min)	Factory default: 0.0s
-------	------------------------	---------------------------	--------------------------

Sets the running time of step 5 of simple PLC. The time unit is set by thousands place of F2-00.

F2-13	Setting of step 6	Range: 000 - 327	Factory default: 000
-------	-------------------	------------------	-------------------------

⌋ Unit's place: frequency setting

0: Multi-step frequency 6 (F1-08)

1 - 7: same as F2-01

⌋ Decade: running direction (same as F2-01)

⌋ Hundreds place: Accel/Decel time option (same as F2-01)

F2-14	Running time of step 6	Range: 0.0 - 6000.0s(min)	Factory default: 0.0s
-------	------------------------	---------------------------	--------------------------

Sets the running time of step 6 of simple PLC. The time unit is set by thousands place of F2-00.

F2-15	Setting of step 7	Range: 000 - 327	Factory default: 000
-------	-------------------	------------------	-------------------------

⌋ Unit's place: frequency setting

0: Multi-step frequency 7 (F1-09)

1 - 7: same as F2-01

⌋ Decade: running direction (same as F2-01)

⌋ Hundreds place: Accel/Decel time option (same as F2-01)

F2-16	Running time of step 7	Range: 0.0 - 6000.0s(min)	Factory default: 0.0s
-------	------------------------	---------------------------	--------------------------

Sets the running time of step 7 of simple PLC. The time unit is set by thousands place of F2-00.

F2-17	Setting of step 8	Range: 000 - 327	Factory default: 000
-------	-------------------	------------------	-------------------------

⌋ Unit's place: frequency setting

0: Multi-step frequency 8 (F1-10)

1 - 7: same as F2-01

⌋ Decade: running direction (same as F2-01)

⌋ Hundreds place: Accel/Decel time option (same as F2-01)

F2-18	Running time of step 8	Range: 0.0 - 6000.0s(min)	Factory default: 0.0s
-------	------------------------	---------------------------	--------------------------

Sets the running time of step 8 of simple PLC. The time unit is set by thousands place of F2-00.

F2-19	Setting of step 9	Range: 000 - 327	Factory default: 000
-------	-------------------	------------------	-------------------------

⌋ Unit's place: frequency setting

0: Multi-step frequency 9 (F1-11)

1 - 7: same as F2-01

⌋ Decade: running direction (same as F2-01)

⌋ Hundred's place: Accel/Decel time option (same as F2-01)

F2-20	Running time of step 9	Range: 0.0 - 6000.0s(min)	Factory default: 0.0s
-------	------------------------	---------------------------	--------------------------

Sets the running time for step 9 of simple PLC. The time unit is set by thousands place of F2-00.

F2-21	Setting of step 10	Range: 000 - 327	Factory default: 000
-------	--------------------	------------------	-------------------------

⌋ Unit's place: frequency setting

0: Multi-step frequency 10 (F1-12)

1 - 7: same as F2-01

⌋ Decade: running direction (same as F2-01)

⌋ Hundreds place: Accel/Decel time option (same as F2-01)

F2-22	Running time of step 10	Range: 0.0 - 6000.0s(min)	Factory default: 0.0s
-------	-------------------------	---------------------------	--------------------------

Sets the running time of step 10 of simple PLC. The time unit is set by thousands place of F2-00.

F2-23	Setting of step 11	Range: 000 - 327	Factory default: 000
-------	--------------------	------------------	-------------------------

⌋ Unit's place: frequency setting

0: Multi-step frequency 11 (F1-13)

1 - 7: same as F2-01

┆ Decade: running direction (same as F2-01)

┆ Hundreds place: Accel/Decel time option (same as F2-01)

F2-24	Running time of step 11	Range: 0.0 - 6000.0s(min)	Factory default: 0.0s
-------	-------------------------	---------------------------	--------------------------

Sets the running time of step 11 of simple PLC. The time unit is set by thousands place of F2-00.

F2-25	Setting of step 12	Range: 000 - 327	Factory default: 000
-------	--------------------	------------------	-------------------------

┆ Unit's place: frequency setting

0: Multi-step frequency 12 (F1-14)

1 - 7: same as F2-01

┆ Decade: running direction (same as F2-01)

┆ Hundreds place: Accel/Decel time option (same as F2-01)

F2-26	Running time of step 12	Range: 0.0 - 6000.0s(min)	Factory default: 0.0s
-------	-------------------------	---------------------------	--------------------------

Sets the running time of step 12 of simple PLC. The time unit is set by thousands place of F2-00.

F2-27	Setting of step 13	Range: 000 - 327	Factory default: 000
-------	--------------------	------------------	-------------------------

┆ Unit's place: frequency setting

0: The time unit is set by thousands place of F2-00.

1 - 7: same as F2-01

┆ Decade: running direction (same as F2-01)

┆ Hundreds place: Accel/Decel time option (same as F2-01)

F2-28	Running time of step 13	Range: 0.0 - 6000.0s(min)	Factory default: 0.0s
-------	-------------------------	---------------------------	--------------------------

Sets the running time of segment 13 of simple PLC. The time unit is set by thousands place of F2-00.

F2-29	Setting of step 14	Range: 000 - 327	Factory default: 000
-------	--------------------	------------------	-------------------------

┆ Unit's place: frequency setting

0: Multi-step frequency 14 (F1-16)

1 - 7: same as F2-01

- ⌞ Decade: running direction (same as F2-01)
- ⌞ Hundreds place: Accel/Decel time option (same as F2-01)

F2-30	Running time of step 14	Range: 0.0 - 6000.0s(min)	Factory default: 0.0s
-------	-------------------------	---------------------------	--------------------------

Sets the running time of step 14 of simple PLC. The time unit is set by thousands place of F2-00.

F2-31	Setting of step 15	Range: 000 - 327	Factory default: 000
-------	--------------------	------------------	-------------------------

- ⌞ Unit's place: frequency setting
- 0: Multi-step frequency 15 (F1-17)
- 1 - 7: same as F2-01
- ⌞ Decade: running direction (same as F2-01)
- ⌞ Hundreds place: Accel/Decel time option (same as F2-01)

F2-32	Running time of step 15	Range: 0.0 - 6000.0s(min)	Factory default: 0.0s
-------	-------------------------	---------------------------	--------------------------

Sets the running time for step 15 of simple PLC. The time unit is set by thousand's place of F2-00.

& ATTENTION:

Digital input terminals "simple PLC paused", "simple PLC disabled" and "simple PLC stop memory clear" can be used during the running of simple PLC. See specification of digital input of Group C0 for details.

Group F3 Wobble Frequency and Fixed Length Count

Wobble frequency function is usually used in textile and chemical fiber industries where traverse motion is required. Wobble frequency control process is as follows: accelerate to the pre-frequency of wobble frequency function according to the current Accel time. Maintain this frequency for a period of time and run to center frequency of wobble frequency according to the current Accel/Decel time (i.e. the set frequency set by parameter group b0). Then run in a cyclic manner according to wobble frequency amplitude, hopping frequency, wobble frequency cycle time, and frequency ramp up time. When a stop command is given, the drive will ramp down to stop according to the set Decel time.

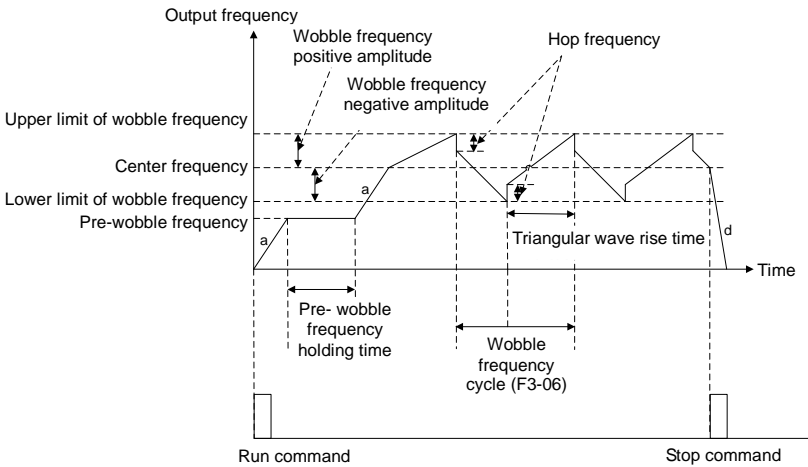

Fig. 6-55

a is the set Accel time (ramp up time), and d is the set Decel time (ramp down time).

F3-00	Wobble frequency function setting	Range: 0 - 1	Factory default: 0
-------	-----------------------------------	--------------	--------------------

0: Wobble frequency function disabled

1: Wobble frequency function enabled

F3-01	Wobble frequency running setting	Range: 0000 - 1111	Factory default: 0000
-------	----------------------------------	--------------------	-----------------------

U Unit's place: started method

0: Automatically

Run at pre-frequency of wobble frequency set by F3-02, maintain Pre-frequency holding time set by F3-03, and then automatically get into wobble frequency running.

1: Started by terminal

Digital input terminal "start wobble frequency" controls the running of wobble frequency.

When terminal inputs ON, the drive gets into wobble frequency running. When terminal inputs OFF, the drive exits wobble frequency and runs at pre-frequency of wobble frequency.

Under this mode, Pre-frequency holding time is enabled.

Under this mode, Pre-frequency holding time is enabled.

U Decade: amplitude control

0: Relative to center frequency

Amplitude = F3-04 x current command frequency.

1: Relative to maximum frequency

Amplitude = F3-04 x maximum frequency b0-08.

⊔ Hundreds place: wobble frequency memorized when stop

0: Memory enabled

The drive memorizes the current wobble frequency state when stop. When restarted, drive continues to run the wobble frequency with the memorized state at latest stop. Pre-frequency of wobble frequency F3-02 is enabled at restart.

1: Memory disabled

When the drive is started, it restarts wobble frequency running. Run at pre-frequency of wobble frequency F3-02, maintain this frequency for pre-frequency holding time F3-03, and then automatically gets into wobble frequency control.

⊔ Thousands place: wobble frequency memorized on power loss

0: Memory enabled

Automatically save the wobble frequency state on power loss. This function takes effect only under wobble frequency running.

1: Memory disabled

Drive clears wobble frequency status on power loss.

F3-02	Pre-wobble frequency	Range: 0.00Hz - 600.00Hz	Factory default: 0.00Hz
F3-03	Pre-wobble frequency holding time	Range: 0.0s - 3600.0s	Factory default: 0.0s

During the running of wobble frequency, F3-02 is the running frequency before the drive begins to run at wobble frequency, while F3-03 is the holding time of pre-wobble frequency. When F3-03 is set to 0, pre-frequency is disabled.

F3-04	Wobble frequency amplitude	Range: 0.0% - 50.0%	Factory default: 0.0%
-------	----------------------------	---------------------	--------------------------

The percentage is relative to center frequency or maximum frequency and determined by the decade of F3-01. Center frequency is the command frequency set by parameters of Group b0. Running frequency of wobble frequency is not only subject to this amplitude, but is also restricted by upper limit and lower limit of frequency.

F3-05	Hop frequency	Range: 0.0% - 50.0%	Factory default: 0.0%
-------	---------------	---------------------	--------------------------

Hop frequency = F3-05 × amplitude.

F3-06	Cycle of wobble frequency	Range: 0.1s - 999.9s	Factory default: 0.0s
-------	---------------------------	----------------------	--------------------------

The time of the completion of a complete process of wobble frequency

F3-07	Triangular wave ramp-up time	Range: 0.0% - 100.0%	Factory default: 0.0%
-------	------------------------------	----------------------	--------------------------

Sets the wobble frequency running time of ramp-up segment.

Triangular wave ramp up time = F3-07 × F3-06

Wobble frequency ramp-down time = F3-06 - triangular wave ramp-up time

& ATTENTION:

- Ø The current wobble frequency status can be cleared by digital input terminal "clear wobble frequency status" in stop status.
- Ø If the output frequency exceeds upper limit frequency or lower limit frequency during the running at wobble frequency, digital output terminal "wobble frequency attains to upper or lower limit frequency" outputs ON signal

Parameters F3-08 - F3-11 are for fixed-length stop.

F3-08	Length unit	Range: 0 - 1	Factory default: 0
-------	-------------	--------------	--------------------

0: m

1: 10m

F3-09	Length setting	Range: 0 - 65535	Factory default: 1000
-------	----------------	------------------	--------------------------

Sets the length value of fixed-length stop. When set to 0, fixed-length stop function is enabled, but the actual length is still calculated. When it is detected the actual length attains this set value, digital output terminal "length attained" will output ON signal and perform the command set by F3-11.

F3-10	Number of pulses per meter	Range: 0.1 - 6553.5	Factory default: 100.0
-------	----------------------------	---------------------	---------------------------

Input pulse is received via digital input terminal "length count"; the number of pulses per meter is set here.

F3-11	Command when the length attained	Range: 0 - 1	Factory default: 0
-------	----------------------------------	--------------	--------------------

0: Not stop 1: Stop

This parameter sets the action of the drive when actual length attains the length set by F3-09.

Actual length can be cleared through digital input terminal "length clear".

& ATTENTION:

- ∅ When actual length is detected to attain the set length, digital output terminal "length attained" outputs ON signal no matter the drive is set to stop or not stop.
- ∅ Actual length is saved at power loss and can be read in both stop and running.

F3-12	Set count value	Range: 1 - 65535	Factory default: 1000
F3-13	Designated count value	Range: 1 - 65535	Factory default: 1000

The two parameters are used with digital input terminal "count input" and digital output terminals "set count value attained" and "designated count value attained".

Input pulse through digital input terminal "count input". When the number of pulses attain the value set by F3-12, the terminal outputs ON. With the completion of the value of F3-12, the terminal "designated count value attained" outputs OFF.

When the number of input pulses attains the designated count value of F3-13, terminal "designated count value attained" will output ON. Upon the completion of set count value of F3-12, terminal "designated count value attained" outputs OFF.

For example: F3-12= 10, F3-13= 7. Fig. 6-56:

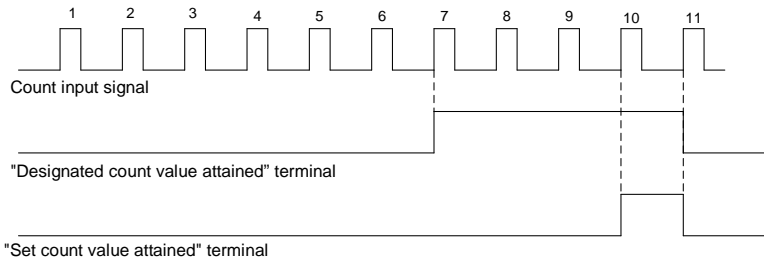

Fig. 6-56

& ATTENTION:

- ∅ Actual count value can be cleared through digital input terminal "count clear".
- ∅ Actual count value is saved at power loss.

Group H Communication Parameters

Group H0 MODBUS Communication Parameters

Support universal Modbus protocol. Please refer to appendix for detailed description of communication protocol.

H0-00	RS-485 port terminal resistance	Range: 0 - 1	Factory default: 0
-------	---------------------------------	--------------	--------------------

0: 100Ω terminal resistance not connected

1: 100Ω terminal resistance connected

H0-01	RS-485 port communication configuration	Range: 000 - 155	Factory default: 001
-------	---	------------------	----------------------

U Unit's place: baud rate

0: 4800bps

1: 9600bps

2: 19200bps

3: 38400bps

4: 57600bps

5: 115200bps

U Decade: data format

0: 1-8-2-N format, RTU

1: 1-8-1-E format, RTU

2: 1-8-1-O format, RTU

3: 1-7-2-N format, ASCII

4: 1-7-1-E format, ASCII

5: 1-7-1-O format, ASCII

U Hundreds place: connection type

0: Direct cable connection (232/485)

1: MODEM (232) (reserved)

H0-02	RS-485 communication address	Range: 0 - 247	Factory default: 5
-------	------------------------------	----------------	--------------------

Sets this drive address. 0 is broadcast address, while available addresses are 1 - 247.

H0-03	Time out detection	Range: 0.0s - 1000.0s	Factory default: 0.0s
-------	--------------------	-----------------------	-----------------------

This parameter sets communication error detection time. When it's set to 0, no communication error will be reported.

H0-04	Communication time delay	Range: 0ms - 1000ms	Factory default: 0ms
-------	--------------------------	---------------------	----------------------

Sets response time delay of this drive to the master.

H0-05	Master/Slave option	Range: 0 - 2	Factory default: 0
-------	---------------------	--------------	--------------------

0: PC controls the drive

PC as master controls the drive. This supports all communication protocols.

1: As master

This drive as master sends current running frequency data through RS-485 port. Data cannot be received but sent, and the sending data is only running frequency.

2: As slave

Put the received data into b0-02 (digital setting of master frequency) or F0-01 (PID digital setting) through communication. b0-02/F0-01 is selected by parameter H0-06. Other communication data addresses are not supported. As slave, this drive can only receive the data.

H0-06	Parameter store address	Range: 0 - 1	Factory default: 0
-------	-------------------------	--------------	--------------------

0: b0-02

1: F0-01

Enabled when H0-05 is set to 2. This parameter sets the store address of received data when it works as slave.

H0-07	Proportional factor of received frequency	Range: 0.0% - 100.0%	Factory default: 100.0%
-------	---	----------------------	-------------------------

Enabled when H0-05 is set to 2. Received data is multiplied by H0-07 and then put the result into the address set by H0-06. This parameter setting is very useful when a master drive control a number of slave drives and needs to allocate the frequency.

Group L Keys and Display of Keypad

Group L0 Keys of Keypad

L0-00	MF key setting	Range: 0 - 6	Factory default: 0
-------	----------------	--------------	--------------------

0: No function

1: Forward jog

2: Reverse jog

3: Forward/reverse switchover

4: Emergency stop 1 (set Decel time on b2-09)

5: Emergency stop 2 (coast to stop)

6: Run command sources shifted (keypad/terminal/communication)

L0-01	Keys locked option	Range: 0 - 4	Factory default: 0
-------	--------------------	--------------	--------------------

0: Not locked

1: Full locked

2: Keys locked other than RUN, STOP/RESET

3: Keys locked other than STOP/RESET

4: Keys locked other than >>

Please refer to Chapter 4 for locking operation of keys.

L0-02	Function of STOP key	Range: 0 - 1	Factory default: 0
-------	----------------------	--------------	--------------------

0: STOP key valid only when under keypad control

1: STOP key valid under any run command source

L0-03	Frequency adjustment through keys /	Range: 000 - 111	Factory default: 000
-------	-------------------------------------	------------------	----------------------

□ Unit's place: option on stop

0: Clear on stop

Keys \wedge / \vee frequency adjustment step size is cleared at the stop of drive.

1: Holding on stop

Keys \wedge / \vee frequency adjustment step size is held at the stop of drive.

□ Decade: option on power loss

0: Clear on power loss

Keys \wedge / \vee frequency adjustment step size is cleared at power loss.

1: Holding on power loss

Keys \wedge / \vee frequency adjustment step size is saved on power loss.

□ Hundreds place: integrating option

0: Integrating disabled

Adjustment step size is kept constant when frequency is adjusted by keys \wedge / \vee , and the adjustment will be performed always with the step size set by L0-04.

1: Integrating enabled

When frequency is adjusted by keys \wedge / \vee , the initial step size is the set value of L0-04. With the press increase of \wedge / \vee , adjustment step size shows cumulative integrating effect and will increase gradually.

L0-04	Step size of frequency adjustment through keys /	Range: 0.00Hz/s - 10.00Hz/s	Factory default: 0.03 Hz/s
-------	--	-----------------------------	----------------------------

When frequency command pattern is "digital setting + keypad \wedge / \vee adjustment", progressive increase and decrease of command frequency is realized through \wedge / \vee on keypad. This parameter is used to set the step size of frequency adjustment through \wedge / \vee . The step size is defined as frequency variation per second, and the smallest step size is 0.01 Hz/s.

Group L1 LED Display Setting

L1-00	LED displayed parameters setting 1 on running status	Range: 0000 - 37FF	Factory default: 000F
-------	--	--------------------	-----------------------

Sets LED displayed parameters on running status. When a number of parameters are selected to be

displayed, skim-through could be performed using key >> on keypad.

0: Display disabled

1: Display enabled

u Unit's place

BIT0: Running frequency (Hz)

BIT1: Command frequency (Hz)

BIT2: Bus voltage (V)

BIT3: Output current (A)

u Decade

BIT0: Output torque (%)

BIT1: Output power (kW)

BIT2: Output voltage (V)

BIT3: Motor speed (r/min)

u Hundreds place

BIT0: AI1 (V)

BIT1: AI2 (V)

BIT2: EAI (V)

BIT3: Reserved

u Thousands place

BIT0: DI

BIT1: External count value

BIT2: Reserved

BIT3: Reserved

& ATTENTION:

When this parameter is set to 0000, running frequency (Hz) is displayed as default.

Example:

To display running frequency, output current, motor speed and AI1 sampled value, L1-00 should be: 0000 0001 1000 1001, i.e. set L1-00 to 0189.

L1-01	LED displayed parameter setting 2 on running status	Range: 0000 - 00FF	Factory default: 0000
-------	---	--------------------	--------------------------

0: Display disabled

1: Display enabled

u Unit's place

BIT0: Running linear speed (m/s)

BIT1: Set linear speed (m/s)

BIT2: Input terminal status

BIT3: Output terminal status

u Decade

- BIT0: PID setting (%)
- BIT1: PID feedback (%)
- BIT2: Set length (m)
- BIT3: Actual length (m)
- ⌞ Hundreds place: Reserved
- ⌞ Thousands place: Reserved

L1-02	LED displayed setting on stop status	Range: 0000 - FF7F	Factory default: 0003
-------	--------------------------------------	--------------------	-----------------------

Sets LED displayed parameters on stop status. When a number of parameters are selected, skim-through could be realized via key >> on keypad.

- 0: Displayed disabled
- 1: Displayed enabled
- ⌞ Unit's place
- BIT0: Command frequency (Hz)
- BIT1: Bus voltage (V)
- BIT2: Input terminal status
- BIT3: Output terminal status
- ⌞ Decade
- BIT0: AI1 (V)
- BIT1: AI2 (V)
- BIT2: EAI (V)
- BIT3: Reserved
- ⌞ Hundreds place
- BIT0: PID setting (%)
- BIT1: PID feedback (%)
- BIT2: Set length (m)
- BIT3: Actual length (m)
- ⌞ Thousands place
- BIT0: Running linear speed (m/s)
- BIT1: Set linear speed (m/s)
- BIT2: External count value
- BIT3: DI

Note: when this function code is set to 0000, the set frequency would be displayed as default (Hz).

Example:

To display command frequency, bus voltage, AI1 sampled value, set length and external count value, L1-02 should be: 0100 0100 0001 0011, i.e. set L1-02 to 4413.

L1-03	Linear speed coeff	Range: 0.1% - 999.9%	Factory default: 100.0%
-------	--------------------	----------------------	-------------------------

This coefficient is used for calculation of linear speed.

Running linear speed = motor running speed x L1-03

Set linear speed = motor setting speed x L1-03

Both running linear speed and set linear speed can be viewed during running and stop.

Group U Monitoring

Group U0 Status Monitoring

All parameters of Group U0 are for display purpose only and can't be set.

U0-00	Running frequency	Range: 0.00Hz - 600.00Hz	Factory default: 0.00Hz
U0-01	Set frequency	Range: 0.00Hz - 600.00Hz	Factory default: 0.00Hz
U0-02	Bus voltage	Range: 0V - 65535V	Factory default: 0V
U0-03	Output voltage	Range: 0V - 65535V	Factory default: 0V
U0-04	Output current	Range: 0.0A - 6553.5A	Factory default: 0.0A
U0-05	Output torque	Range: 0.0% - 300.0%	Factory default: 0.0%
U0-06	Output power	Range: 0.0% - 300.0%	Factory default: 0.0%
U0-07	Master frequency command source	Range: 0 - 9	Factory default: 0
U0-08	Auxiliary frequency command source	Range: 0 - 10	Factory default: 0
U0-09	Master frequency setting	Range: 0.00Hz - 600.00Hz	Factory default: 0.00Hz
U0-10	Auxiliary frequency setting	Range: 0.00Hz - 600.00Hz	Factory default: 0.00Hz
U0-11	Drive status	Range: 0 - 22	Factory default: 00

U Unit's place: Running status

0: Accelerating

- 1: Decelerating
- 2: Constant speed running
- u Decade: drive status
- 0: Stop
- 1: Running status
- 2: Motor parameters are being identified

U0-12	AI1 input voltage	Range: 0.00V - 10.00V	Factory default: 0.00V
U0-13	AI2 input voltage	Range: -10.00V - 10.00V	Factory default: 0.00V
U0-14	EAI input voltage	Range: 0.00V - 10.00V	Factory default: 0.00V
U0-15	AO1 output	Range: 0.0% - 100.0%	Factory default: 0.0%
U0-16	EAO output	Range: 0.0% - 100.0%	Factory default: 0.0%
U0-17	X6/DI HF pulse frequency	Range: 0.0kHz - 50.0kHz	Factory default: 0.0kHz

U0-18	Status of digital input terminal	Range: 00 - 7F	Factory default: 00
-------	----------------------------------	----------------	---------------------

Digital input terminals that correspond to the bits of U0-18 are as shown in Table 6-19:

Table 6-19

Decade			Unit's place			
bit6	bit5	bit4	bit3	bit2	bit1	bit0
EX	X6	X5	X4	X3	X2	X1

0 means terminal input status is OFF, while 1 means terminal input status is ON.

For example:

If 23 (i.e. 0010 0011) is displayed at U0-18, it means the input status of terminals X1, X2 and X6 is ON and that of the other terminals is OFF.

If 05 (i.e. 0000 0101) is displayed at U0-18, it means the input status of terminals X1 and X3 is ON while that of the other terminals is OFF.

U0-19	Status of digital output terminal	Range: 0 - 7	Factory default: 0
-------	-----------------------------------	--------------	--------------------

Corresponding relationship between digital output terminals and the bits of U0-19 is shown in Table 6-20:

Table 6-20

bit3	bit2	bit1	bit0
Expansion board relay	Control board relay	Y2	Y1

0 means terminal output status is OFF, while 1 means terminal output status is ON.

For example:

If 6 (i.e. 0110) is displayed at U0-19, it means the output status of terminals Y2 and control board relay is ON while that of the other terminals is OFF.

U0-20	PID set	Range: 0.0% - 100.0%	Factory default: 0.0%
U0-21	PID feedback	Range: 0.0% - 100.0%	Factory default: 0.0%
U0-22	PID input offset	Range: -100.0% to 100.0%	Factory default: 0.0%
U0-23	PLC step	Range: 1 - 16	Factory default: 0
U0-24	V/f separated target voltage	Range: 0.0% - 100.0%	Factory default: 0.0%
U0-25	V/f separated actual output voltage	Range: 0.0% - 100.0%	Factory default: 0.0%
U0-30	Cumulative power-up time	Range: 0h - 65535h	Factory default: 0h
U0-31	Cumulative running time	Range: 0h - 65535h	Factory default: 0h
U0-32	Rectifier bridge temperature	Range: -40.0°C to 100.0°C	Factory default: 0.0
U0-33	Inverter bridge temperature	Range: -40.0°C to 100.0°C	Factory default: 0.0
U0-34	U0-34	Range: 0 - 6	Factory default: 0

When the drive reports fault "FAL", the fault source can be known by U0-34.

- 0: No fault source
- 1: FAL itself
- 2: 5V fault
- 3: Ground fault
- 4: OC fault
- 5: OU fault
- 6: Other sources

U0-35	Terminal count value	Range: 0 - 65535	Factory default: 0
U0-36	Run command record at LoU	Range: 0 - 1	Factory default: 0
U0-37	Fault code record at LoU	Range: 0 - 100	Factory default: 0
U0-38	Reserved	Reserved	Reserved
U0-39	Current detection fault source	Range: 0 - 3	Factory default: 0

- 0: No fault source
- 1: IU
- 2: IV
- 3: IW

U0-40	Higher-place numeric of actual length	Range: 0 - 65	Factory default: 0
U0-41	Lower-place numeric of actual length	Range: 0 - 65535	Factory default: 0
U0-42	Higher-place numeric of keypad / stored value	Range: -1 to 1	Factory default: 0
U0-43	Lower-place numeric of keypad / stored value	Range: 0.00 - 655.35Hz	Factory default: 0.00Hz
U0-44	Higher-place numeric of terminal UP/DOWN stored value	Range: -1 to 1	Factory default: 0
U0-45	Lower-place numeric of terminal UP/DOWN stored value	Range: 0.00 - 655.35 Hz	Factory default: 0.00Hz
U0-52	Center FREQ of wobble FREQ	Range: 0 - 600.00 Hz	Factory default: 0.00 Hz

Group U1 Fault Record

U1-00	Code of the latest fault	Range: 0 - 45	Factory default: 0
U1-01	Running frequency when the latest fault occurred	Range: 0.00Hz - 600.00Hz	Factory default: 0.00Hz
U1-02	Output current when the latest fault occurred	Range: 0.0A - 6553.5A	Factory default: 0.0A
U1-03	Bus voltage when the latest fault occurred	Range: 0V - 10000V	Factory default: 0V
U1-04	Rectifier bridge temperature when the latest fault occurred	Range: -40.0°C to 100.0°C	Factory default: 0.0
U1-05	Inverter bridge temperature when the latest fault occurred	Range: -40.0°C to 100.0°C	Factory default: 0.0
U1-06	Status of input terminal when the latest fault occurred	Range: 0000 - FFFF	Factory default: 0000
U1-07	Status of output terminal when the latest fault occurred	Range: 0000 - FFFF	Factory default: 0000
U1-08	Cumulative running time when the latest fault occurred	Range: 0h - 65535h	Factory default: 0h

Check the information of the latest fault. See Chapter 7 for details of fault codes.

U1-09	Code of previous fault	Range: 0 - 45	Factory default: 0
U1-10	Running frequency when previous fault occurred	Range: 0.00Hz - 600.00Hz	Factory default: 0.00Hz
U1-11	Output current when previous fault occurred	Range: 0.0A - 6553.5A	Factory default: 0.0A
U1-12	Bus voltage when previous fault occurred	Range: 0V - 10000V	Factory default: 0V
U1-13	Rectifier bridge temperature when previous fault occurred	Range: -40.0°C to 100.0°C	Factory default: 0.0
U1-14	Inverter bridge temperature when previous fault occurred	Range: -40.0 to 100.0	Factory default: 0.0
U1-15	Status of input terminal when previous fault occurred	Range: 0000 - FFFF	Factory default: 0000

U1-16	Status of output terminal when previous fault occurred	Range: 0000 - FFFF	Factory default: 0000
U1-17	Cumulative running time when previous fault occurred	Range: 0h - 65535h	Factory default: 0h

Check the information of previous fault. See Chapter 7 for details of fault codes.

U1-18	Before-previous fault code	Range: 0 - 45	Factory default: 0
U1-19	Running frequency when before-previous fault occurred	Range: 0.00Hz - 600.00Hz	Factory default: 0.00Hz
U1-20	Output current when before-previous fault occurred	Range: 0.0A - 6553.5A	Factory default: 0.0A
U1-21	Bus voltage when before-previous fault occurred	Range: 0V - 10000V	Factory default: 0V
U1-22	Rectifier bridge temperature when before-previous fault occurred	Range: -40.0°C to 100.0°C	Factory default: 0.0
U1-23	Inverter bridge temperature when before-previous fault occurred	Range: -40.0°C to 100.0°C	Factory default: 0.0
U1-24	Status of input terminal when before-previous fault occurred	Range: 0000 - FFFF	Factory default: 0000
U1-25	Status of output terminal when before-previous fault occurred	Range: 0000 - FFFF	Factory default: 0000
U1-26	Cumulative running time when before-previous fault occurred	Range: 0h - 65535h	Factory default: 0h

Check the information of before-previous fault (the fault sequence: before-previous fault, previous fault, latest fault). See Chapter 7 for details of fault codes

Chapter 7 Troubleshooting

7.1 Fault Causes and Troubleshooting

Once drive fault occurs, please identify the causes of fault carefully and make a detailed record of fault symptom. To seek services, please contact the dealer.

Parameters U1-00, U1-09 and U1-18 are used to view the records of the latest, the previous and before-previous faults. Faults are recorded with numeric codes (0 - 45), while the fault information that corresponds to each numeric fault code is specified in the table below.

Table of Fault Codes

Fault code	Fault Display	Fault description	Causes	Solutions
1	oC1	Accel overcurrent	Torque boost is too big under V/f control	Reduce torque boost value
			Starting frequency is too high	Drop starting frequency
			Accel time is too short	Prolong the Accel time
			Motor parameters are improperly set	Set the parameters correctly according to motor nameplate
			Output short circuit (phase-to-phase short circuit or output ground short circuit)	Check motor connection and output ground impedance
			Overload is too heavy	Reduce the load
			Inappropriate V/f curve under V/f control	Set V/f curve correctly
			Restart the rotating motor	Reduce current limited value or start through speed search
2	oC2	Constant-speed overcurrent	Output short circuit (phase-to-phase short circuit or output ground short circuit)	Check motor connection and output ground impedance
			Overload is too heavy	Reduce the load
			Power rating of the drive is relatively small	Select appropriate drive power rating

Fault code	Fault Display	Fault description	Causes	Solutions
			Input voltage is too low	Check power grid voltage
3	oC3	Decel overcurrent	Output short circuit (phase-to-phase short circuit or output ground short circuit)	Check motor connection and output ground impedance
			Load inertia is too big	Use dynamic brake
			Decel time is too short	Prolong the Decel time
			Input voltage is too low	Check power grid voltage
4	ov1	Accel overvoltage	Load inertia is too big	Use dynamic brake
			Abnormal input voltage	Check power grid voltage
			Output short circuit (phase-to-phase short circuit or output ground short circuit)	Check motor connection and output ground impedance
5	ov2	Constant-speed overvoltage	Load variation is too big	Check the load
			Abnormal input voltage	Check power grid voltage
			Output short circuit (phase-to-phase short circuit or output ground short circuit)	Check motor connection and output ground impedance
			Improper parameter setting of regulator under SVC control	Properly set regulator parameters
6	ov3	Decel overvoltage	Load inertia is too big	Use dynamic braking
			Abnormal input voltage	Check power grid voltage
			Output short circuit (phase-to-phase short circuit or output ground short circuit)	Check motor connection and output ground impedance
			Improper parameter setting of regulator under SVC control	Properly set regulator parameters

Fault code	Fault Display	Fault description	Causes	Solutions
			Decel time is too short	Prolong the Decel time
7	FAL	Module protection	Output short circuit (phase-to-phase short circuit or output ground short circuit)	Check motor connection and output ground impedance
			Fan damaged or air duct blocked	Clear the air duct or replace the fan
			Direct connection of inverter module	Seek services
			Switching power supply damaged	Seek services
			Control board abnormal	Seek services
			Ambient temperature is too high	Reduce ambient temperature
			Loose connection of control board	Pull out and reinsert the cables of control board
			Overvoltage or overcurrent	Handle it with the solutions of overvoltage or overcurrent
8	tUN	Parameter identification failed	Bad motor connection	Check motor connection
			Identification during rotation of the motor	Identification in stationary status of the motor
			Bias between motor parameters and their setting is too big	Set the parameters correctly according to motor nameplate
9	oL1	Drive overloaded	Torque boost is too big under V/f control	Reduce torque boost value
			Starting frequency is too high	Drop starting frequency
			Accel/Decel time is too short	Prolong the Accel/Decel time
			Motor parameters are improperly set	Set the parameters correctly according to motor nameplate
			Output short circuit (phase-to-phase short	Check motor connection and output ground

Fault code	Fault Display	Fault description	Causes	Solutions
			circuit and output ground short circuit)	impedance
			Load is too heavy	Reduce the load
			Inappropriate V/f curve under V/f control	Set V/f curve correctly
			Restart the rotating motor	Reduce current limited value or start through speed search
10	oL2	Motor overloaded	Torque boost is too big under V/f control	Reduce torque boost value
			Inappropriate V/f curve under V/f control	Set V/f curve correctly
			Motor parameters are improperly set	Set the parameters correctly according to motor nameplate
			Improper setting of motor overloaded protection time	Properly set the motor overloaded protection time
			Motor stalled or sharp variation of load	Identify the causes of motor stalling or check the load condition
			Long-term running of ordinary motor at low speed with heavy load	Select variable frequency motor
11	CtC	Current detection abnormal	Abnormal connection of control board	Seek services
			Switching power supply damaged	Seek services
			Hall device damaged	Seek services
			Output ground leakage current is too big	Seek services
12	GdP	Output ground short-circuit protection	Output connection ground short circuit	Check motor connection and output ground impedance
			Motor insulation abnormal	Check the motor
			Inverter module	Seek services

Fault code	Fault Display	Fault description	Causes	Solutions
			abnormal	
			Output ground leakage current is too big	Seek services
13	ISF	Input power supply abnormal	Serious voltage imbalance among three phases of power supply	Check power grid voltage
			Abnormal bus capacitance	Seek services
			Abnormal input wiring of power supply	Check power supply input wiring
14	oPL	Output phase loss	Motor cable connection abnormal	Check motor connection
			Imbalance among motor three phases	Check or replace the motor
			Incorrect setting of vector control parameters	Correctly set vector control parameters
15	oL3	Inverter module overload protection	Overcurrent	Handle it with the methods for overcurrent
			Input power supply abnormal	Check input power grid voltage
			Motor output abnormal	Check the motor or motor connection
			Inverter module abnormal	Seek services
16	oH1	Heat sink thermal protection	Ambient temperature is too high	Drop ambient temperature
			Fan damaged	Replace the fan
			Air duct blocked	Clear air duct
			Temperature sensor abnormal	Seek services
			Inverter module abnormal	Seek services
17	oH2	Motor (PTC) thermal protection	Ambient temperature is too high	Drop ambient temperature
			Improper setting of motor thermal protection point	Correctly set motor thermal protection point

Fault code	Fault Display	Fault description	Causes	Solutions
			Detection circuit damaged	Seek services
18	oH3	Module temperature detection undisconnected	Module detection circuit damaged	Seek services
			Thermistor damaged	Seek services
			Ambient temperature is too low	Raise ambient temperature
20	EC1	Expansion board connection abnormal	Expansion board abnormal	Seek services
			Loose or poor expansion board connection	Pull out and reinsert
			Control board abnormal	Seek services
22	dLC	Drive line connection abnormal	Drive board abnormal	Seek services
			Loose or poor drive line connection	Pull out and re-insert after overall power-down
			Control board abnormal	Seek services
23	TEr	Function conflict of analogue terminals	Analogue input terminals are set to the same function	Do not set analogue inputs to the same function
24	PEr	External equipment error	External fault terminal is enabled	Check the status of external fault terminal
			Stall condition lasts too long	Check if the load is abnormal
26	to2	Consecutive running time attained	"Consecutive running time attained" enabled	See specification of Group E0
27	to3	Cumulative running time attained	"Cumulative running time attained" enabled	See specification of Group E0
28	SUE	Power supply abnormal at running	Fluctuation of grid voltage is out of range	Check input power grid voltage
29	EPr	EEPROM read/write fault	Parameter read/write abnormal on control board	Seek services
30	CCL	Contactors	Contactors damaged	Seek services

Fault code	Fault Display	Fault description	Causes	Solutions
		suction fault	Abnormal contactor feedback circuit on control board	Seek services
			Buffer resistance damaged	Seek services
			Power grid input voltage abnormal	Check input power grid voltage
			Switching power supply abnormal	Seek services
31	TrC	Port communication abnormal	Improper setting of baud rate	Set properly
			Communication port disconnection	Reconnect
			Upper computer/device does not work	Make upper computer/device work
			Drive communication parameter error	Set properly
32	PdC	Keypad communication abnormal	Keypad disconnection	Re-connect
			Severe EMI	Check peripheral equipment or seek services
33	CPy	Parameter copy fault	Parameter uploading or downloading abnormal	Seek services
			No parameters on keypad	Seek services
35	SFt	Software version compatibility failure	Version of keypad is not consistent with that of control board	Seek services
36	CPU	CPU interference fault	Severe EMI	Check peripheral equipment or seek services
			Control board abnormal	Seek services
37	oCr	Benchmark protection	Switching power supply damaged	Seek services
			Control board damaged	Seek services
38	SP1	5V power supply	Switching power supply	Seek services

Fault code	Fault Display	Fault description	Causes	Solutions
		out-of-limit	damaged	
			Control board damaged	Seek services
39	SP2	10V power supply out-of-limit	Switching power supply damaged	Seek services
			Control board damaged	Seek services
40	AIP	AI input out-of-limit	Control board damaged	Seek services
			AI input is too high or low	Set AI input within correct range
41	LoU	Undervoltage protection	Input voltage abnormal	Check input power grid voltage
			Switching power supply abnormal	Seek services
45	Plo	PID detection out-of-limit	PID feedback channel abnormal	Check the feedback channel
			Inappropriate setting of PID parameters	Set properly

& ATTENTION:

When a fault occurs, please identify the causes and seek solutions according the guidance in the table. If the fault fails to be solved, do not apply power to the drive again. Contact the supplier for service in time

Chapter 8 Maintenance

Ambient temperature, humidity, salt mist, dust, vibration, aging and wear of internal components may result in drive faults. Routine maintenance shall be performed during the use and storage.

& ATTENTION:

Please make sure the power supply of the drive has been cut off, and DC bus voltage has discharged to 0V before the maintenance.

8.1 Routine Inspection

Please use the drive in the environment recommended by this manual, and perform routine inspection in accordance with the table below.

Inspection items	Inspection aspects	Inspection methods	Criteria
Operating environment	Temperature	Thermometer	-10°C to 50°C
	Humidity	Hygrometer	5% - 95%, condensation not allowed
	Dust, oil stains, moisture and water-drop	Visual inspection	No filthy mud, oil stains and water drop
	Vibration	Observation	Smooth running. No abnormal vibration
	Gas	Smell, visual inspection	No peculiar smell and abnormal smoke
Drive	Noise	Listen	No abnormal noise
	Gas	Smell, visual inspection	No peculiar smell and abnormal smoke
	Appearance	Visual inspection	No defect and deformation
	Heat dissipation and temperature rise	Visual inspection	No dust and/or fiber particles in air duct, normal working of fans, normal air speed and volume, no abnormal temperature rise

Inspection items	Inspection aspects	Inspection methods	Criteria
Motor	Thermal status	Smell	No abnormal heating and scorching smell
	Noise	Listen	No abnormal noise
	Vibration	Observe, listen	No abnormal vibration and sound
Running status parameters	Power supply input current	Ammeter	In the range of requirement
	Power supply input voltage	Voltmeter	In the range of requirement
	Drive output current	Ammeter	In the range of requirement
	Drive output voltage	Voltmeter	In the range of requirement
	Temperature	Thermometer	The difference between U0-33 displayed temperature and ambient temperature does not exceed 40

8.2 Regular Maintenance

Users should perform regular inspection of the drive every 3 - 6 months, so as to eliminate the potential faults.

& ATTENTION:

- Ø Please make sure power supply of the drive has been cut off, and DC bus voltage has been discharged to 0V prior to maintenance.
- Ø Never leave screws, gaskets, conductors, tools and other metal articles inside the drive. Failure to comply may result in equipment damage.
- Ø Never modify the interior components of the drive in any condition. Failure to comply may result in equipment damage.

Inspection items	Measures
Check if control terminal screws are loose	Tighten
Check if main circuit terminal screws are loose	Tighten
Check if ground terminal screws are loose	Tighten
Check if copper bar screws are loose	Tighten
Check if drive mounting screws are loose	Tighten

Inspection items	Measures
Check if there are damage on power cables and control cables	Replace the damaged cables
Check if there is dust on circuit board	Clear it up
Check if air duct is blocked	Clear it up
Check if drive insulation is damaged	Test the ground terminal with 500V megameter after all input and output terminals are short-circuited via conductors. Ground test on individual terminals is strictly prohibited since this may cause damage to inverter.
Check if motor insulation is damaged	Remove input terminals U/V/W of motor from drive and test the motor alone with 500V megameter. Failure to comply may result in drive damage.
Check if the storage period of the drive is over two years	Carry out power-on test, during which, the voltage should be boosted to rated value gradually using a voltage regulator; be sure to run at no load for more than 5 hours.

8.3 Replacement of Vulnerable Parts

Vulnerable parts of drive include cooling fan, electrolytic capacitor, relay or contactor etc. The service lives of these parts are subject to environment and working conditions. To maintain a favorable operating environment is conducive to improving the service life of parts and components; routine inspection and maintenance also contributes to effective improvement of parts' service life. To prolong the service life of entire drive, the cooling fan, electrolytic capacitor, relay or contactor and other vulnerable parts should be subjected to routine inspection according to the table below. Please replace the abnormal parts (if any) in time.

Vulnerable parts	Service life	Cause of damage	Criteria
Fan	30,000 - 40,000h	Wear of bearing and aging of blade	Check if fan blades have cracks Check if there is abnormal vibration and noise on working
Electrolytic capacitor	40,000 - 50,000h	Excessively high ambient temperature and excessively low air pressure result in electrolyte volatilization; aging of electrolyte capacitor	Check if there is liquid leakage Check if safety valve projects Check if capacitance value is out of allowable range Check if insulation resistance is abnormal
Relay/contact actor	50,000 - 100,000 times	Corrosion and dust impairs the contacting effect of contact; excessively frequent contact action	Open/close failure False alarm of CCL fault

8.4 Storage

Storage environment should meet the requirements as set forth in the table below.

Items	Requirements	Recommended storage method and environment
Storage temperature	-40 to +70°C	In case of long-term storage, areas with an ambient temperature of less than 30°C are recommended Avoid the storage in areas where temperature shock may result in condensation and freezing
Storage humidity	5 - 95%	Product could be sealed with plastic film and dessicant
Storage environment	A space with low vibration and low content of salt where there is no direct exposure to sunlight, dust, no corrosive or flammable gas, oil stain, vapor and water drop	Product could be sealed with plastic film and dessicant

& ATTENTION:

Since long-term storage may lead to the deterioration of electrolytic capacitor, the inverter must be powered on once in case storage period exceeds 2 years. During the power-on, input voltage must be boosted to rated value gradually using a voltage regulator, and be sure to have the inverter operate at no load for more than 5 hours.

Chapter 9. Options

Available options

Part number	Option name	Function
01-5706-00	EPC-CM1	RS232 communication board Support expanded RS232 communication.
01-5710-00	EPC-VD1	Voltage measurement board Support the detection of input voltage, output voltage, and bus voltage.
01-5711-00	EPC-VD2	Flying start board For flying start (speed search) function, and b1-05 should be set to 3. With this card, flying start will be accurate and smooth; While without this card (b1-05=2), flying start may be failed, or not accurate/smooth.
01-5712-00	EPC-TM1	Extended IO board Support one analogue input, one digital input, one analogue output, and one relay output.
01-5713-00	EPC-RT1	Real-time Support real-time clock input, one analogue input, and one relay output.
01-5709-00	EPC-IM1	Analogue input board 0-1 A/0-24V Support two current/voltage analogue inputs. Current input: 0A-1A, Voltage input: 0V-24V(for injection molding machine application).
01-5714-00	CBL-EX1-	Cable for keypad (2m)
01-5715-00	CBL-EX2	Cable for keypad (3m)
01-5716-00	CBL-EX3	Cable for keypad (5m)

Appendix Communication Protocol

1. Networking Mode

The drives have two networking modes, single master/multiple slaves networking and single master/single slave networking.

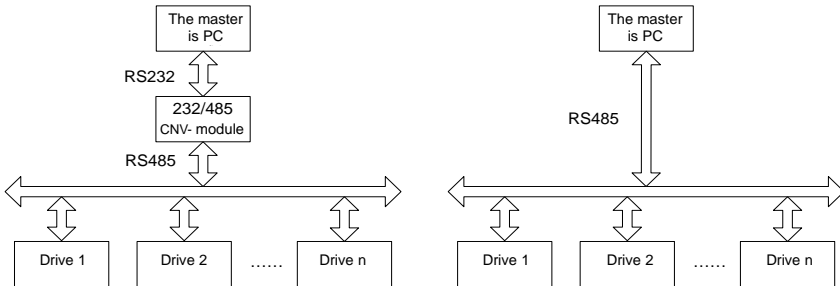

Single master/multiple slaves networking diagram

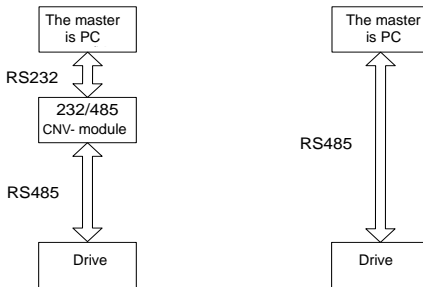

Single master/single slave networking diagram

2. Interface Mode

RS485 or RS232 interface: asynchronous, semiduplex.

Default data format: 8-N-2 (8 data bits, no check, two stop bits), 9600 bps. See parameters of Group H0 for parameter setting.

3. Communication Mode

- 1) Drive is used as a slave for master-slave point-to-point communication. When master

- sends commands using broadcast address, the slave does not respond;
- 2) Native address, baud rate and data format of inverter are set through slave operating panel or serial communication;
- 3) Slave reports the current fault information in the latest response frame for master polling;
- 4) Drive employs RS-485 interface mode.

4. Protocol Format

Modbus protocol supports both RTU and ASCII mode.

RTU data frame format is shown as the figure below:

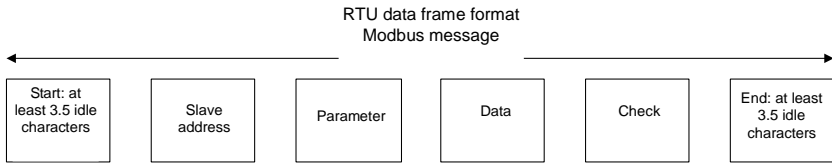

RTU:

In RTU mode, idle time between frames can be set through function code or comply with Modbus internal convention, for which the minimum interframe idle is as follows:

- 1) Frame header and end define the frame by making bus idle time equal to or longer than 3.5-byte time;
- 2) After the start of frame, the clearance between characters must be less than 1.5-character communication time, or the newly received characters will be treated as the header of the new frame;
- 3) Data check employs CRC-16 and the whole information participates in the check; the high and low bytes of check sum shall be sent after exchange. Please refer to examples at the end of protocol for details of CRC check;
- 4) The bus idle time of at least 3.5 characters (or set minimum bus idle time) shall be maintained between frames and needs not to accumulate the starting and ending idle time.

The data frame of which the request frame is "reading parameter 002 of #1 machine" is as below:

Appendix Table 1

Address	Function code	Register address	Read words	Check sum
01	03	00 02	00 01	25 CA

Response frame of #1 machine is as below:

Appendix Table 2

Address	Function code	Register address	Read words	Check sum
01	03	02	13 88	B5 12

ASCII:

- 1) Frame header is "0x3A" while the default frame end is "0x0D" "0x0A"; also, frame end can be configured and defined by user;
- 2) In ASCII mode, all data bytes other than frame header and end are sent in the form of ASCII code; high-4-bit byte and low-4-bit byte are sent successively;
- 3) In ASCII mode, the data is 7-bit long. For 'A' - 'F', their uppercase ASCII codes are used;
- 4) Data is subjected to LRC check which covers the information portion from slave address to data;
- 5) Check sum is equal to the complement of sum of characters that participate in data check (abort the feed bit).

In ASCII mode, data frame format is as follows:

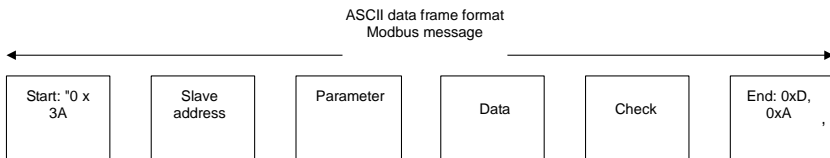

Examples of Modbus data frame in ASCII mode are as follows.

The writing of 4000 (0xFA0) into internal register 002 of #1 slave is shown in the table below.

$$\text{LRC check} = \text{complement of } (01+06+00+02+0x0F+0xA0) = 0x48$$

Appendix Table 3

Character	Header	Address		Parameter		Register address				Write-in content				LRC check		End	
	:	0	1	0	6	0	0	0	2	0	F	A	0	4	8	CR	LF
ASCII	3A	30	31	30	36	30	30	30	32	30	46	41	30	34	38	0D	0A

Different response delays can be set for drive through parameters so as to adapt to specific application requirements of various master stations; in RTU mode, the actual response delay is not less than 3.5 characters, while in ASCII mode, the actual response delay shall not be less than 1ms.

5. Protocol Function

The uppermost function of Modbus is to read and write parameters, and different parameters determine different operation requests. Parameters operations supported by inverter Modbus protocol are as shown in the table below:

Appendix Table 4 Parameters

Parameter	Meaning of parameter
0x03	Read drive functional parameters and running status parameters
0x06	Over-write individual drive functional parameters or control parameters, which are not saved on power loss
0x08	Line diagnosis
0x10	Over-write multiple drive functional parameters or control parameters, which are not saved on power loss
0x41	Write individual drive functional parameters or control parameters, and save them to non-volatile storage unit
0x42	Parameter management

Functional parameters, control parameters and status parameters of the drive are all mapped to read-write register of Modbus. Read-write characteristics and range of parameters comply with the instructions of user manual of the drive. Group numbers of drive parameters are mapped as high byte of register address, while in-group indexes are mapped as low byte of register address. Drive control parameters and status parameters are all virtualized as drive parameter groups. The corresponding relations between parameter group numbers and their high bytes of register address are as shown in table below:

Appendix Table 5 High-byte register addresses mapped from parameter group numbers

Parameter group	Mapping register address, high byte	Parameter group	Mapping register address, high byte
A0	0x00	E1	0x12
A1	0x01	F0	0x13
b0	0x02	F1	0x14
b1	0x03	F2	0x15
b2	0x04	F3	0x16
C0	0x05	F4	0x17
C1	0x06	F5	0x18
C2	0x07	F6	0x19

Parameter group	Mapping register address, high byte	Parameter group	Mapping register address, high byte
C3	0x08	H0	0x1A
C4	0x09	H1	0x1B
d0	0x0A	H2	0x1C
d1	0x0B	L0	0x1D
d2	0x0C	L1	0x1E
d3	0x0D	U0	0x1F
d4	0x0E	U1	0x20
d5	0x0F	U2	0x21
d6	0x10	Drive control parameter group	0x62
E0	0x11	Drive status parameter group	0x63

For example, the register address of drive parameter b0-02 is 0x202 while that of E0-07 is 0x1107.

In the following paragraphs, we present the formats and meanings of Modbus protocol parameters and data portion hereafter, i.e. to introduce the "parameter" and "data" related contents in above-noted data frame format. These two parts constitute the application layer protocol data unit of Modbus. The application layer protocol data unit mentioned below refers to these two parts. We take RTU mode for example to describe frame format below. The length of application layer protocol data unit should be doubled in ASCII mode.

Application layer protocol data units of various parameters are as follows:

Parameter 03: read register content

Request format is shown in appendix table 6.

Appendix Table 6

Application layer protocol data unit	Data length (number of bytes)	Range
Parameter	1	0x03
Register address	2	0x0000 - 0xFFFF
Number of registers	2	0x0001 - 0x004
Check	LRC or CRC	

Response format is shown in appendix table 7.

Appendix Table 7

Application layer protocol data unit	Data length (number of bytes)	Range
Parameter	1	0x03
Number of read bytes	1	2* number of registers
Register content	2* number of registers	
Check	LRC or CRC	

Parameter 06 (0x41): write register content (0x41 saved at power loss)

Request format is shown in appendix table 8.

Appendix Table 8

Application layer protocol data unit	Data length (number of bytes)	Range
Parameter	1	0x06
Register address	2	0x0000 - 0xFFFF
Register content	2	0x0000 - 0xFFFF
Check	LRC or CRC	

Response format is shown in appendix table 9.

Appendix Table 9

Application layer protocol data unit	Data length (number of bytes)	Range
Parameter	1	0x06
Register address	2	0x0000 - 0xFFFF
Register content	2	0x0000 - 0xFFFF
Check	LRC or CRC	

Some parameters of the drive are reserved and cannot be modified by communication setting. The list of these parameters is shown in appendix table 10.

Appendix Table 10

	Parameters	Remarks
(Parameter identification)	d0-24 d3-24	Communication not operable
(Parameter passing)	A0-05	Communication not operable
(User password)	A0-00	User password can not be set by communication, but the user password set by keypad can be unlocked by writing the same password from upper computer/device communication. Upper computer/device can view and modify parameters.

Parameter 08: communication line diagnosis.

Request format is shown in appendix table 11.

Appendix Table 11

Application layer protocol data unit	Data length (number of bytes)	Range
Parameter	1	0x08
Sub-parameter	2	0x0000 - 0x0030
Data	2	0x0000 - 0xFFFF
Check	LRC or CRC	

Response format is shown in appendix table 12.

Appendix Table 12

Application layer protocol data unit	Data length (number of bytes)	Range
Parameter	1	0x08
Sub-parameter	2	0x0000 - 0x0030
Data	2	0x0000 - 0xFFFF
Check	LRC or CRC	

Sub-parameters supported by line diagnosis are as set forth in the table below.

Appendix Table 13 Line diagnosis sub-parameter

Sub-PARA	Data (request)	Data (response)	Meaning of subfunction
0001	0000	0000	Reinitialize communication: make no-response mode disable.
	FF00	FF00	Reinitialize communication: make no-response mode disable.
0003	"New frame end" 00	"New frame end" 00	Set the frame end of ASCII mode and this "new frame end" will replace the original line feed symbol. (Note: new frame end shall not be greater than 0x7F and shall not be equal to 0x3A)
0004	0000	No response	Set no-response mode. Only response to reinitialization communication request. This is mainly used for isolating faulty equipment.
0030	0000	0000	Make slave no-response to invalid command and error command
	0001	0001	Make slave response to invalid command and error command

Parameter 0x10: write parameters continuously

Request format is shown in appendix table 14.

Appendix Table 14

Application layer protocol data unit	Data length (number of bytes)	Range
Parameter	1	0x10
Register address	2	0x0000 - 0xFFFF
Number of registers	2	0x1 - 0x4
Number of bytes of register content	1	2* number of operation registers
Register content	2* number of operation registers	
Check	LRC or CRC	

Response format is shown in appendix table 15.

Appendix Table 15

Application layer protocol data unit	Data length (number of bytes)	Range
Parameter	1	0x10
Register address	2	0x0000 - 0xFFFF
Number of registers	2	1 - 0x4
Check	LRC or CRC	

Parameter 0x42: parameter management

Request format is shown in appendix table 16.

Appendix Table 16

Application layer protocol data unit	Data length (number of bytes)	Range
Parameter	1	0x42
Sub-parameter	2	0x0000 - 0x0007
Data	2 (high byte is parameter group number, while low byte is parameter in-group index)	
Check	LRC or CRC	

Response format is shown in appendix table 17.

Appendix Table 17

Application layer protocol data unit	Data length (number of bytes)	Range
Parameter	1	0x42
Sub-parameter	2	0x0000 - 0x0007
Data	2	0x0000 - 0xFFFF
Check	LRC or CRC	

Sub-parameters supported by parameter management are set forth in the table 18.

Appendix Table 18 Parameter management sub-parameters

Sub-PARA	Data (request)	Data (response)	Meaning of subfunction
0x0000	Parameter group number and in-group index respectively possess high and low bytes	Upper limit of parameter	Read the upper limit of parameter
0x0001	Parameter group number and in-group index respectively possess high and low bytes	Lower limit of parameter	Read the lower limit of parameter
0x0002	Parameter group number and in-group index respectively possess high and low bytes	See specification below for details of parameter characteristics	Read the characteristics of parameter
0x0003	Parameter group number possesses high byte, while the lower byte is 0.	Maximum value of in-group index	Read the maximum value of in-group index
0x0004	Parameter group number possesses high byte, while the lower byte is 0.	The next parameter group number possesses high byte, while the lower byte is 0.	Read the next parameter group number
0x0005	Parameter group number possesses high byte, while the lower byte is 0.	The previous parameter group number possesses high byte, while the lower byte is 0.	Read the previous parameter group number

Status parameter group should not be modified and does not support the reading of upper and lower limits. Parameter characteristic is 2-byte long, and the bit definition is shown in the table below:

Appendix Table 19 Parameter characteristics

Characteristic parameter (BIT)	Value	Meaning
BIT1 - BIT0	00B	Changeable in running
	01B	Not changeable in running, but changeable in stop
	10B	Read only
	11B	Factory parameters

Characteristic parameter (BIT)	Value	Meaning
BIT4 - BIT3	000B	Accuracy: 1
	001B	Accuracy: 0.1
	010B	Accuracy: 0.01
	011B	Accuracy: 0.001
	100B	Accuracy: 0.0001
	Others	Reserved
BIT7 - BIT5	000B	The unit is A
	001B	The unit is Hz
	010B	The unit is Ω
	011B	The unit is r/min
	100B	The unit is S
	101B	The unit is V
	110B	The unit is %
	111B	No unit
BIT8	0: decimal; 1: hexadecimal	Display format
BIT9	0: non-quick menu; 1: quick menu	Quick menu or not
BIT10	0: not uploaded; 1: uploaded	Uploaded to keypad or not
BIT13 - BIT11	001B	Data width: 1
	010B	Data width: 2
	011B	Data width: 3
	100B	Data width: 4
	101B	Data width: 5
	110B	Data width: 6
	111B	Data width: 7
BIT14	Number of symbols available/not available	0: unsigned number; 1: directed number
BIT15	Reserved	Reserved

The response format is shown as table 20 when an error occurs.

Appendix Table 20

Application layer protocol data unit	Data length (number of bytes)	Range
Parameter	1	0x80 + parameter
Error code	1	
Check	LRC or CRC	

Error codes supported by Modbus protocol are listed in the table below:

Appendix Table 21 Error codes

Error codes	Meanings of error codes
0x1	Illegal parameter
0x2	Illegal register address
0x3	Data error, i.e. data are out of upper limit or lower limit
0x4	Slave operation failed, including errors caused by invalid data although there are in the range
0x5	Command is valid and being processed, mainly used for storing data to non-volatile storage
0x6	Slave is busy, please try again later; mainly used for storing data into non-volatile storage
0x18	Message frame error: including message length error and check error
0x20	Parameter is not changeable
0x21	Parameter is not changeable during the running
0x22	Parameter is under password protection

Drive control parameters are used for start, stop and running frequency setting. By detecting drive status parameters, running status and running mode can be obtained. Drive control parameters and status parameters are shown in appendix table 22.

Appendix Table 22 Control parameters

Register address	Parameter name	Save at power loss
0x6200	Control command word	No
0x6201	Master frequency command setting	Yes
0x6202	Auxiliary frequency command setting	Yes
0x6203	Master frequency command	No
0x6204	Auxiliary frequency command	No
0x6205	Multi-step frequency command	No
0x6206	Simple PLC frequency command	No
0x6207	PID digital setting percentage (0 - 100.0%)	No
0x6208	PID feedback percentage (0 - 100.0%)	No
0x6209	Electric driven torque limit (0 - 200.0%)	No
0x620A	Brake torque limit (0 - 200.0%)	No
0x620B	Reserved	No
0x620C	Reserved	No
0x620D	Reserved	No
0x620E	Analogue AO1 source setting	No
0x620F	Analogue EAO source setting	No
0x6210	Digital DO output source setting	No
0x6211	Setting of slave frequency setting proportion (0 - 100.0%)	No
0x6212	Virtual terminal communication setting	No
0x6213	Accel time 1	Yes
0x6214	Decel time 1	Yes

Appendix Table 23 Status parameters

Register address	Parameter name
0x6300	Running status word 1
0x6301	Current running frequency
0x6302	Output current
0x6303	Output voltage
0x6304	Output power
0x6305	Running rotation speed
0x6306	Bus voltage
0x6307	Output torque
0x6308	External counter
0x6309	High-bit words of actual length
0x630A	Low-bit words of actual length
0x630B	Status of digital input terminal
0x630C	Status of digital output terminal
0x630D	Setting of running frequency
0x630E	PID setting
0x630F	PID feedback
0x6310	Set length
0x6311	Set Accel time 1
0x6312	Set Decel time 1
0x6313	AI1 (unit: V)
0x6314	AI2 (unit: V)
0x6315	EAI (unit: V)
0x6316	DI (unit: kHz)
0x6317	The first running fault
0x6318	The second running fault
0x6319	The third (the latest) running fault
0x631A	Running display parameter
0x631B	Stop display parameter
0x631C	Setting of drive control pattern
0x631D	Frequency command pattern
0x631E	Master frequency command source
0x631F	Digital setting of master frequency command
0x6320	Auxiliary frequency command source

Register address	Parameter name
0x6321	Digital setting of auxiliary frequency command
0x6322	Drive status word 2
0x6323	Current fault of the drive

Drive control bits are defined as below table 24.

Appendix Table 24 Control bits

Control bit	Value	Meaning	Function description
BIT0	0	Run command disabled	Stop the drive
	1	Run command enabled	Start the drive
BIT1	1	Reverse	Set the running direction when run command enabled
	0	Forward	
BIT2	1	Jog	
	0	Jog disabled	
BIT3	1	Reset command enabled	
	0	Reset command disabled	
BIT4	1	Coast to stop enabled	
	0	Coast to stop disabled	
BIT15 - BIT5	000000B	Reserved	

& ATTENTION:

When BIT0 and BIT2 coexist, jog takes precedence.

Drive status bits are shown in appendix table 25.

Appendix Table 25 Status word 1 bits

Status bit	Value	Meaning	Remarks
BIT0	1	Running	
	0	Stop	
BIT1	1	Reversed	
	0	Forward	
BIT3 - BIT2	00B	Constant speed	
	01B	Accel	
	10B	Decel	
BIT4	0	Main setting not attained	
	1	Main setting attained	
BIT7 - BIT5	Reserved		
BIT15 - BIT8	00 - 0xFF	Fault code	0: drive normal. Non-0: drive at fault; Refer to relative specification of the meanings of the fault codes in this user manual

Appendix Table 26 Status word 2 bits

Status bit	Value	Meaning	Remarks
BIT0	1	Jog	
	0	Non-jog	
BIT1	1	PID running	
	0	Non-PID running	
BIT2	1	PLC running	
	0	Non-PLC running	
BIT3	1	Running at multi-step frequency	
	0	Running at non-multi step frequency	
BIT4	1	Ordinary running	
	0	Non-ordinary running	
BIT5	1	Wobble frequency	
	0	Non-wobble frequency	
BIT6	1	Undervoltage	
	0	Normal voltage	
BIT7	1	Sensor-less vector control	
	0	Non-sensor-less vector control	
BIT8	0	Reserved	
BIT9	0	Reserved	
BIT10	1	Parameter identification	
	0	Non-parameter identification	
Others	0	Reserved	

6. Operation Instructions

03H reads multiple (including one) registers (default address is 05):

Master enquiry:

Appendix Table 27

Address	Parameter	Register address	Number of registers	Check code
05	03	XX XX	000X	XX XX

Slave response:

Appendix Table 28

Address	Parameter	Total number of bytes	Data	Check code
05	03	2* number of registers	Bn - B0	XX XX

Register address: 0000 - 6322;

Number of registers: 00 01 - 00 04;

Data: n is equal to (2 x the number of registers -1).

Application example:

Note: before using communication controlling drive, please check if hardware is properly connected; in addition, be sure to properly set the communication data format, baud rate and address.

Parameter 03H is used here to read values of #5 slave's control parameters b0-00, b0-01, b0-02 and b0-03. At this moment, b0-00 = 0, b0-01 = 0, b0-02 = 50.00, b0-03 = 11.

Appendix Table 29

	Address	PARAM	Register address	Number of registers	Number of data bytes	Data	Check sum
Request	05	03	02 00	00 04	None	None	45 B1
Response	05	03	None	None	08	0x0000,0x0000, 0x1388, 0x000B	50 BE

Management of parameter 42H

Master enquiry:

Appendix Table 30

Address	Parameter	Sub-parameter	Data	Check code
05	42	XX XX	XX XX	XX XX

Slave response:

Appendix Table 31

Address	Parameter	Sub-parameter	Data	Check code
05	42	XX XX	B1 - B0	XX XX

Register address: 00 00 - 21 06 and 62 00 - 63 22.

Sub-parameter: refer to the table of parameter managing sub-parameter.

Data: refer to the values of data as set forth in the table of parameter managing sub-parameter.

Example:

Parameter 42H is used here to read the upper limit value of #5 slave's control parameter b0-02 which is 600.00:

Appendix Table 32

	Address	Parameter	Sub-PARA	Data	Check sum
Request	05	42	00 00	02 02	F8 E0
Response	05	42	00 00	EA 60	37 09

06 (41H data storage) writes that individual parameter data is not saved

Master enquiry:

Appendix Table 33

Address	Parameter	Register address	Data	Check code
05	06	62 00	B1 B0	XX XX

Slave response:

Appendix Table 34

Address	Parameter	Register address	Data	Check code
05	06	62 00	B1 B0	XX XX

Example:

Parameter 06H is used here to write #5 slave's control command (forward), i.e. to write 1 to register address 0x6200:

Appendix Table 35

	Address	Parameter	Register address	Number of registers	Number of data bytes	Data	Check sum
Request	05	06	62 00	None	None	00 01	56 36
Response	05	06	62 00	None	None	00 01	56 36

10H writes that the data of multiple registers are not saved

Master enquiry:

Appendix Table 36

Address	Parameter	Register address	Number of registers	Number of data bytes	Data	Check code
05	10	XX XX	0001 - 0004	Number of 2* registers	XX XX	XX XX

Slave response:

Appendix Table 37

Address	Parameter	Register address	Number of registers	Check code
05	10	XX XX	Number of 2* registers	XX XX

Register address: 00 00 - 1E 04, 62 00 - 62 14;

Number of registers: 00 01 - 00 04

Number of data bytes: 02 - 08

Data: n is equal to (2 x the number of registers -1).

Example:

Parameter 10H is used here to write the corresponding write data 1, 6 and 0 in control registers 0x6200, 0x6201 and 0x6202 of #5 slave:

Appendix Table 38

	Address	Parameter	Register address	Number of registers	Number of data bytes	Data	Check sum
Request	05	10	62 00	00 03	06	0001,0006,0000	C0 7C
Response	05	10	62 00	00 03	None	None	9E 34

08H: communication line diagnosis

Master enquiry:

Appendix Table 39

Address	Parameter	Sub-parameter	Data	Check code
05	08	XX XX	XX XX	XX XX

Slave response:

Appendix Table 40

Address	Function code	Subfunction code	Data	Check code
05	08	XX XX	Bn - B0	XX XX

Sub-parameter: table of line diagnosis sub-parameter

Example:

Parameter 08H is used here to set the communication no-response mode of #5 slave:

Appendix Table 41

	Address	Parameter	Sub-PARA	Data	Check sum
Request	05	08	00 04	00 00	A0 4E
Response	05	08	00 04	00 00	A0 4E

Read error or warning

In case illegal parameter, illegal register address, data errors and other anomalies are detected during communication, slave response communication anomaly will occur. In such a case, the slave response will be in the following formats:

Slave response:

Appendix Table 42

Address	Parameter	Data	Check code
05	0x80+parameter	Error code	XX XX

Example:

Parameter 10H is used here to write the corresponding write data 1, 11, 4 and 100.00 in control registers 0x6200, 0x6201, 0x6202 and 0x6203 of #5 slave:

Appendix Table 43

	Address	Parameter	Register address	Number of registers	Number of data bytes	Data	Check sum
Request	5	10	62 00	00 04	08	0001,000B 0004 2710	DA 67
Response	5	90	None	None	None	20	0C 19

7. LRC/CRC Generation

In consideration of the demand for speed improvement, CRC-16 is usually realized in form mode. C-language source codes for realization of CRC-16 are given below. Please note that the high and low bytes have been exchanged in final result, that is to say, the result is the CRC check sum to be sent:

```

/* The function of CRC16*/
Uint16 CRC16(const Uint16 *data, Uint16 len)
{
    Uint16 crcValue = 0xffff;
    Uint16 i;
    while (len--)
    {
        crcValue ^= *data++;
        for (i = 0; i <= 7; i++)
        {
            if (crcValue & 0x0001)
            {
                crcValue = (crcValue >> 1) ^ 0xa001;
            }
            else
            {
                crcValue = crcValue >> 1;
            }
        }
    }
    return (crcValue);
}

/* The table of CRC16*/
const unsigned short crc16_ccitt_table[256] ={
    0x0000,0xc0c1,0xc181,0x0140,0xc301,0x03c0,0x0280,0xc241,0xc601,0x06c0,
    0x0780,0xc741,0x0500,0xc5c1,0xc481,0x0440,0xcc01,0x0cc0,0x0d80,0xcd41,0x0f00,
    0xcfc1,0xce81,0x0e40,0x0a00,0xcac1,0xcb81,0x0b40,0xc901,0x09c0,0x0880,0xc841,
    0xd801,0x18c0,0x1980,0xd941,0x1b00,0xdbc1,0xda81,0x1a40,0x1e00,0xdec1,0xdf81,
    0x1f40,0xdd01,0x1dc0,0x1c80,0xdc41,0x1400,0xd4c1,0xd581,0x1540,0xd701,0x17c0,
    0x1680,0xd641,0xd201,0x12c0,0x1380,0xd341,0x1100,0xd1c1,0xd081,0x1040,0xf001,
    0x30c0,0x3180,0xf141,0x3300,0xf3c1,0xf281,0x3240,0x3600,0xf6c1,0xf781,0x3740,
    0xf501,0x35c0,0x3480,0xf441,0x3c00,0xfc1,0xfd81,0x3d40,0xff01,0x3fc0,0x3e80,
    0xfe41,0xfAO1,0x3ac0,0x3b80,0xfb41,0x3900,0xf9c1,0xf881,0x3840,0x2800,0xe8c1,
    0xe981,0x2940,0xeb01,0x2bc0,0x2a80,0xea41,0xee01,0x2ec0,0x2f80,0xef41,0x2d00,

```

0xedc1,0xec81,0x2c40,0xe401,0x24c0,0x2580,0xe541,0x2700,0xe7c1,0xe681,0x2640,
0x2200,0xe2c1,0xe381,0x2340,0xe101,0x21c0,0x2080,0xe041,0xa001,0x60c0,0x6180,
0xa141,0x6300,0xa3c1,0xa281,0x6240,0x6600,0xa6c1,0xa781,0x6740,0xa501,0x65c0,
0x6480,0xa441,0x6c00,0xacc1,0xad81,0x6d40,0xaf01,0x6fc0,0x6e80,0xae41,0xA01,
0x6ac0,0x6b80,0xab41,0x6900,0xa9c1,0xa881,0x6840,0x7800,0xb8c1,0xb981,0x7940,
0xbb01,0x7bc0,0x7a80,0xba41,0xbe01,0x7ec0,0x7f80,0xbf41,0x7d00,0xbdc1,0xbc81,
0x7c40,0xb401,0x74c0,0x7580,0xb541,0x7700,0xb7c1,0xb681,0x7640,0x7200,0xb2c1,
0xb381,0x7340,0xb101,0x71c0,0x7080,0xb041,0x5000,0x90c1,0x9181,0x5140,0x9301,
0x53c0,0x5280,0x9241,0x9601,0x56c0,0x5780,0x9741,0x5500,0x95c1,0x9481,0x5440,
0x9c01,0x5cc0,0x5d80,0x9d41,0x5f00,0x9fc1,0x9e81,0x5e40,0x5a00,0x9ac1,0x9b81,
0x5b40,0x9901,0x59c0,0x5880,0x9841,0x8801,0x48c0,0x4980,0x8941,0x4b00,0x8bc1,
0x8a81,0x4a40,0x4e00,0x8ec1,0x8f81,0x4f40,0x8d01,0x4dc0,0x4c80,0x8c41,0x4400,
0x84c1,0x8581,0x4540,0x8701,0x47c0,0x4680,0x8641,0x8201,0x42c0,0x4380,0x8341,
0x4100,0x81c1,0x8081,0x4040

};

CG Drives & Automation

www.cgglobal.com / www.emotron.com